

## ***RS-232, RS-422, RS485 Multiprotocol Transceivers with Internal 120Ω Termination and Wide Output Swing***

UM3011 QFN24 4.0×4.0

### **1 Description**

The UM3011 is highly integrated, robust and advanced multiprotocol transceiver supporting RS-232, RS-422 and RS-485 serial standards. The device offers one transmitter and one receiver in RS-232 mode. The device also integrates one transmitter and one receiver to support half and full duplex RS-485 communication. MODE selection pins enable shared bus and logic pins for the protocols to share a common single connector. Integrated termination resistance for RS-485 bus pins and for RS-232 receiver inputs need no external components to realize a fully-functional and switchable communication port.

The UM3011 operates up to 20Mbps in RS-485/RS-422 modes, and up to 1Mbps in RS-232 mode. What's more, based on the SLR pin setting, the UM3011 can be limited to 0.5Mbps low-speed RS-485 mode and 0.25Mbps low-speed RS-232 mode.

The device features integrated robust IEC ESD protection. What's more, the RS-485 receiver fail-safe feature drives logic high on received logic output when the bus inputs are open or shorted together or when the bus is idle.

The UM3011 needs 3.0V to 5.5V supply that fully powers four external charge pump capacitors for RS-232 and the driver/receiver for both RS-232 and RS-485. The device is also configured with 1.65V to 5.5V logic supply for logic data and control signals. Additionally, the device also features nSHDN pin to achieve extremely low current consumption when the system disables the device.

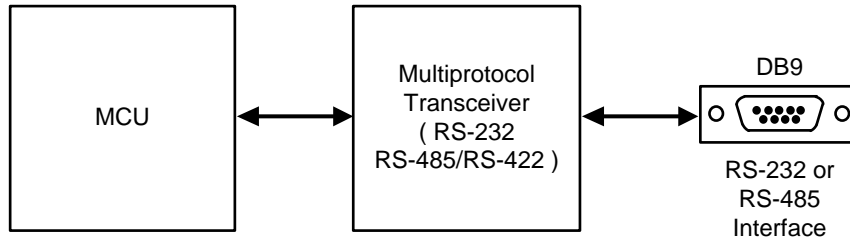
### **2 Features**

- Meets or exceeds the requirements of the TIA/EIA-485A and TIA/EIA-232F standards
- 1 transmitter, 1 receiver for RS-232
- 1 transmitter, 1 receiver for RS-485
- Integrated switchable 120Ω termination resistor for half and full duplex RS-485 mode
- Integrated charge-pump for RS-232
- Large output swing (typical ±8.5V) for RS-232 mode with V<sub>CC</sub> = 5V supply
- Open, short, and idle bus failsafe for RS-485 receiver
- Space-saving QFN24 4.0×4.0 package
- 3V to 5.5V supply voltage
- 1.65V to 5.5V supply voltage for logic pins
- RS-485 differential output exceeds 2.1V for PROFIBUS compatibility with 5V supply
- Selectable Data Rates with SLR Pin:
  - RS-232 mode: 250kbps and 1Mbps
  - RS-485 half-duplex and full-duplex mode: 500kbps and 20Mbps
- Glitch-free power-up/down for hot plug-in capability
- Bus short-circuit protection, thermal Shutdown
- Extended ambient temperature range: -40°C to 125°C

### **3 Applications**

- Industrial
- HVAC Systems
- Point-of-sale terminals
- Factory automation and control
- Building automation
- Grid infrastructure

## 4 Simplified Schematic



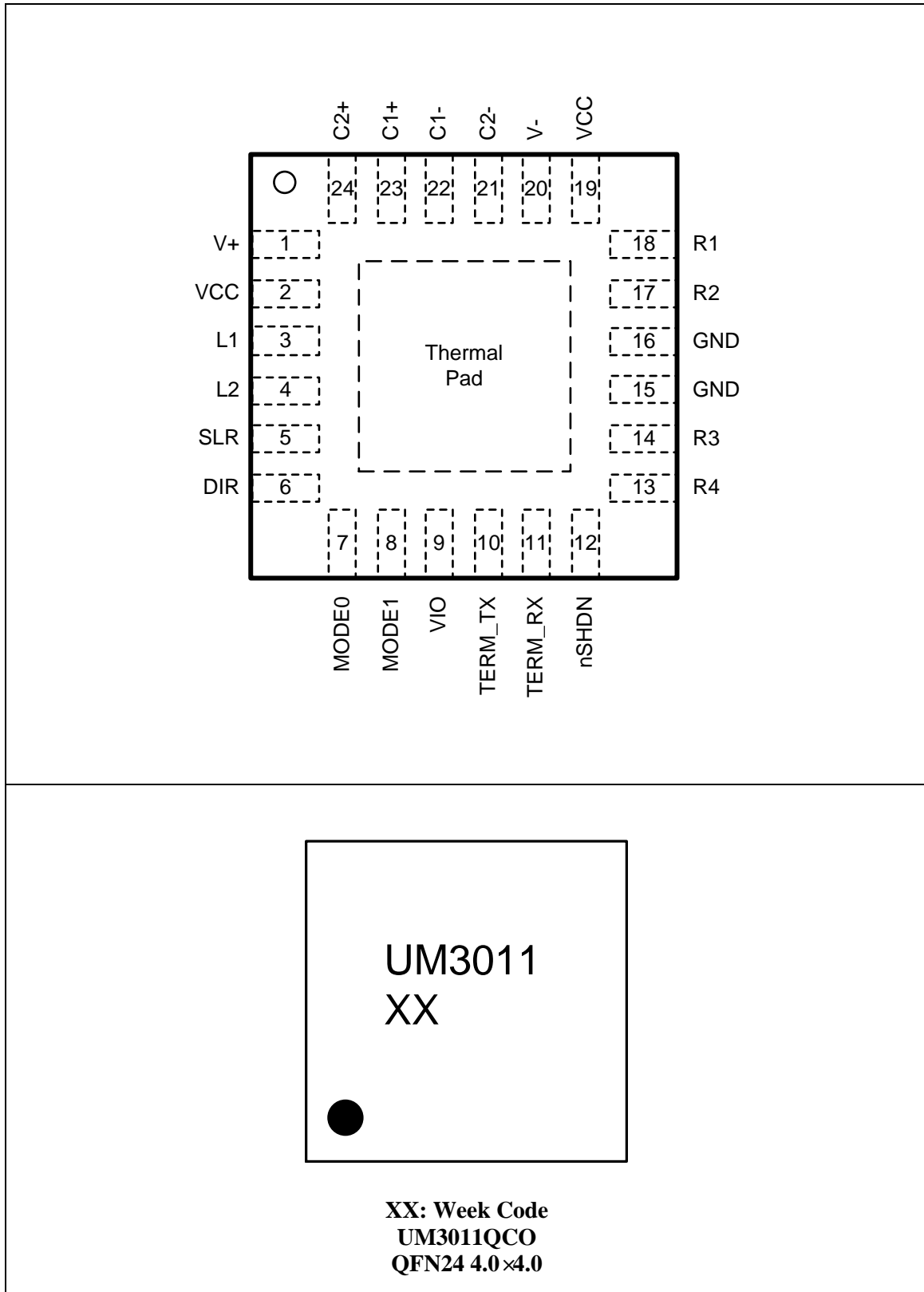
## 5 Selection Guide

Part Number	V <sub>CC</sub> Supply (V)	V <sub>IO</sub> Supply (V)	RS-232 Transceivers Number	RS-485 Transceivers Number	RS-232 Transceivers Data Rate (Mbps)	RS-485 Transceivers Data Rate (Mbps)
UM3011QCO	3 to 5.5	1.65 to 5.5	1T / 1R	1T / 1R	0.25 / 1	0.5 / 20

## 6 Ordering Information

Part Number	Mark Code	Package Type	Shipping Qty
UM3011QCO	UM3011	QFN24 4.0×4.0	3000pcs/13Inch Tape & Reel

## 7 Pin Configuration and Function



**7 Pin Configuration and Function (continued)**

Table 7-1. Pin Functions of UM3011

Pin No.	Pin Name	Function
1	V+	Positive charge pump rail.
2	VCC	3V to 5.5V supply voltage. (Note 1)
3	L1	Logic output (RS-232/RS-485).
4	L2	Logic input (RS-232/RS-485). Integrated weak pull-up resistor.
5	SLR	Slew rate control, internal pull-down resistor. SLR=H enables slow speed.
6	DIR	RS-485 TX/RX enable/disable. Internal pull-down resistor.
7	MODE0	MODE control pin 0, Integrated weak pull-down resistor.
8	MODE1	MODE control pin 1, Integrated weak pull-down resistor.
9	VIO	1.65V to 5.5V logic supply voltage.
10	TERM_TX	120 $\Omega$ Termination resistance enable/disable between R1 and R2. Internal Pull down resistor.
11	TERM_RX	120 $\Omega$ Termination resistance enable/disable between R3 and R4. Internal Pull down resistor.
12	nSHDN	Device enable/disable. Internal pull-down resistor.
13	R4	RS-485 inverting receiver input (B).
14	R3	RS-232 driver output or RS-485 non-inverting receiver input (A).
15, 16	GND	Ground. (Note 2)
17	R2	RS-232 receiver input or RS-485 bus pin (Y or A).
18	R1	RS-485 bus pin (Z or B).
19	VCC	3V to 5.5V supply voltage. (Note 1)
20	V-	Negative charge pump rail.
21	C2-	Negative terminal of charge pump capacitor.
22	C1-	Negative terminal of charge pump capacitor.
23	C1+	Positive terminal of charge pump capacitor.
24	C2+	Positive terminal of charge pump capacitor.

Note 1: All V<sub>CC</sub> pins must be powered by a common supply on PCB.

Note 2: All GND pins must be grounded on PCB.

## 8 Specifications

### 8.1 Absolute Maximum Ratings (Note 1)

Symbol	Parameter	Conditions	Min	Max	Unit
V <sub>CC</sub>	Bus supply voltage	V <sub>CC</sub> to GND	-0.5	6.0	V
V <sub>IO</sub>	Logic supply voltage	V <sub>IO</sub> to GND	-0.5	6.0	V
V <sub>+</sub>	Charge pump positive-output supply voltage	V <sub>+</sub> to GND	-0.3	14	V
V <sub>-</sub>	Charge pump negative-output supply voltage	V <sub>-</sub> to GND	-14	0.3	V
V <sub>BUS</sub>	Bus voltage at any bus pin	R1, R2, R3, R4 with respect to GND	-16	16	V
V <sub>ID</sub>	Differential bus voltage	(R1-R2) or (R2-R1), (R3-R4) or (R4-R3) with termination disabled	-22	22	V
	Differential bus voltage at RS485 mode	(R1-R2) or (R2-R1), (R3-R4) or (R4-R3) with termination enabled	-6	6	V
V <sub>I</sub>	Input voltage at any logic pin	L2, SLR, nSHDN, TERM_TX, TERM_RX, MODE0, MODE1, DIR DIR pins	-0.3	V <sub>IO</sub> +0.2	V
V <sub>ESD</sub>	Human-body model (HBM), per ANSI/ESDA/JEDEC JS-001	Bus terminals (R1, R2, R3, R4, R5, R6, R7, R8) and GND	-8	8	kV
I <sub>O</sub>	Receiver output current	L1 pin	-8	8	mA
T <sub>STG</sub>	Storage temperature		-65	150	°C
T <sub>J</sub>	Junction temperature		-40	170	°C
T <sub>L</sub>	Lead Temperature for Soldering 10 Seconds			260	°C

Note 1: Stresses beyond those listed under Absolute Maximum Ratings may cause permanent damage to the device. These are stress ratings only, which do not imply functional operation of the device at these or any other conditions beyond those indicated under Recommended Operating Conditions. Exposure to absolute-maximum-rated conditions for extended periods may affect device reliability.

**8.2 Recommended Operating Conditions**

Symbol	Parameter	Conditions	Min	Typ	Max	Unit
V <sub>CC</sub>	Bus supply voltage		3		5.5	V
V <sub>IO</sub>	Logic supply voltage		1.65		5.5	V
V <sub>I(RS-485)</sub>	Input voltage at any bus terminal in RS-485 mode	R1, R2, R3, R4 pins	-7		12	V
V <sub>ID</sub>	Differential input voltage in RS-485 receive mode [ (R1-R2) or (R2-R1), (R3-R4) or (R4-R3) ] with on-chip termination resistor disabled		-12		12	V
V <sub>I(RS-232)</sub>	Receiver input voltage in RS-232 mode	R2 pin	-15		15	V
V <sub>IH</sub>	High-level input voltage	L2, SLR, nSHDN, TERM_TX, TERM_RX, MODE0, MODE1, DIR pins	0.7V <sub>IO</sub>		V <sub>IO</sub>	V
V <sub>IL</sub>	Low-level input voltage		0		0.3V <sub>IO</sub>	V
I <sub>O</sub>	Output current, driver in RS-485 mode		-60		60	mA
I <sub>OR</sub>	Output current, receiver in RS-485 mode	V <sub>IO</sub> = 1.8V or 2.5V	-2		2	mA
		V <sub>IO</sub> = 3.3V or 5V	-4		4	mA
R <sub>L</sub>	Differential load resistance in RS-485 mode		54	60		Ω
1/ t <sub>UI</sub>	Signaling rate in RS-485 mode	SLR = V <sub>IO</sub>			500	kbps
		SLR = GND or floating			20	Mbps
	Signaling rate in RS-232 mode	SLR = V <sub>IO</sub>			250	kbps
		SLR = GND or floating			1	Mbps
T <sub>A</sub>	Operating ambient temperature	Note 1	-40		125	°C

Note 1: Operation is specified for internal (junction) temperatures up to 150°C. Self-heating due to internal power dissipation should be considered for each application. Maximum junction temperature is internally limited by the thermal shutdown (T<sub>SD</sub>) circuit which disables the driver and receiver when the junction temperature reaches 170°C.

**8.3 Thermal Information**

Symbol	Parameter		Value	Unit
R <sub>θJA</sub>	Junction to ambient thermal resistance	QFN24 4.0×4.0	32.3	°C/W

**8.4 Power Dissipation**

Symbol	Parameter	Conditions	Min	Typ	Max	Unit
P <sub>D(RS-485)</sub>	Driver outputs externally shorted to receiver inputs, DIR = V <sub>IO</sub> , MODE1, MODE0 = 11; V <sub>CC</sub> = V <sub>IO</sub> = 5.5 V, T <sub>A</sub> = 125 °C, L2 = square wave 50% duty	Unterminated, TERM_TX = L, TERM_RX = L, SLR = H (500kbps)		185	300	mW
		Unterminated, TERM_TX = L, TERM_RX = L, SLR = L (20Mbps)		170	350	
		TERM_TX = V <sub>IO</sub> , TERM_RX = V <sub>IO</sub> , SLR = H (500kbps)		450	500	mW
		TERM_TX = V <sub>IO</sub> , TERM_RX = V <sub>IO</sub> , SLR = L (20Mbps)		370	575	
P <sub>D(RS-232)</sub>	RS-232 mode with MODE1, MODE0 = 01	V <sub>CC</sub> = V <sub>IO</sub> = 5.5V, R3 bus line loaded with 3 kΩ, R3 load cap = 1000 pF, L2 toggling, SLR = L (1Mbps)		340	500	mW
		V <sub>CC</sub> = V <sub>IO</sub> = 5.5V, R3 bus line loaded with 3 kΩ, R3 load cap = 1000 pF, L2 toggling, SLR = H (250kbps)		250	350	

**8.5 Electrical Characteristics(Static)**

$V_{CC} = 3V$  to  $5.5V$ ,  $V_{IO} = 1.65V$  to  $5.5V$ ,  $T_A = -40\text{ }^{\circ}\text{C}$  to  $125\text{ }^{\circ}\text{C}$ , unless otherwise noted. All typical values are at  $25\text{ }^{\circ}\text{C}$  and supply voltage of  $V_{CC} = 5V$ ,  $V_{IO} = 3.3V$ .

Symbol	Parameter	Conditions	Min	Typ	Max	Unit
<b>Supply</b>						
$V_{UVD(RIS)VCC}$	Rising under-voltage threshold on VCC			2.5	2.8	V
$V_{UVD(FAL)VCC}$	Falling under-voltage threshold on VCC		1.9	2.3		V
$V_{UVD(HYS)VCC}$	Hysteresis on under-voltage of VCC		100	200		mV
$V_{UVD(RIS)VIO}$	Rising under-voltage threshold on VIO			1.2	1.6	V
$V_{UVD(FAL)VIO}$	Falling under-voltage threshold on VIO		0.8	1.1		V
$V_{UVD(HYS)VIO}$	Hysteresis on under-voltage of VIO			100		mV
$I_{CC(SHDN)}$	Supply current in shutdown mode	$V_{CC} = 4.5V$ to $5.5V$ , nSHDN = GND, All other logic input pins floating, no load on bus, $T_A \leq 125\text{ }^{\circ}\text{C}$		0.5	15	$\mu\text{A}$
		$V_{CC} = 3V$ to $3.6V$ , nSHDN = GND, All other logic input pins floating, no load on bus, $T_A \leq 125\text{ }^{\circ}\text{C}$		0.3	12	$\mu\text{A}$
		$V_{CC} = 4.5V$ to $5.5V$ , nSHDN = GND, All other logic input pins floating, no load on bus, $T_A \leq 105\text{ }^{\circ}\text{C}$		0.5	12	$\mu\text{A}$
		$V_{CC} = 3V$ to $3.6V$ , nSHDN = GND, All other logic input pins floating, no load on bus, $T_A \leq 105\text{ }^{\circ}\text{C}$		0.3	10	$\mu\text{A}$
$I_{IO(SHDN)}$	Logic supply current in shutdown mode	$V_{IO} = 1.65V$ to $5.5V$ , nSHDN = GND, All other logic input pins floating			2	$\mu\text{A}$

**8.5 Electrical Characteristics(Static) (continued)**

$V_{CC} = 3V$  to  $5.5V$ ,  $V_{IO} = 1.65V$  to  $5.5V$ ,  $T_A = -40^\circ C$  to  $125^\circ C$ , unless otherwise noted. All typical values are at  $25^\circ C$  and supply voltage of  $V_{CC} = 5V$ ,  $V_{IO} = 3.3V$ .

Symbol	Parameter	Conditions	Min	Typ	Max	Unit
$I_{CC(485)}$	Supply current (quiescent), $V_{CC} = 4.5V$ to $5.5V$ , $TERM\_TX$ , $TERM\_RX =$ Floating or low, $SLR = X$	Driver and receiver enabled, $DIR = V_{IO}$ , $MODE1$ , $MODE0 = 11$ (Full duplex), No load		1.9	3.4	mA
		Driver enabled, receiver disabled, $DIR = V_{IO}$ , $MODE1$ , $MODE0 = 10$ (Half duplex), No load		1.9	2.8	mA
		Driver disabled, receiver enabled, $DIR = GND$ , $MODE1$ , $MODE0 = 10$ (Half duplex), No load		1.55	2.5	mA
	Supply current (quiescent), $V_{CC} = 3V$ to $3.6V$ , $TERM\_TX$ , $TERM\_RX =$ Floating or low, $SLR = X$	Driver and receiver enabled, $DIR = V_{IO}$ , $MODE1$ , $MODE0 = 11$ (Full duplex), No load		1.7	2.8	mA
		Driver enabled, receiver disabled, $DIR = V_{IO}$ , $MODE1$ , $MODE0 = 10$ (Half duplex), No load		1.7	2.3	mA
		Driver disabled, receiver enabled, $DIR = GND$ , $MODE1$ , $MODE0 = 10$ (Half duplex), No load		1.3	2.1	mA
$I_{IO(485)}$	Logic supply current (quiescent), $V_{IO} = 3V$ to $3.6V$ , $TERM\_TX$ , $TERM\_RX =$ Floating	Driver disabled, receiver enabled, $SLR = GND$ , $DIR = GND$ , $MODE1$ , $MODE0 = 10$ (Half duplex), No load		9	17	$\mu A$
		Driver disabled, receiver enabled, $SLR = V_{IO}$ , $DIR = GND$ , $MODE1$ , $MODE0 = 10$ (Half duplex), No load		10.5	21	$\mu A$
$I_{CC(485)DT}$	Supply current in RS-485 driver termination mode	Driver enabled with termination ON; $MODE1$ , $MODE0 = 11$ (full duplex), $DIR = V_{IO}$ , $TERM\_TX = V_{IO}$		38	50	mA
$I_{CC(485)RT}$	Supply current in RS-485 receiver termination mode	Receiver enabled with termination ON; $MODE1$ , $MODE0 = 11$ (full duplex), $DIR = GND$ , $TERM\_RX = V_{IO}$		2.5	3.8	mA
$I_{CC(232)}$	Supply current in RS-232 mode	$MODE1$ , $MODE0 = 01$ , $nSHDN = V_{IO}$ ; other logic inputs floating, No load		4.5	9.3	mA

**8.5 Electrical Characteristics(Static) (continued)**

$V_{CC} = 3V$  to  $5.5V$ ,  $V_{IO} = 1.65V$  to  $5.5V$ ,  $T_A = -40^\circ C$  to  $125^\circ C$ , unless otherwise noted. All typical values are at  $25^\circ C$  and supply voltage of  $V_{CC} = 5V$ ,  $V_{IO} = 3.3V$ .

Symbol	Parameter	Conditions	Min	Typ	Max	Unit
<b>Integrate termination resistor in RS-485 mode</b>						
$R_{TERM(TX)}$	120 $\Omega$ termination across driver output R1/R2 terminals	MODE1, MODE0 = 11 (Full duplex) or 10 (half duplex); DIR=GND, TERM_TX = $V_{IO}$ , $V_{R2R1} = 2V$ , $V_{R1} = -7V, 0V, 10V$ , See Figure 9-9	102	120	138	$\Omega$
$R_{TERM(RX)}$	120 $\Omega$ termination across receiver output R3/R4 terminals	MODE1, MODE0 = 11 (Full duplex); TERM_RX = $V_{IO}$ , $V_{R3R4} = 2V$ , $V_{R4} = -7V, 0V, 10V$ , See Figure 9-9	102	120	138	$\Omega$
<b>Logic</b>						
$I_{IN}$	Input current	$1.65V \leq V_{IO} \leq 5.5V$ , $0V \leq V_{IN} \leq V_{IO}$ , (L2, DIR, nSHDN, SLR, TERM_TX, TERM_RX, MODE1, MODE0)	-20		8	$\mu A$
$V_{IH}$	Input High Voltage	$1.65V \leq V_{IO} \leq 5.5V$			$0.7V_{IO}$	V
$V_{IL}$	Input low Voltage		$0.3V_{IO}$			V
<b>RS-485 Driver</b>						
$ V_{OD} $	Driver differential output voltage magnitude	$R_L = 60\Omega$ , $-7V \leq V_{TEST} \leq 12V$ , See Figure 9-1	1.5	3.4		V
		$R_L = 60\Omega$ , $-7V \leq V_{TEST} \leq 12V$ , $4.5V \leq V_{CC} \leq 5.5V$ See Figure 9-1	2.1	3.4		V
		$R_L = 100\Omega$ , See Figure 9-2	2	3.9		V
		$R_L = 54\Omega$ , $4.5V \leq V_{CC} \leq 5.5V$ See Figure 9-2	2.1	3.4		V
		$R_L = 54\Omega$ , See Figure 9-2	1.5	3.4		V
$\Delta  V_{OD} $	Change in magnitude of driver differential output voltage	$R_L = 54\Omega$ or $100\Omega$ See Figure 9-2	-50		50	mV
$V_{OC}$	Common-mode output voltage	$R_L = 54\Omega$ or $100\Omega$ See Figure 9-2		$V_{CC}/2$	3	V
$\Delta V_{OC(SS)}$	Change in steady-state common-mode output voltage	$R_L = 54\Omega$ or $100\Omega$ See Figure 9-2	-50		50	mV

**8.5 Electrical Characteristics(Static) (continued)**

$V_{CC} = 3V$  to  $5.5V$ ,  $V_{IO} = 1.65V$  to  $5.5V$ ,  $T_A = -40^\circ C$  to  $125^\circ C$ , unless otherwise noted. All typical values are at  $25^\circ C$  and supply voltage of  $V_{CC} = 5V$ ,  $V_{IO} = 3.3V$ .

Symbol	Parameter	Conditions	Min	Typ	Max	Unit
$I_{OS}$	Short-circuit output current (Note 2)	$DIR = V_{IO}$ , $-7V \leq (V_{R2}$ or $V_{R1}) \leq 12V$ , or R1 shorted to R2	-250		250	mA
$I_{OZD}$	Driver High impedance output leakage current on R1 and R2 in Full duplex mode	MODE1, MODE0 = 11, TERM_TX = GND, DIR = GND, $V_{CC} = GND$ or $5.5V$ , $V_O = -7V, +12V$	-125		125	$\mu A$
		MODE1, MODE0 = 11, TERM_TX = $V_{IO}$ , DIR = GND, $V_{CC} = 5.5V$ , $V_O = -7V, +12V$	-325		350	$\mu A$
<b>RS-485 Receiver</b>						
$I_I$	Bus input current (termination disabled)	Half and full duplex modes, DIR = GND, $V_{CC} = V_{IO} = 0V$ or $5.5V$ , $V_I = 12V$		75	125	$\mu A$
		Half and full duplex modes, DIR = GND, $V_{CC} = 0V$ or $5.5V$ , $V_I = -7V$	-450	-50		$\mu A$
$I_{RXT}$	Receiver bus input leakage current with termination enabled	Full duplex mode, $V_{CC} = V_{IO} = 5.5V$ , TERM_RX = $V_{CC}$ , $V_I = -7$ to $12V$	-450		325	$\mu A$
$V_{TH+}$	Positive-going input threshold voltage (Note 1)	Over common-mode range of $-7V$ to $12V$		100	200	mV
$V_{TH-}$	Negative-going input threshold voltage (Note 1)		-200	-100		mV
$V_{HYS}$	Input hysteresis			200		mV
$C_{A,B}$	Input differential capacitance	Measured between R3 and R4, $f = 1MHz$		45		pF
$V_{OH}$	Output high voltage L1 pin	$I_{OH} = -4mA$ , $V_{IO} = 3V$ to $3.6V$ or $4.5V$ to $5.5V$	$V_{IO} - 0.4$	$V_{IO} - 0.2$		V
$V_{OL}$	Output low voltage L1 pin	$I_{OL} = 4mA$ , $V_{IO} = 3V$ to $3.6V$ or $4.5V$ to $5.5V$		$V_{IO} - 0.2$	0.4	V
$V_{OH}$	Output high voltage L1 pin	$I_{OH} = -2mA$ , $V_{IO} = 1.65V$ to $1.95V$ or $2.25V$ to $2.75V$	$V_{IO} - 0.4$	0.2		V
$V_{OL}$	Output low voltage L1 pin	$I_{OH} = 2mA$ , $V_{IO} = 1.65V$ to $1.95V$ or $2.25V$ to $2.75V$		0.2	0.4	V
$I_{OZ}$	Output high-impedance current, L1 pin	$V_O = 0V$ or $V_{IO}$ , DIR = $V_{IO}$ , MODE1, MODE0 = 10 (half duplex mode)	-1		1	$\mu A$

**8.5 Electrical Characteristics(Static) (continued)**

$V_{CC} = 3V$  to  $5.5V$ ,  $V_{IO} = 1.65V$  to  $5.5V$ ,  $T_A = -40\text{ }^\circ\text{C}$  to  $125\text{ }^\circ\text{C}$ , unless otherwise noted. All typical values are at  $25\text{ }^\circ\text{C}$  and supply voltage of  $V_{CC} = 5V$ ,  $V_{IO} = 3.3V$ .

Symbol	Parameter	Conditions	Min	Typ	Max	Unit
<b>RS-232 Driver</b>						
$V_{OH}$	High-level output voltage	DOUT (R3) at $R_L = 3\text{ k}\Omega$ to GND, DIN (L2) = GND; $V_{CC} = 3V$ to $3.6V$	4.2	5.5	7	V
		DOUT (R3) at $R_L = 3\text{ k}\Omega$ to GND, DIN (L2) = GND; $V_{CC} = 4.5V$ to $5.5V$	6.3	8.5	10	V
$V_{OL}$	Low-level output voltage	DOUT (R3) at $R_L = 3\text{ k}\Omega$ to GND, DIN (L2) = $V_{IO}$ ; $V_{CC} = 3V$ to $3.6V$	-7	-5.5	-4.2	V
		DOUT (R3) at $R_L = 3\text{ k}\Omega$ to GND, DIN (L2) = $V_{IO}$ ; $V_{CC} = 4.5V$ to $5.5V$	-10	-8.5	-6.3	V
$I_{OS}$	Short-circuit output current (Note 2)	$V_{CC} = 3.6V$ , $V_O = 0V$		$\pm 35$	$\pm 60$	mA
		$V_{CC} = 5.5V$ , $V_O = 0V$		$\pm 35$	$\pm 60$	mA
$I_{OFF}$	Output leakage current on R3 pin	nSHDN = GND, $V_{CC} = 3V$ to $3.6V$ , $V_O = \pm 12V$	-125		125	$\mu\text{A}$
		nSHDN = GND, $V_{CC} = 4.5V$ to $5.5V$ , $V_O = \pm 10V$	-125		125	$\mu\text{A}$
<b>RS-232 Receiver</b>						
$V_{OH}$	High-level output voltage on L1 pin	$I_{OH} = -1.5\text{ mA}$ , $V_{IO} = 3V$ to $3.6V$ or $4.5V$ to $5.5V$	$V_{IO}-0.5$			V
		$I_{OH} = -1\text{ mA}$ , $V_{IO} = 1.65V$ to $1.95V$ or $2.25V$ to $2.75V$	$V_{IO}-0.5$			V
$V_{OL}$	Low-level output voltage on L1 pin	$I_{OL} = 2\text{ mA}$ , $V_{IO} = 3V$ to $3.6V$ or $4.5V$ to $5.5V$			0.4	V
		$I_{OL} = 1\text{ mA}$ , $V_{IO} = 1.65V$ to $1.95V$ or $2.25V$ to $2.75V$			0.4	V

**8.5 Electrical Characteristics(Static) (continued)**

$V_{CC} = 3V$  to  $5.5V$ ,  $V_{IO} = 1.65V$  to  $5.5V$ ,  $T_A = -40\text{ }^{\circ}\text{C}$  to  $125\text{ }^{\circ}\text{C}$ , unless otherwise noted. All typical values are at  $25\text{ }^{\circ}\text{C}$  and supply voltage of  $V_{CC} = 5V$ ,  $V_{IO} = 3.3V$ .

Symbol	Parameter	Conditions	Min	Typ	Max	Unit
$V_{TH+}$	Positive-going input threshold voltage on RS-232 receiver input (R2) (Note 1)	$V_{CC} = 3.3V$		1.4	2.4	V
		$V_{CC} = 5V$		2	2.4	V
$V_{TH-}$	Negative-going input threshold voltage on RS-232 receiver input (R2) (Note 1)	$V_{CC} = 3.3V$	0.6	1.1		V
		$V_{CC} = 5V$	0.8	1.6		V
$V_{HYS}$	Input hysteresis on receiver inputs ( $V_{TH+} - V_{TH-}$ )			0.4		V
$I_{OFF}$	Output leakage current on receiver output L1 pin	$nSHDN = 0V$		$\pm 0.05$	$\pm 10$	$\mu A$
$R_I$	Input resistance on receiver input pin (R2)	$-15V \leq V_I \leq 15V$	3	5	7	$k\Omega$
<b>Thermal Protection</b>						
$T_{SD}$	Thermal shutdown threshold	Temperature rising	150	170		$^{\circ}\text{C}$
$T_{HYS}$	Thermal shutdown hysteresis			10		$^{\circ}\text{C}$

Note 1:  $V_{TH+}$  is assured to be at least  $V_{HYS}$  higher than  $V_{TH-}$ .

Note 2: Short-circuit durations should be controlled to prevent exceeding the device absolute power dissipation ratings, and not more than one output should be shorted at a time.

**8.6 Electrical Characteristics (Dynamic)—RS-485\_500kbps**

500kbps (SLR = V<sub>IO</sub>) V<sub>CC</sub> = 3V to 5.5V, V<sub>IO</sub> = 1.65V to 5.5V, T<sub>A</sub> = -40 °C to 125 °C, unless otherwise noted. All typical values are at 25°C and supply voltage of V<sub>CC</sub> = 5 V, V<sub>IO</sub> = 3.3V. (Note 1)

Symbol	Parameter	Conditions	Min	Typ	Max	Unit	
<b>Driver</b>							
t <sub>R</sub> , t <sub>F</sub>	Driver differential output rise/fall time	R <sub>L</sub> = 54 Ω, C <sub>L</sub> = 50 pF, see Figure 9-3	V <sub>CC</sub> = 3 to 3.6 V, Typical at 3.3 V	200	310	600	ns
			V <sub>CC</sub> = 4.5 to 5.5 V, Typical at 5 V	200	310	600	ns
t <sub>PHL</sub> , t <sub>PLH</sub>	Driver propagation delay time		V <sub>CC</sub> = 3 to 3.6 V, Typical at 3.3 V		265	450	ns
			V <sub>CC</sub> = 4.5 to 5.5 V, Typical at 5 V		265	450	ns
t <sub>SK(P)</sub>	Driver differential output pulse skew,  t <sub>PHL</sub> - t <sub>PLH</sub>		V <sub>CC</sub> = 3 to 3.6 V, Typical at 3.3 V		1	70	ns
			V <sub>CC</sub> = 4.5 to 5.5 V, Typical at 5 V		2	70	ns
t <sub>PHZ</sub> , t <sub>PLZ</sub>	Disable time	MODE1, MODE0 = 10 (half duplex) or 11 (full duplex), see Figure 9-4 and Figure 9-5			300	ns	
t <sub>PZH</sub> , t <sub>PZL</sub>	Enable time	MODE1, MODE0 = 11 (full duplex): receiver enabled, see Figure 9-4 and Figure 9-5			10	μs	
<b>Receiver</b>							
t <sub>R</sub> , t <sub>F</sub>	Receiver output rise/fall time	C <sub>L</sub> = 15 pF, see Figure 9-6		8	20	ns	
t <sub>PHL</sub> , t <sub>PLH</sub>	Receiver propagation delay time			640	1200	ns	
t <sub>SK(P)</sub>	Receiver output pulse skew,  t <sub>PHL</sub> - t <sub>PLH</sub>			2	45	ns	
t <sub>PHZ</sub> , t <sub>PLZ</sub>	Disable time in half duplex mode	MODE1, MODE0 = 10, TERM_TX = V <sub>IO</sub> , see Figure 9-7			40	ns	
t <sub>PZH</sub> , t <sub>PZL</sub>	Enable time in half duplex mode				150	ns	
t <sub>PSH</sub> , t <sub>PSL</sub>	Enable time from shutdown with TX disabled in full duplex mode	DIR = 0V; MODE1, MODE0 = 11, see Figure 9-8		7	16	μs	

Note 1: R3, R4 are receiver inputs, R2/R1 are driver outputs in Full duplex mode.

**8.7 Electrical Characteristics (Dynamic)—RS-485\_20Mbps**

20Mbps (SLR = GND)  $V_{CC} = 3V$  to  $5.5V$ ,  $V_{IO} = 1.65V$  to  $5.5V$ ,  $T_A = -40\text{ }^\circ\text{C}$  to  $125\text{ }^\circ\text{C}$ , unless otherwise noted. All typical values are at  $25\text{ }^\circ\text{C}$  and supply voltage of  $V_{CC} = 5V$ ,  $V_{IO} = 3.3V$ . (Note 1)

Symbol	Parameter	Conditions	Min	Typ	Max	Unit	
<b>Driver</b>							
$t_R, t_F$	Driver differential output rise/fall time	$R_L = 54\ \Omega$ , $C_L = 50\ \text{pF}$ , see Figure 9-3	$V_{CC} = 3$ to $3.6V$ , Typical at $3.3V$	4	6	15	ns
			$V_{CC} = 4.5$ to $5.5V$ , Typical at $5V$	4	6	15	ns
$t_{PHL}, t_{PLH}$	Driver propagation delay time		$V_{CC} = 1.65$ to $1.95V$		10	58	ns
			$V_{CC} = 3$ to $3.6V$		10	46	ns
$t_{SK(P)}$	Driver differential output pulse skew, $ t_{PHL} - t_{PLH} $		$V_{CC} = 3$ to $3.6V$ , Typical at $3.3V$		0.4	3.5	ns
			$V_{CC} = 4.5$ to $5.5V$ , Typical at $5V$		0.2	3.5	ns
$t_{PHZ}, t_{PLZ}$	Disable time	MODE1, MODE0 = 10 (half duplex) or 11 (full duplex), see Figure 9-4 and Figure 9-5			90	ns	
$t_{PZH}, t_{PZL}$	Enable time	MODE1, MODE0 = 11 (full duplex): receiver enabled, see Figure 9-4 and Figure 9-5			9	$\mu\text{s}$	
<b>Receiver</b>							
$t_R, t_F$	Receiver output rise/fall time	$C_L = 15\ \text{pF}$ , see Figure 9-6		4.5	10	ns	
$t_{PHL}, t_{PLH}$	Receiver propagation delay time			14	70	ns	
$t_{SK(P)}$	Receiver output pulse skew, $ t_{PHL} - t_{PLH} $				10	ns	
$t_{PHZ}, t_{PLZ}$	Disable time in half duplex mode	MODE1, MODE0 = 10, TERM_TX = $V_{IO}$ , see Figure 9-7		8	80	ns	
$t_{PZH}, t_{PZL}$	Enable time in half duplex mode (includes driver disable time as per setup)			100	160	ns	
$t_{PSH}, t_{PSL}$	Enable time from shutdown with TX disabled in full duplex mode	DIR = 0V; MODE1, MODE0 = 11, see Figure 9-8		6.6	15	$\mu\text{s}$	

Note 1: R3, R4 are receiver inputs, R2/R1 are driver outputs in Full duplex mode.

**8.9 Electrical Characteristics (Dynamic)—RS-232\_250kbps**

$V_{CC} = 3V$  to  $5.5V$ ,  $V_{IO} = 1.65V$  to  $5.5V$ ,  $T_A = -40\text{ }^\circ\text{C}$  to  $125\text{ }^\circ\text{C}$ , unless otherwise noted. All typical values are at  $25\text{ }^\circ\text{C}$  and supply voltage of  $V_{CC} = 5V$ ,  $V_{IO} = 3.3V$ . (Note 1)

Symbol	Parameter	Conditions	Min	Typ	Max	Unit
<b>Driver</b>						
$DR_{MAX}$	Maximum data rate	$R_L = 3k\Omega$ , $C_L = 2500\text{ pF}$ , one DOUT switching, see Figure 9-10			250	kbps
$t_{PLH}$ , $t_{PHL}$	Transmitter propagation delay	$R_L = 3k\Omega$ to $7k\Omega$ , $C_L = 150\text{ pF}$ to $2500\text{ pF}$ , see Figure 9-10			2	$\mu\text{s}$
$t_{SK(P)}$	Transmitter Pulse skew				600	ns
$SR_{TR}$	Transition region Slew rate	$V_{CC} = 3.3V \pm 10\%$ or $5V \pm 10\%$ , $R_L = 3k\Omega$ to $7k\Omega$ , $C_L = 150\text{ pF}$ to $1000\text{ pF}$ , see Figure 9-11	6		30	$V/\mu\text{s}$
		$V_{CC} = 3.3V \pm 10\%$ or $5V \pm 10\%$ , $R_L = 3k\Omega$ to $7k\Omega$ , $C_L = 150\text{ pF}$ to $2500\text{ pF}$ , see Figure 9-11	4		30	$V/\mu\text{s}$
<b>Receiver</b>						
$t_{PLH}$	Propagation delay time, low- to high-level output	$C_L = 150\text{ pF}$ , see Figure 9-12		150	550	ns
		$C_L = 15\text{ pF}$ , see Figure 9-12		110	520	ns
$t_{PHL}$	Propagation delay time, high- to low-level output	$C_L = 150\text{ pF}$ , see Figure 9-12		150	550	ns
		$C_L = 15\text{ pF}$ , see Figure 9-12		110	520	ns
$t_{R(232)}$ , $t_{F(232)}$	Rise/fall time (receiver buffer output), $V_{IO} = 3$ to $5.5V$	$C_L = 150\text{ pF}$ , see Figure 9-12		20	50	ns
		$C_L = 15\text{ pF}$ , see Figure 9-12		7	13	ns
	Rise/fall time (receiver buffer output), $V_{IO} = 1.65$ to $2.75V$	$C_L = 150\text{ pF}$ , see Figure 9-12		40	110	ns
		$C_L = 15\text{ pF}$ , see Figure 9-12		15	30	ns
$t_{EN}$	Output enable time	$C_L = 150\text{ pF}$ , $R_L = 3k\Omega$ , See Figure 9-13		2.8	14	$\mu\text{s}$
$t_{DIS}$	Output disable time			135	400	ns
$t_{SK(P)}$	Receiver output pulse skew, $ t_{PHL} - t_{PLH} $	$C_L = 150\text{ pF}$ , see Figure 9-12			125	ns
		$C_L = 15\text{ pF}$ , see Figure 9-12			125	ns

Note 1: Test conditions are  $C1-C4 = 0.1\mu\text{F}$  at  $V_{CC} = 3.3V \pm 0.3V$  and  $V_{CC} = 5V \pm 0.5V$ .

**8.10 Electrical Characteristics (Dynamic)—RS-232\_1Mbps**

$V_{CC} = 3V$  to  $5.5V$ ,  $V_{IO} = 1.65V$  to  $5.5V$ ,  $T_A = -40^\circ C$  to  $125^\circ C$ , unless otherwise noted. All typical values are at  $25^\circ C$  and supply voltage of  $V_{CC} = 5V$ ,  $V_{IO} = 3.3V$ . (Note 1)

Symbol	Parameter	Conditions	Min	Typ	Max	Unit
<b>Driver</b>						
DR <sub>MAX</sub>	Maximum data rate	$R_L = 3k\Omega$ , $C_L = 250$ pF, $V_{CC} = 3$ to $3.6V$ , one DOUT switching, see Figure 9-10			1000	kbps
		$R_L = 3k\Omega$ , $C_L = 1000$ pF, $V_{CC} = 4.5$ to $5.5V$ , one DOUT switching, see Figure 9-10			1000	kbps
$t_{PLH}$ , $t_{PHL}$	Transmitter propagation delay	$R_L = 3k\Omega$ to $7k\Omega$ , $C_L = 150$ pF to $1000$ pF, see Figure 9-10			800	ns
$t_{SK(P)}$	Transmitter Pulse skew				150	ns
SR <sub>TR</sub>	Transition region Slew rate	$V_{CC} = 4.5$ to $5.5V$ , $R_L = 3k\Omega$ to $7k\Omega$ , $C_L = 150$ pF to $1000$ pF, see Figure 9-11	18		150	V/ $\mu$ s
		$V_{CC} = 3$ to $3.6V$ , $R_L = 3k\Omega$ to $7k\Omega$ , $C_L = 150$ pF to $1000$ pF, see Figure 9-11	15		150	V/ $\mu$ s
<b>Receiver</b>						
$t_{PLH}$	Propagation delay time, low- to high-level output	$C_L = 150$ pF, see Figure 9-12		150	550	ns
		$C_L = 15$ pF, see Figure 9-12		110	520	ns
$t_{PHL}$	Propagation delay time, high- to low-level output	$C_L = 150$ pF, see Figure 9-12		150	550	ns
		$C_L = 15$ pF, see Figure 9-12		110	520	ns
$t_{R(232)}$ , $t_{F(232)}$	Rise/fall time (receiver buffer output)	$C_L = 150$ pF, see Figure 9-12		20	50	ns
		$C_L = 15$ pF, see Figure 9-12		7	13	ns
	Rise/fall time (receiver buffer output), $V_{IO} = 1.65$ to $2.75V$	$C_L = 150$ pF, see Figure 9-12		40	110	ns
		$C_L = 15$ pF, see Figure 9-12		15	30	ns
$t_{EN}$	Output enable time	$C_L = 150$ pF, $R_L = 3k\Omega$ , See Figure 9-13		2.8	14	$\mu$ s
$t_{DIS}$	Output disable time			135	400	ns
$t_{SK(P)}$	Receiver output pulse skew, $ t_{PHL} - t_{PLH} $	$C_L = 150$ pF, see Figure 9-12			125	ns
		$C_L = 15$ pF, see Figure 9-12			125	ns

Note 1: Test conditions are  $C1-C4 = 0.1\mu F$  at  $V_{CC} = 3.3V \pm 0.3V$  and  $V_{CC} = 5V \pm 0.5V$ .

**9 Parameter Measurement Information**

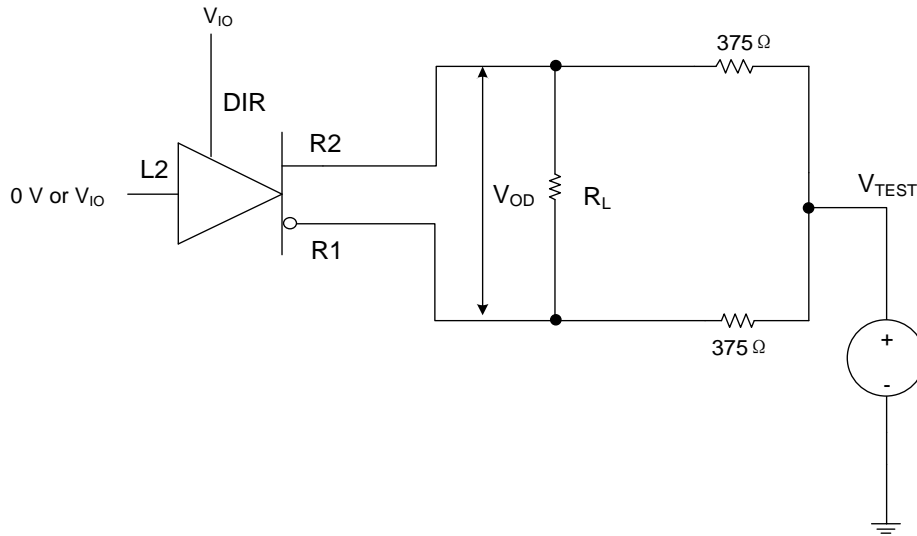


Figure 9-1. Measurement of RS-485 Driver Differential Output Voltage With Common-Mode Load

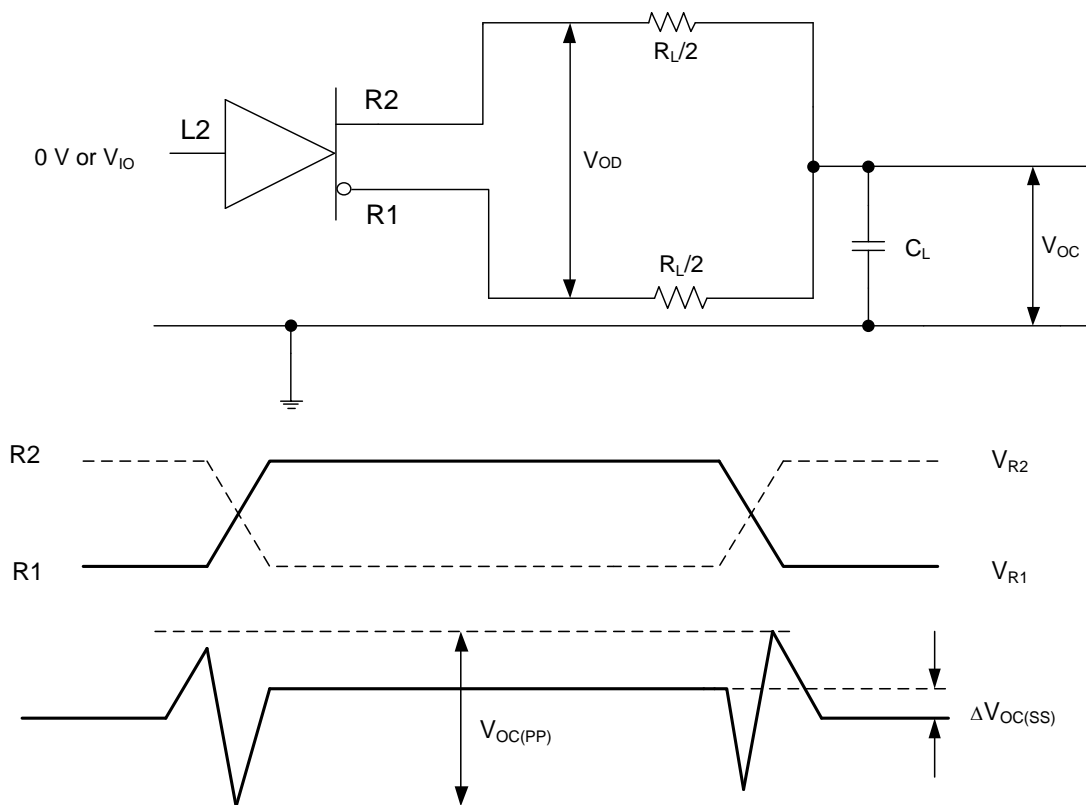


Figure 9-2. Measurement of RS-485 Driver Differential and Common-Mode Output With RS-485 Load

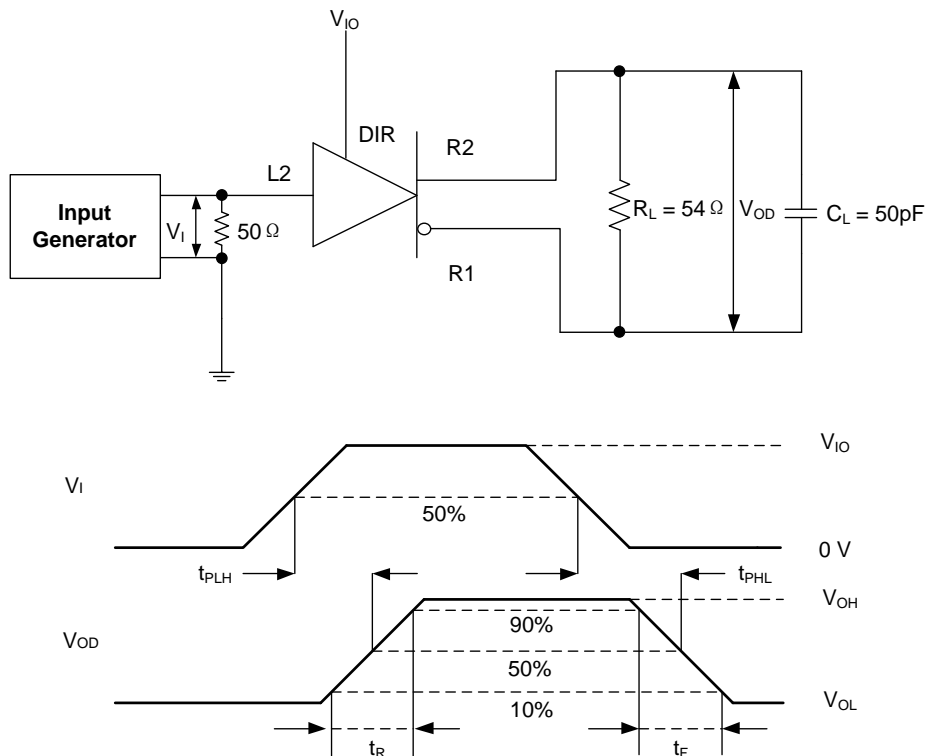
**9 Parameter Measurement Information (continued)**


Figure 9-3. Measurement of RS-485 Driver Differential Output Rise and Fall Times and Propagation Delays

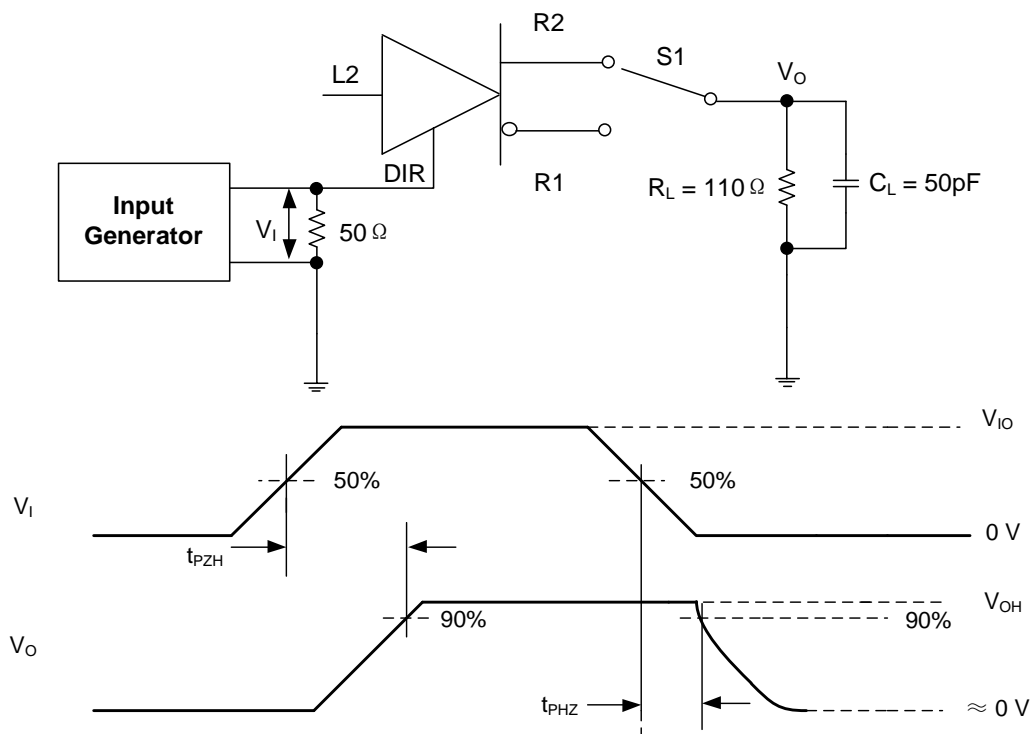


Figure 9-4. Measurement of RS-485 Driver Enable and Disable Times With Active High Output and Pull-Down Load

**9 Parameter Measurement Information (continued)**

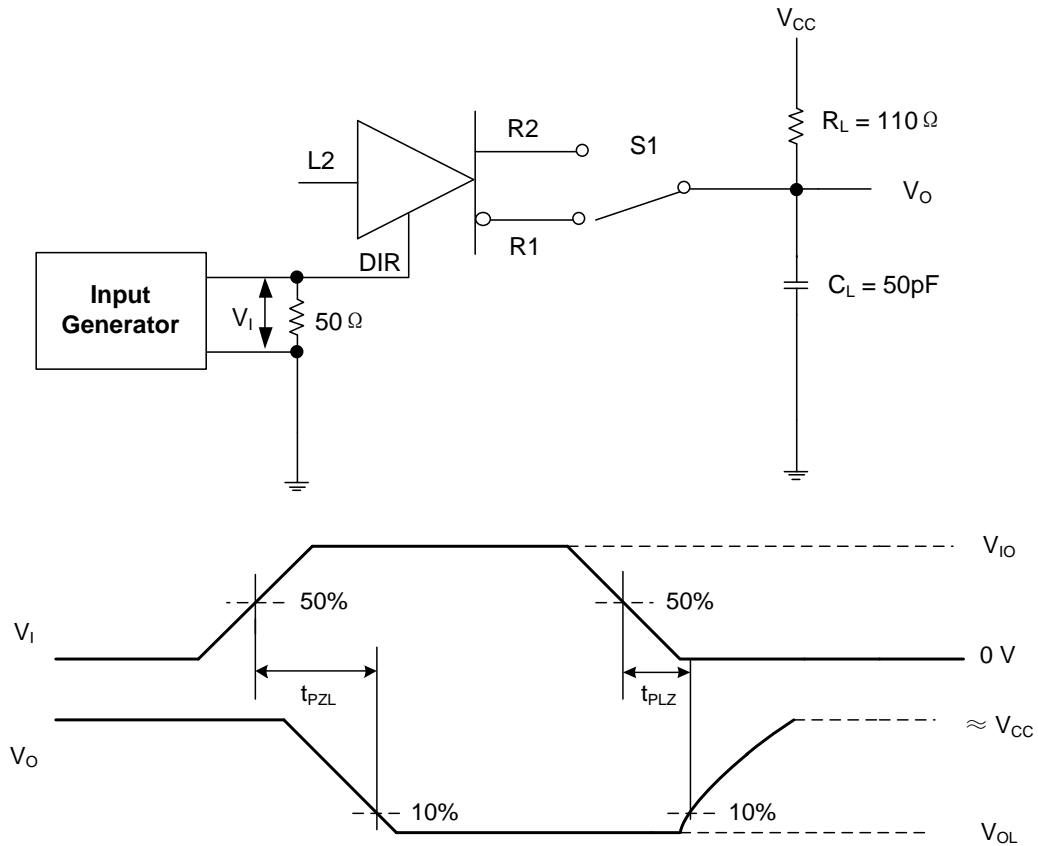
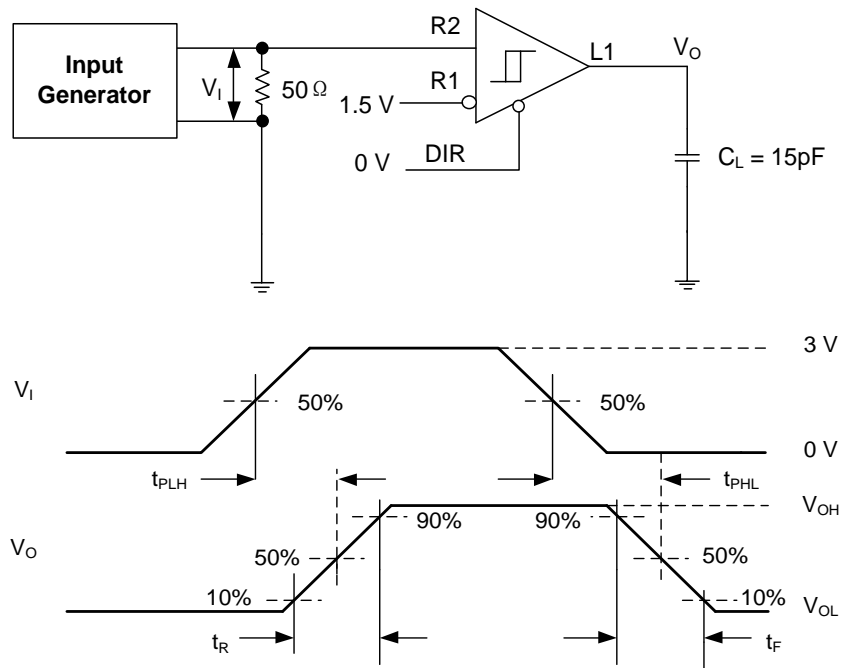


Figure 9-5. Measurement of RS-485 Driver Enable and Disable Times with Active Low Output and Pull-up Load



Note 1: Input terminals are R1 and R2 in half duplex mode, R3 and R4 in Full duplex mode

Figure 9-6. Measurement of RS-485 Receiver Output Rise and Fall Times and Propagation Delays

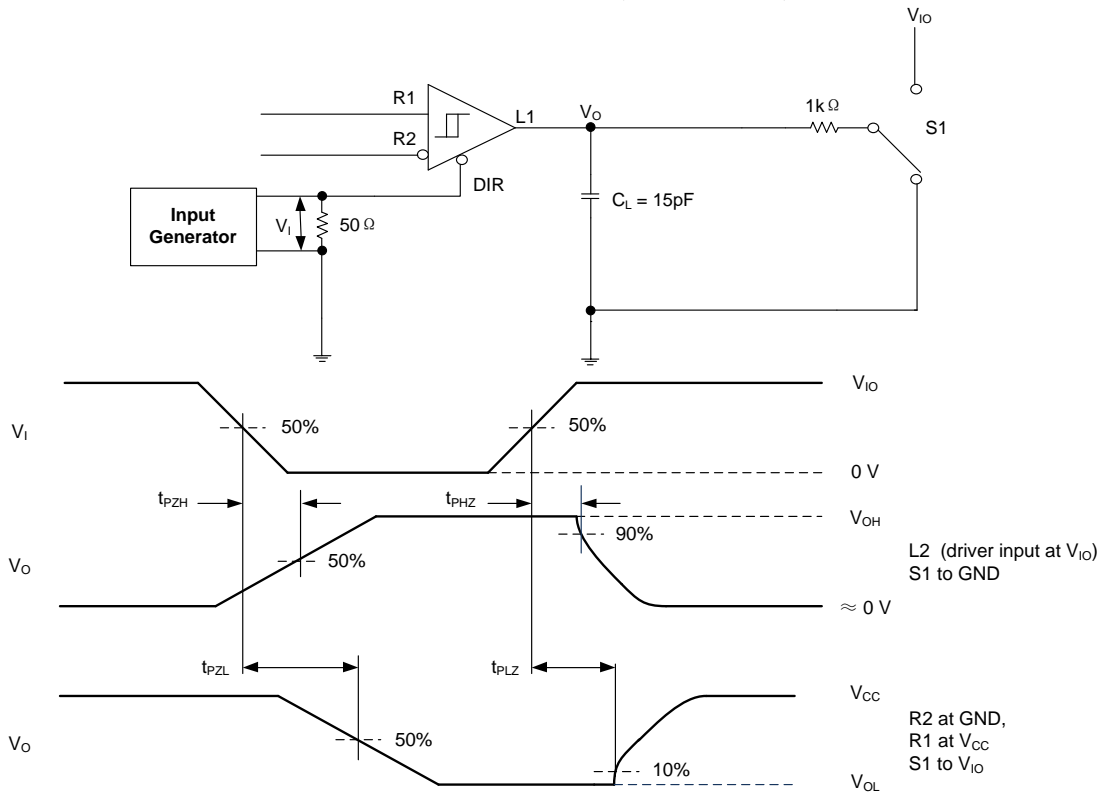
**9 Parameter Measurement Information (continued)**


Figure 9-7. Measurement of RS-485 Receiver Enable and Disable Times in Half Duplex Mode

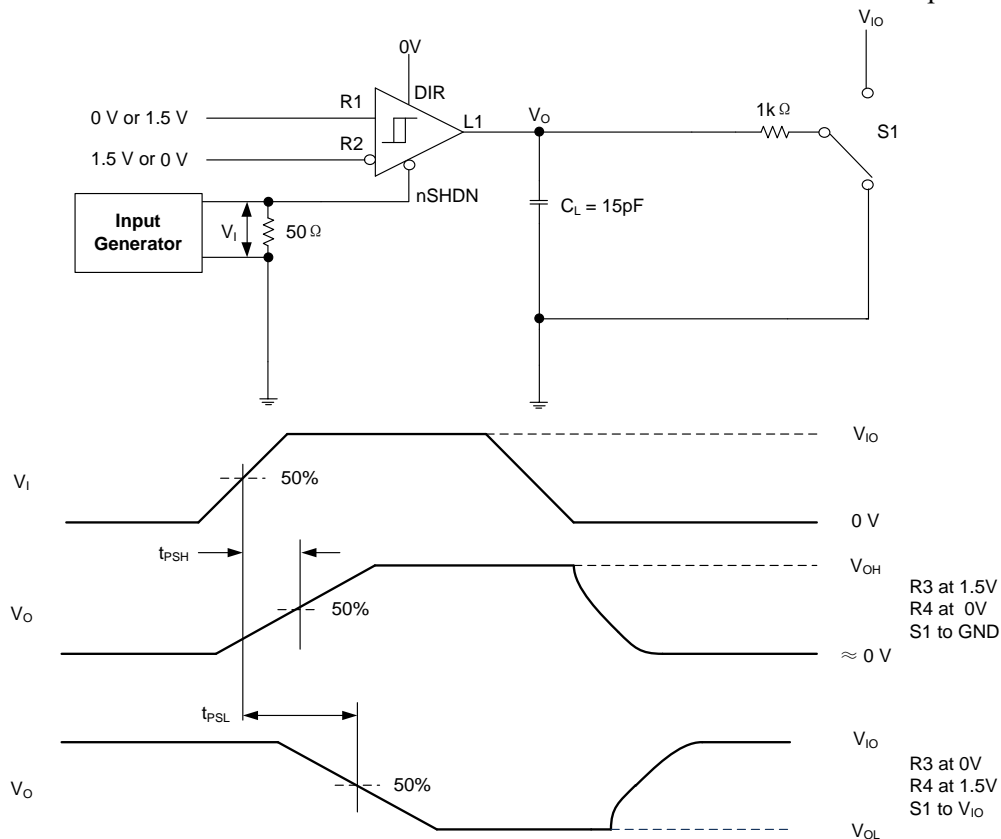


Figure 9-8. Measurement of RS-485 Receiver Enable Time from Shutdown with TX Disabled: Full Duplex Mode

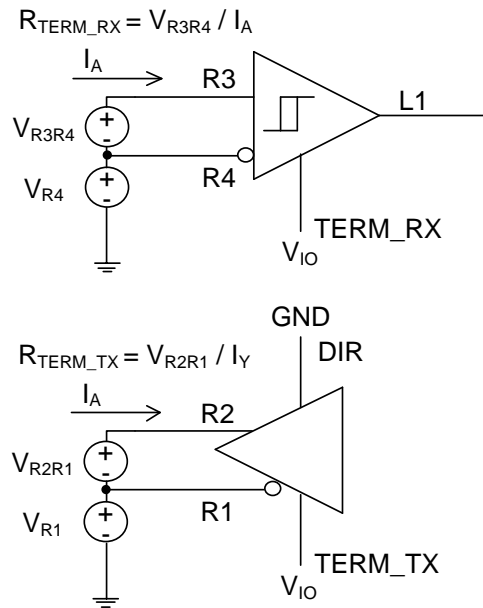
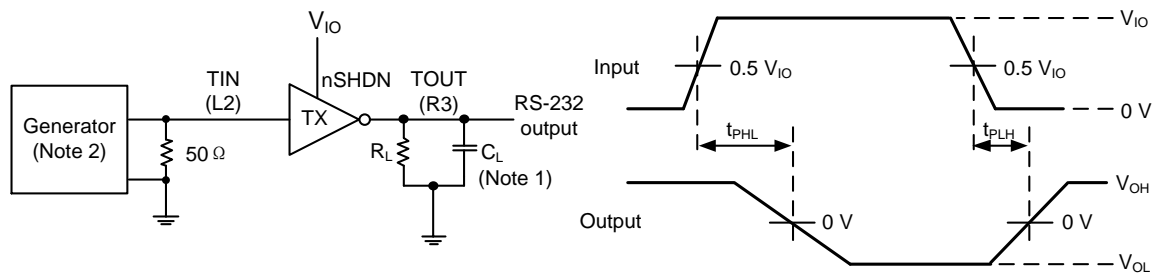
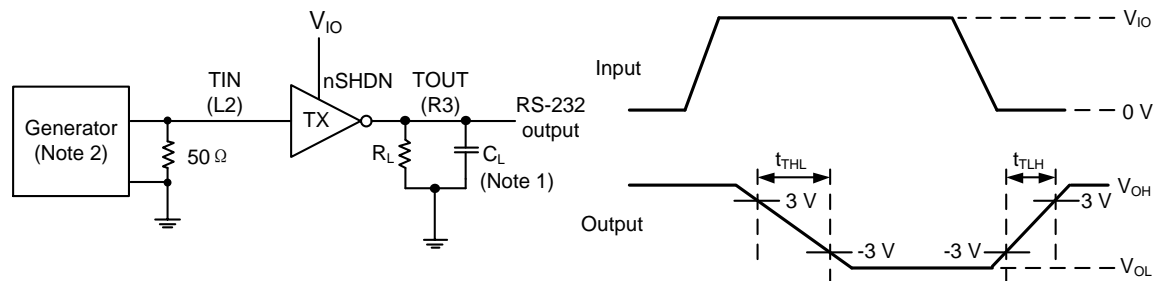
**9 Parameter Measurement Information(continued)**


Figure 9-9. Termination Resistor Measurement


 Note 1:  $C_L$  includes probe and jig capacitance.

 Note 2: The pulse generator has the following characteristics: PRR = 250 kbps and 1 Mbit/s, 50% duty cycle,  $t_r \leq 10$  ns,  $t_f \leq 10$  ns.

Figure 9-10. RS-232 Driver Prop Delay, Pulse Skew


 Note 1:  $C_L$  includes probe and jig capacitance.

 Note 2: The pulse generator has the following characteristics: PRR = 250 kbps and 1 Mbit/s, 50% duty cycle,  $t_r \leq 10$  ns,  $t_f \leq 10$  ns.

 Note 3:  $SR = 6 \text{ V} / (t_{THL} \text{ or } t_{TLH})$ .

Figure 9-11. RS-232 Driver Slew Rate

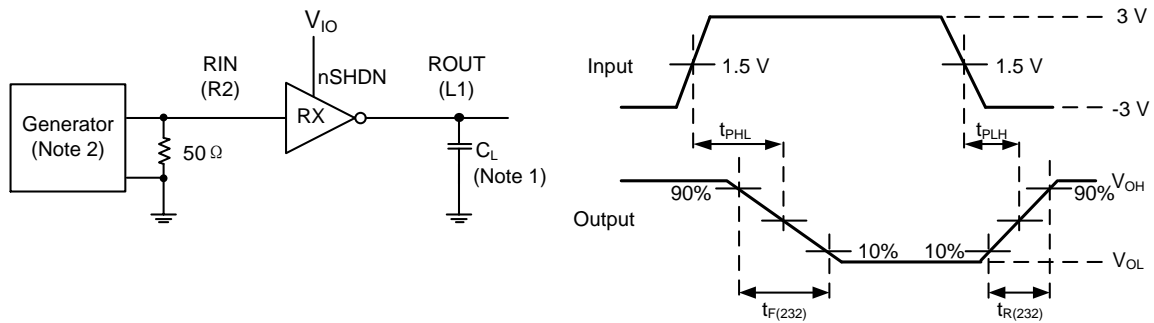
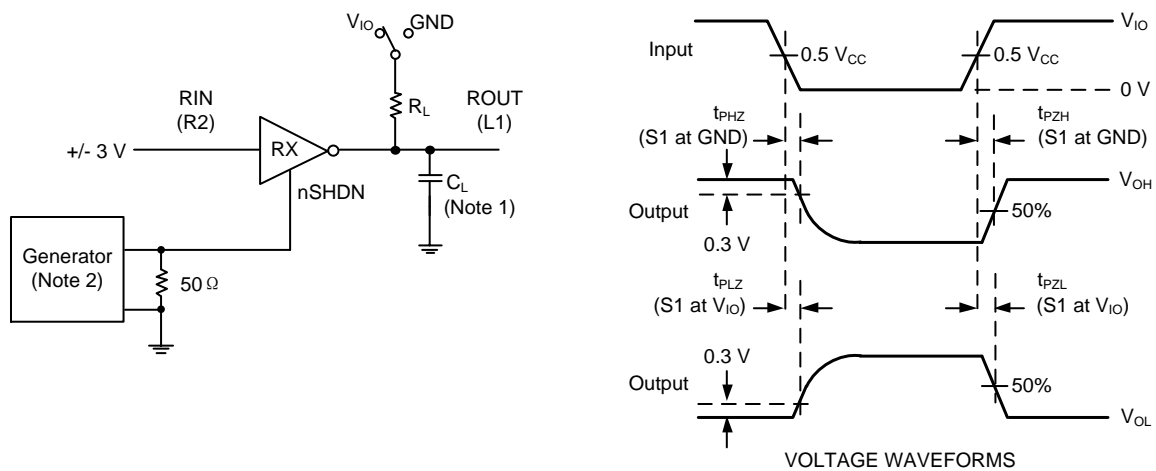
**9 Parameter Measurement Information (continued)**


Figure 9-12. RS-232 Receiver Propagation Delay, Pulse Skew


 Note 1:  $C_L$  includes probe and jig capacitance.

 Note 2: The pulse generator has the following characteristics: 50% duty cycle,  $t_R \leq 10$  ns,  $t_F \leq 10$  ns.

 Note 3:  $t_{PLZ}$  and  $t_{PHZ}$  are same as  $t_{DIS}$ ,  $t_{PZL}$  and  $t_{PZH}$  are same as  $t_{EN}$ .

Figure 9-13. RS-232 Receiver Enable and Disable Time

## 10 Detailed Description

### 10.1 Overview

The UM3011 is an advanced and robust multiprotocol transceiver supporting RS-232, RS-422 and RS-485 physical layers in a QFN24 4.0×4.0 package. Integrated cable termination and configuration modes allow RS-232, RS-422 and RS-485 protocols to be used interchangeably over a single cable or connector with no additional components. The device has one transmitter and one receiver to enable 1T1R RS-232 port or half and full duplex RS-485 port.

The device has SLR pin which allows it to be used for two different maximum speed settings for RS-232 and for RS-485. This is beneficial as customers can qualify one device and use it in two separate end-applications.

### 10.2 Functional Block Diagram

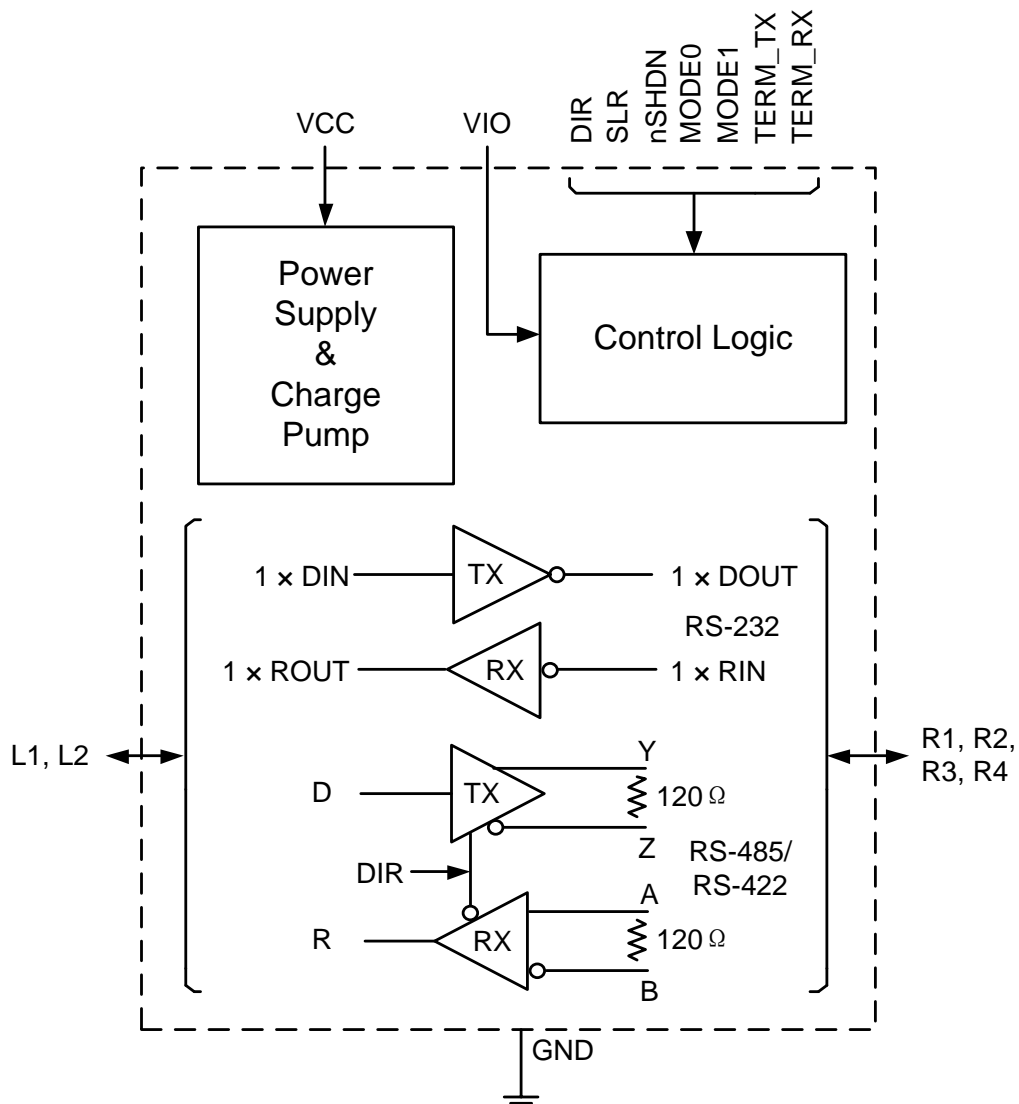


Figure 10-1. UM3011 Block Diagram

## 10.3 Device Functional Modes

The UM3011 is a highly integrated and robust multiprotocol transceiver supporting RS-232, RS-422 and RS-485 physical layers. The device features 2 mode selection pins (MODE1, MODE0) to enable switching between three different operating modes (RS-232 1T1R Mode, RS-485 Half duplex and RS-422 Full duplex mode).

### 10.3.1 RS-232 1T1R Mode: 01 (MODE1, MODE0)

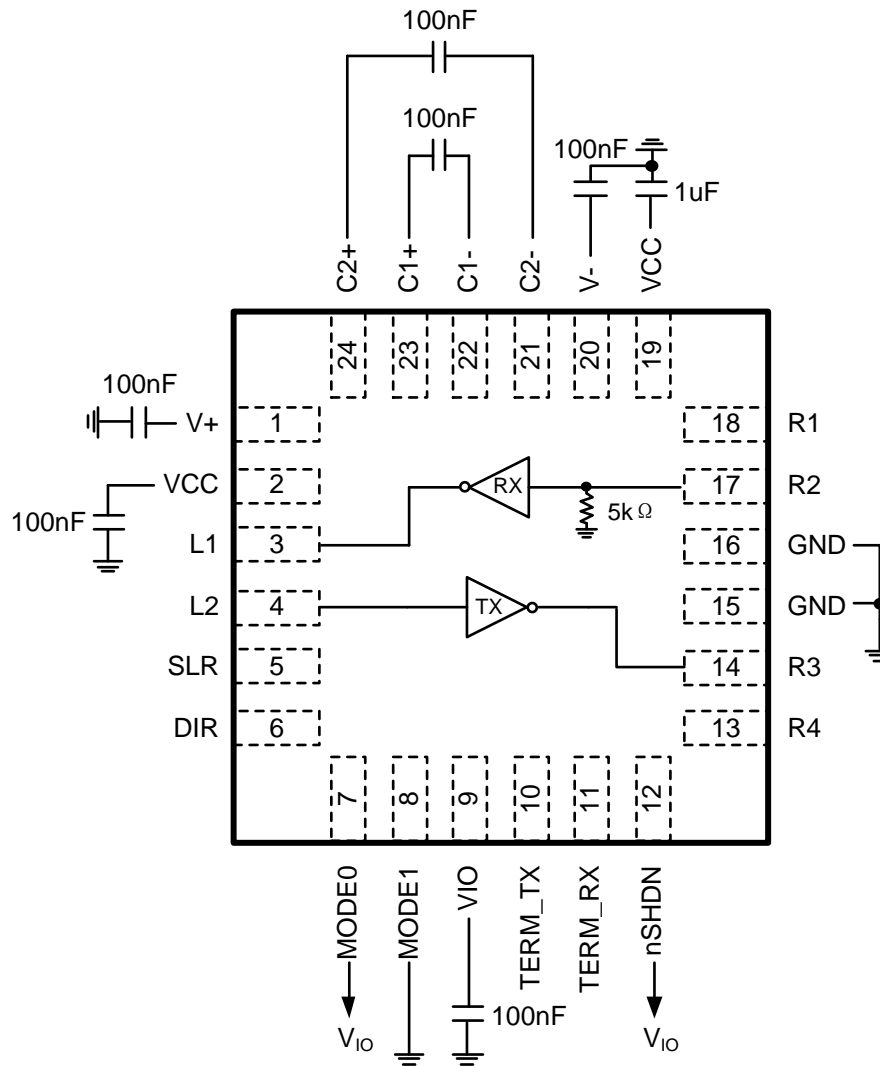


Figure 10-2. UM3011 RS-232 1T1R Mode



**10.3.3 RS-485 Full Duplex Mode: 11 (MODE1, MODE0)**

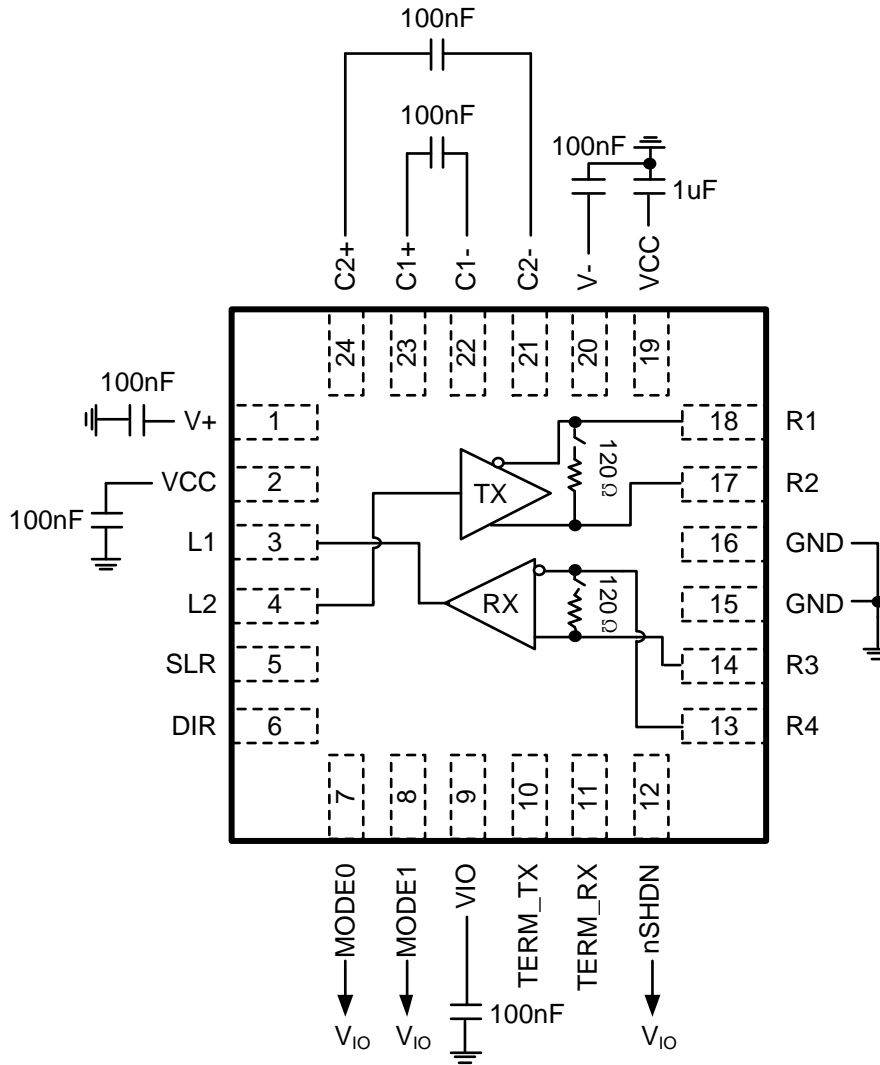


Figure 10-4. UM3011 RS-485 Full duplex Mode

### 10.3.4 Mode Control

The UM3011 has 2 mode selection pins (MODE1, and MODE0) with 3 different modes. The mode controls for the UM3011 are listed in the table below:

Table 10-1. MODE Control Function Table for UM3011 (Note1)

MODE1	MODE0	Operating mode	Function
L	H	RS-232 1T1R mode, charge pump is ON, V+/V- are regulated	1T1R mode; L2 is Logic input for RS232 driver; L1 is Logic output. See Figure 10-2.
H	L	RS-485 half duplex mode (charge pump is off)	L1 is RX Logic output; L2 is Driver Logic input; R1, R2 are Bus inverting and non-inverting terminals respectively. See Figure 10-3.
H	H	RS-485 full duplex mode (charge pump is off)	R1, R2 are inverting and non-inverting driver terminals; R3, R4 are non-inverting and inverting receiver terminals. See Figure 10-4.

Note 1: ‘H’ represents logic high, ‘L’ represents logic low.

### 10.3.5 RS-485 Functionality

When the driver enable pin, DIR, is logic high, the differential outputs R2 and R1 follow the logic states at data input L2. A logic high at L2 causes R2 to turn high and R1 to turn low. In this case, the differential output voltage defined as  $V_{OD} = V_{R2} - V_{R1}$  is positive. When L2 is low, the output states reverse: R1 turns high, R2 becomes low, and  $V_{OD}$  is negative.

When DIR is low, both outputs turn high-impedance. In this condition, the logic state at L2 is irrelevant. The DIR pin has an internal pull-down resistor to ground, thus when left open the driver is disabled (high-impedance) by default. The L2 pin has an internal pull-up resistor to  $V_{IO}$ , thus, when left open while the driver is enabled, output R2 turns high and R1 turns low.

Table 10-2 is valid for both RS-485 half duplex and full duplex modes, and is independent of state of TERM\_TX, TERM\_RX and SLR pins.

**10.3.5 RS-485 Functionality (continued)**

Table 10-2. Driver Function Table

Enable	Input	Outputs		Function
		R2	R1	
DIR	L2	R2	R1	
H	H	H	L	Actively drive bus high
H	L	L	H	Actively drive bus low
H	Open	H	L	Actively drive bus high by default
L	X	High impedance	High impedance	Driver disabled
Open	X	High impedance	High impedance	Driver disabled by default

In RS-485 full duplex mode, if nSHDN is high, receiver is always enabled. In RS-485 half duplex mode, receiver is enabled if DIR = Low/float and disabled if DIR =  $V_{IO}$ . When the differential input voltage defined as  $V_{ID} = V_{R2} - V_{R1}$  or  $V_{R3} - V_{R4}$  is higher than the positive input threshold,  $V_{TH+}$ , the receiver output, L1, turns high. When  $V_{ID}$  is lower than the negative input threshold,  $V_{TH-}$ , the receiver output, L1, turns low. If  $V_{ID}$  is between  $V_{TH+}$  and  $V_{TH-}$ , the output is indeterminate.

Internal biasing of the receiver inputs causes the output to go failsafe-high when the transceiver is disconnected from the bus (open-circuit), the bus lines are shorted to one another (short-circuit), or the bus is not actively driven (idle bus).

In half duplex mode, when DIR is high, the receiver output is high-impedance and the magnitude and polarity of  $V_{ID}$  are irrelevant.

Table 10-3 is valid irrespective of state of TERM\_TX, TERM\_RX and SLR pins.

Table 10-3. Receiver Function Table

Differential Input	Output	Function
$V_{ID}$	L1	
$V_{TH+} < V_{ID}$	H	Receive valid bus high
$V_{TH-} < V_{ID} < V_{TH+}$	?	Indeterminate bus state
$V_{ID} < V_{TH-}$	L	Receive valid bus low
X	High impedance for DIR = $V_{IO}$ in Half duplex mode	Receiver disabled in half duplex mode for DIR = $V_{IO}$
Open-circuit bus, Short-circuit bus, Idle (terminated) bus	H	Fail-safe high output

### 10.3.6 RS-232 Functionality

In RS-232 mode, only way to disable driver is to go in shutdown mode by pulling nSHDN pin low. A logic high at input for driver L2 causes driver output R3 to be driven low towards negative charge pump output V-. A logic low at input for driver L2 causes driver output R3 to be driven high towards positive charge pump output V+. If logic input is left floating due to the pull-up resistors on driver logic inputs, the driver output is driven low towards V-. Table 10-4 shows the driver functions.

Table 10-4. Driver Function Table

Enable	Inputs	Outputs	Function
nSHDN	L2	R3	
H	H	L (driven towards V-)	Normal operation with inverting logic
H	L	H (driven towards V+)	Normal operation with inverting logic
H	Open	L (driven towards V-)	Since pull-up on logic input pin, output driven low by default
L	X	High impedance	TX and RX are disabled in shutdown mode

For the RS-232 receiver, if the receiver bus input is above rising threshold  $V_{TH+}$ , corresponding received logic output goes low. Also, if the receiver bus input is below falling threshold  $V_{TH-}$ , corresponding received logic output goes high. Table 10-5 shows the receiver functions.

Table 10-5. Receiver Function Table

RS-232 Bus Inputs	Outputs	Function
$V_{IRX}$ (voltage on R2)	L1	
$V_{TH+} < V_{IRX}$	L	Normal operation with inverting logic
$V_{TH-} < V_{IRX} < V_{TH+}$	?	Indeterminate bus state
$V_{IRX} < V_{TH-}$	H	Since pull-up on logic input pin, output driven low by default
X	High impedance for nSHDN = GND	Receiver disabled in shutdown mode
Open-circuit bus	H	Fail-safe high output

## 10.4 Feature Description

### 10.4.1 Device Protection Features

The UM3011's bus pins are protected against any DC supply shorts in the range of -16 V to +16 V. In the RS-485 mode, the short circuit current is limited to  $\pm 250$  mA to comply with the TIA/EIA-485A standard. In RS-232 mode, current limiting of  $\pm 60$  mA is applicable for scenarios where bus pins can short to ground.

The UM3011 also features thermal shutdown protection that disables the driver and the receiver if the junction temperature exceeds the  $T_{SD}$  threshold due to excessive power dissipation on-chip.

Supply undervoltage protection is present on  $V_{CC}$  and  $V_{IO}$  supply pins. This maintains the bus output and receiver logic output in known driven state when both the supplies are above their rising undervoltage thresholds. Table 10-6 describes the device behavior in various scenarios of supply levels.

Table 10-6. Supply Function Table

$V_{CC}$	$V_{IO}$	Driver Output	Receiver Output
$> V_{UVD(RIS)VCC}$	$> V_{UVD(RIS)VIO}$	For RS-485 mode, determined by DIR and L2 inputs. For RS-232 mode, determined by L2 input. For shutdown mode, Hi-Z	For RS-485 mode, determined by DIR and (R1-R2) or (R3- R4) inputs. For RS-232 mode, determined by R2 input. For shutdown mode, Hi-Z
$> V_{UVD(RIS)VCC}$	$< V_{UVD(RIS)VIO}$	High impedance	High impedance
$< V_{UVD(RIS)VCC}$	$> V_{UVD(RIS)VIO}$	High impedance	Undetermined
$< V_{UVD(RIS)VCC}$	$< V_{UVD(RIS)VIO}$	High impedance	High impedance

### 10.4.2 RS-485 Receiver Fail-Safe Operation

The RS-485 differential receiver of the UM3011 is failsafe to invalid bus states caused by the following conditions:

- Open bus conditions, such as a disconnected connector
- Shorted bus conditions, such as cable damage shorting the twisted-pair together
- Idle bus conditions that occur when no driver on the bus is actively driving

In any of these cases, the fail-safe operation brings a logic high state on receiver outputs so that avoid the indeterminate output of the receiver.

### 10.4.3 Integrated Switchable Termination Resistor

The UM3011 has 2 termination resistors of nominal 120 Ω. When in RS-485 full duplex mode, the termination resistor is configured between R1/R2 and R3/R4 buses. When in RS-485 half duplex mode, the termination resistor is configured between R1/R2 buses. Both termination resistors are enabled or disabled using pins as described in Table 10-7.

Termination resistor is OFF in RS-232 mode, unpowered and thermal shutdown modes.

Table 10-7. Integrated Termination Function for UM3011

Device mode	Signal state	Function	Notes
RS-485 Full duplex mode	TERM_TX = V <sub>IO</sub>	120 Ω enabled between R1 and R2	Termination between R1/R2 is disabled by default
	TERM_TX = GND or float	120 Ω disabled between R1 and R2	
	TERM_RX = V <sub>IO</sub>	120 Ω enabled between R3 and R4	Termination between R3/R4 is disabled by default
	TERM_RX = GND or float	120 Ω disabled between R3 and R4	
RS-485 Half duplex mode	TERM_RX = X, TERM_TX = V <sub>IO</sub>	120 Ω enabled between R1 and R2	In half duplex mode, TERM_RX is don't care and TERM_TX has higher priority
	TERM_RX = X, TERM_TX = GND	120 Ω disabled between R1 and R2	

The termination block offers a resistive load to the bus, and does not alter the magnitude or phase of the bus signals from DC to 20Mbps signaling. The Integrated 120 Ω termination resistor is designed for minimum variation across temperature and across common mode voltage on bus pins.

### 10.4.4 Switchable Operating Data Rates

The UM3011 can be used in slow speed or fast speed RS-485 and RS-232 applications by configuring Slew rate control (SLR) pin and. Table 10-8 describes slew rate control function for the UM3011.

Table 10-8. Slew Rate Control Function for UM3011

SLR configuration	Maximum speed of Driver	Maximum speed of Receiver	Notes
SLR = V <sub>IO</sub>	RS-485 mode: 500kbps RS-232 mode: 250kbps	RS-485 mode: 500kbps RS-232 mode: 250kbps	Active high slew rate limiting applied on driver output. In this configuration, glitch filter in receiver path for RS-485 is enabled
SLR = GND or float	RS-485 mode: 20Mbps RS-232 mode: 1Mbps	RS-485 mode: 20Mbps RS-232 mode: 1Mbps	Slew rate limiting on driver output disabled.

For RS-485 half and full duplex modes, receiver path in the slow speed mode provides additional noise filtering. To attenuate high frequency noise pulses from the bus which can be wrongly interpreted as valid data.

## 10.4.5 Integrated Charge pump for RS-232

The UM3011 has integrated high-efficiency and low-noise charge pump to generate large output voltages for RS-232 signals. Charge pump consists of a voltage doubler and an inverter to regulate the voltage to nominal  $\pm 5.5V$  or to  $\pm 8.5V$  for 3.3V or 5V  $V_{CC}$  operation respectively. Charge pump needs four external ceramic capacitors (2 flying capacitors and 2 storage capacitors) and allows for single supply operation for RS-232.

## 11 Application and Implementation

### 11.1 Application Information

The UM3011 is highly integrated multiprotocol transceivers supporting RS-232, RS-422 and RS-485 physical layer and is used for asynchronous data transmissions. Two MODE pins allow for the configuration of different operating modes. The device allows point-to-point RS-232 communication port and multipoint RS-485 communication port over common connector. The device also features integrated  $120\Omega$  switchable termination resistor on RS-485 bus lines which enables same device to be used for middle nodes or end nodes in an RS-485 network. When the device is configured in RS-232 mode, RS-485 circuits and  $120\Omega$  termination are disabled and do not interfere in RS-232 communication. For RS-232 communication, charge pump and  $5k\Omega$  resistor to ground on receiver bus pins is integrated in the device. This  $5k\Omega$  resistor and charge pump is automatically disabled in RS-485 mode. Slew rate limiting pin is provided so that same device can be used in slow speed or fast speed RS-485 and RS-232 applications. All these features make the devices completely flexible and suitable for various application needs. Integration of termination resistor saves significant PCB area compared to discrete implementation.

### 11.1 Typical Application

The UM3011 consists of 1 driver and 1 receiver and dual charge pump circuit to enable RS-232 point-to-point serial communication. The device provides the electrical interface between an asynchronous communication controller and the serial-port connector.

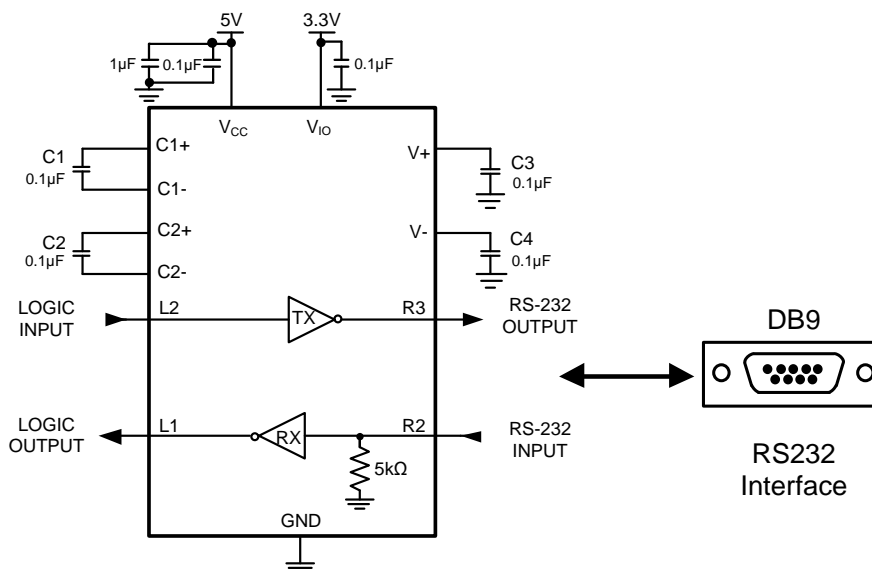


Figure 11-1. RS-232 serial communication

## 11.1 Typical Application (continued)

An RS-485 bus consists of multiple transceivers connecting in parallel to a bus cable. To eliminate line reflections, each cable end is terminated with a termination resistor,  $R_T$ , whose value matches the characteristic impedance,  $Z_0$ , of the cable. This method, known as parallel termination, generally allows for higher data rates over longer cable length.

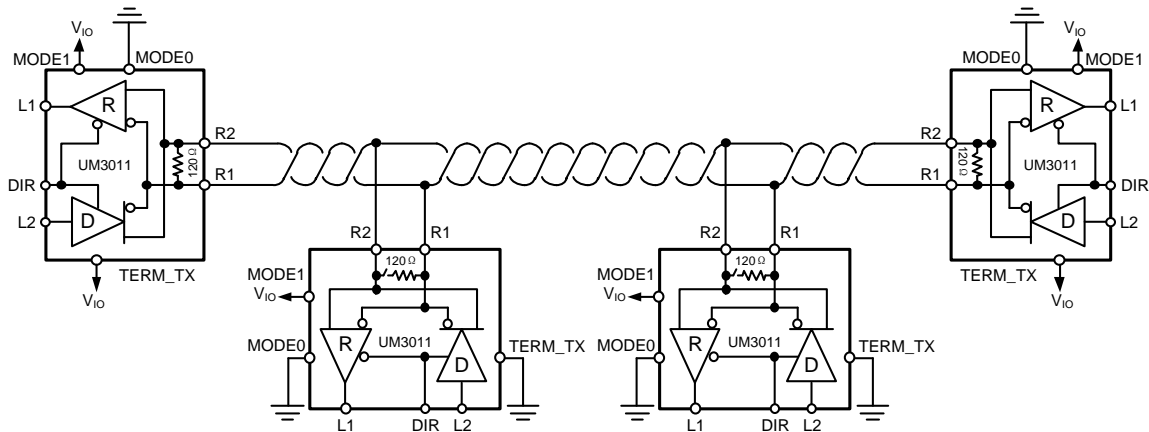


Figure 11-2. Typical RS-485 Network with Half-Duplex Transceivers

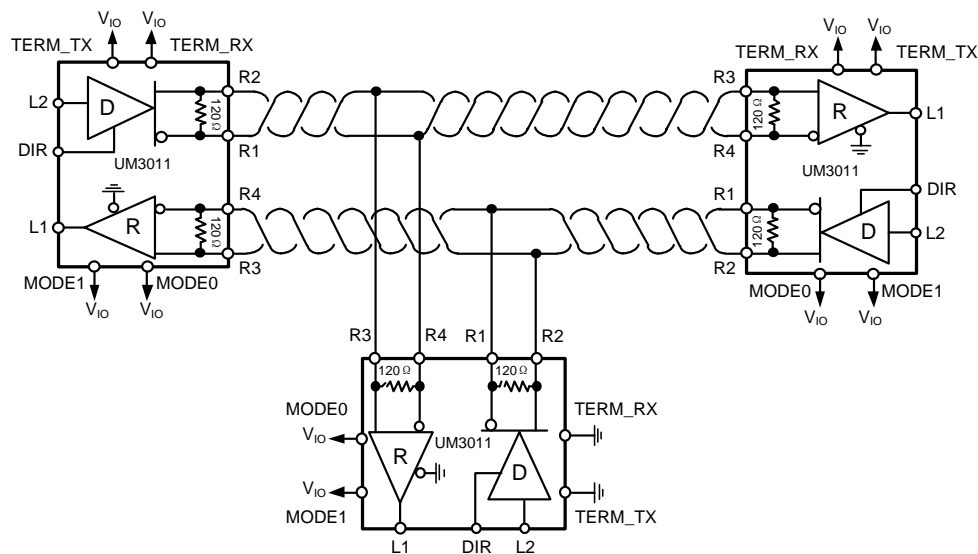
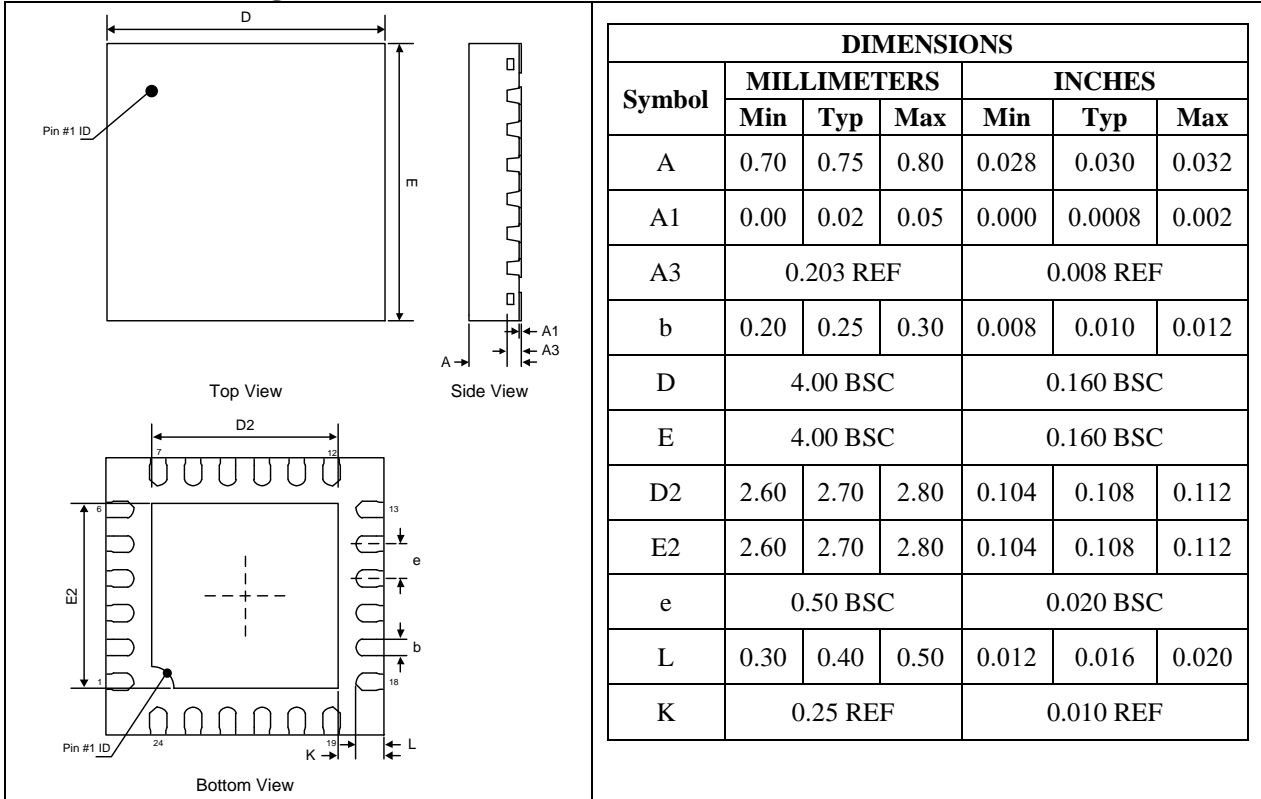


Figure 11-3. Typical RS-485 Network with Full-Duplex Transceivers

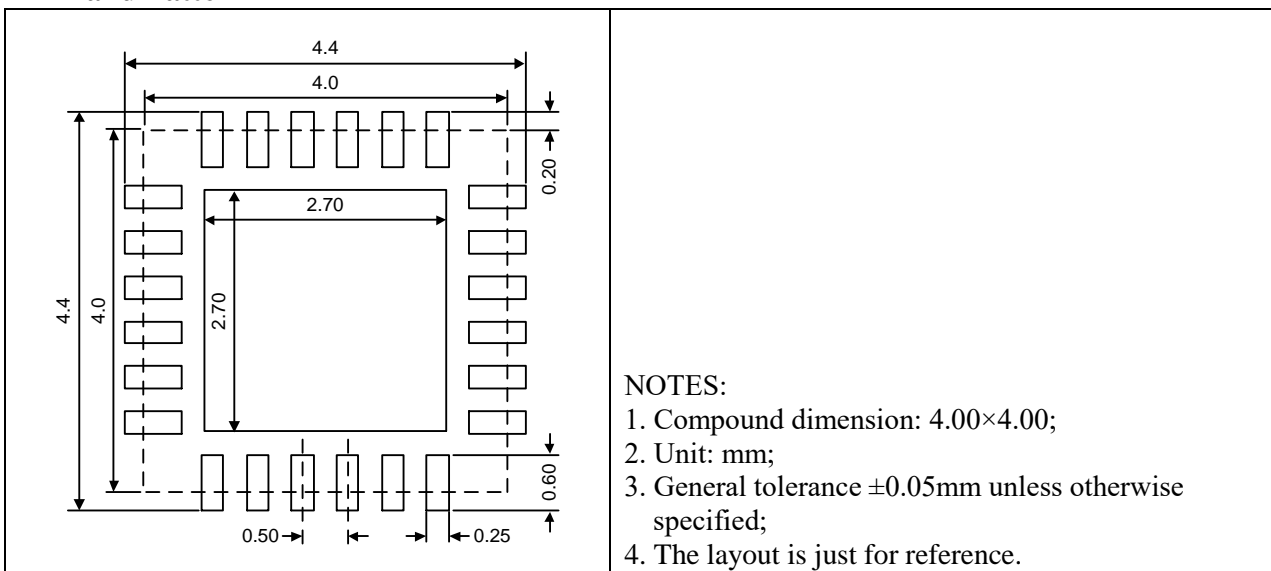
## Package Information

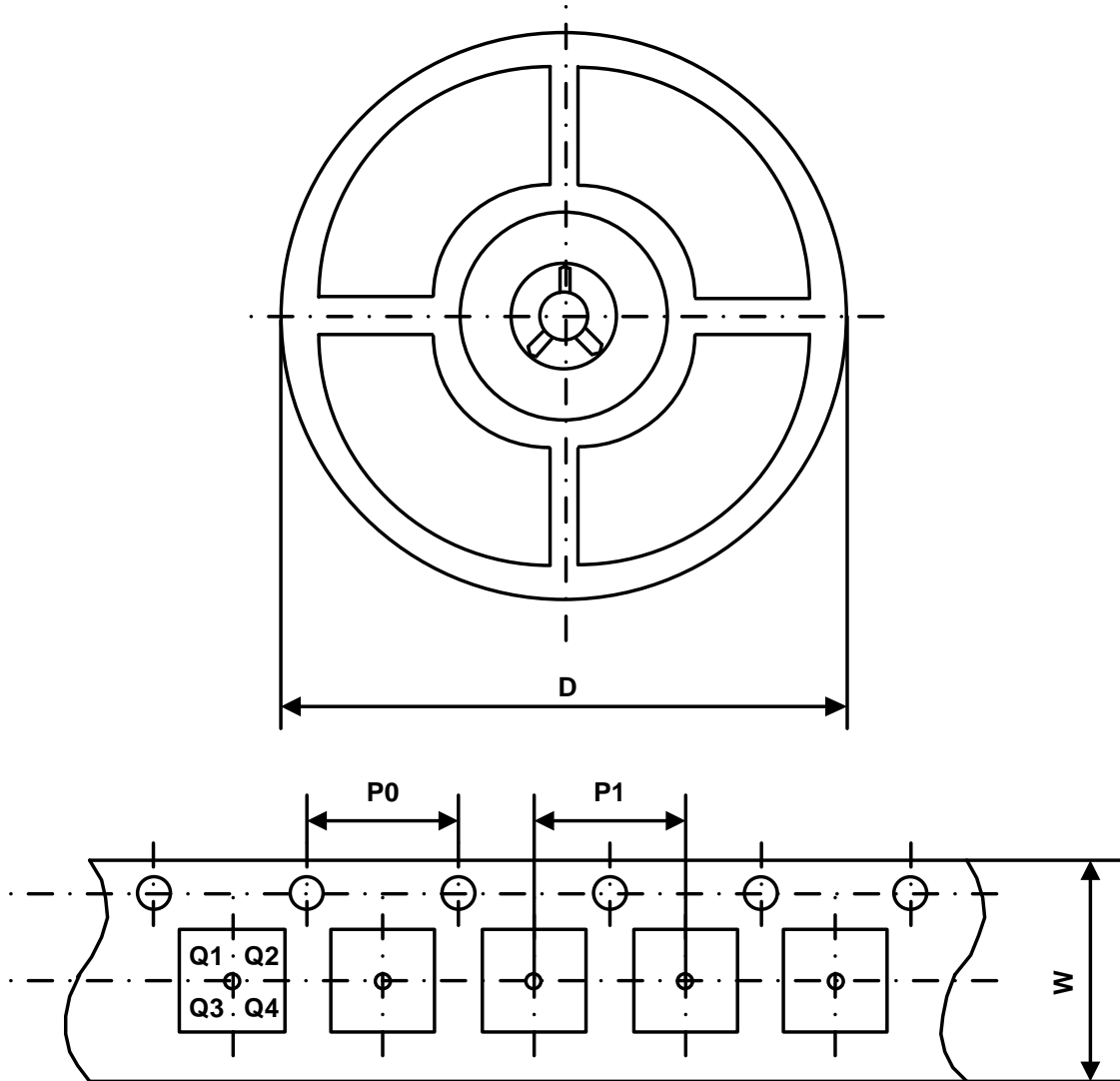
### QFN24 4.0×4.0

#### Outline Drawing



#### Land Pattern



**Packing Information**


Part Number	Package Type	Carrier Width (W)	Pitch (P0)	Pitch (P1)	Reel Size (D)	PIN 1 Quadrant
UM3011QCO	QFN24 4.0×4.0	12 mm	4 mm	8 mm	330 mm	Q1

---

## **GREEN COMPLIANCE**

Union Semiconductor is committed to environmental excellence in all aspects of its operations including meeting or exceeding regulatory requirements with respect to the use of hazardous substances. Numerous successful programs have been implemented to reduce the use of hazardous substances and/or emissions.

All Union components are compliant with the RoHS directive, which helps to support customers in their compliance with environmental directives. For more green compliance information, please visit:

<https://www.union-ic.com/Quality.html>

## **IMPORTANT NOTICE**

The information in this document has been carefully reviewed and is believed to be accurate. Nonetheless, this document is subject to change without notice. Union assumes no responsibility for any inaccuracies that may be contained in this document, and makes no commitment to update or to keep current the contained information, or to notify a person or organization of any update. Union reserves the right to make changes, at any time, in order to improve reliability, function or design and to attempt to supply the best product possible.