

High ESD-Protected, Single Supply RS-232 Transceivers

UM202EESE SOP16
UM202EEPE DIP16
UM202EEUE TSSOP16

General Description

The UM202EExE series are low power single supply RS232 interface. The device consists of two line drivers, two line receivers, and dual charge pump circuit. The device meets the requirements of TIA/EIA-232 standard and provides the electrical interface between an asynchronous communication controller and the serial-port connector. The on chip charge pump and four small external capacitors act as onboard DC to DC converter, allow chip operated from single 5V supply, eliminating the need for $\pm 10V$ power supplies, reduce cost and board space. The device operates at data signaling rates over 250Kbps. The slew rate of driver is set internally less than $30V/\mu s$ and the receivers feature internal noise filtering, eliminating the need for external slew rate and filter capacitors for reliable operation. The driver inputs and receiver outputs are TTL and CMOS compatible. UM202EExE comes in 16 pin DIP, SOP and TSSOP packages, operating over the commercial and industrial temperature ranges.

The ESD tolerance has been upgraded on these devices to $\pm 8kV$ for Human Body Model and $\pm 15kV$ IEC61000-4-2 Air Discharge Method, without latch-up. The device operates with four $0.1\mu F$ capacitors, reduce system cost and board space.

Applications

- Notebook and Palmtop Computers
- Battery-Powered Equipment
- Hand-Held Equipment
- POS Terminal

Features

- ESD Protection for RS-232 Bus Pins up to $\pm 8kV$ Human Body Model
- Single +5V Power Supply
- Low Power, I_{CC} 15mA Maximum
- Operates up to 250kbps
- Receiver Noise Filter
- Latch-Up Performance Exceeds 200mA

Ordering Information

Part Number	Temp. Range	Marking Code	Package Type	Shipping Qty
UM202EESE	-40 °C to +85 °C	UM202EESE	SOP16	2500pcs/13 Inch Tape & Reel
UM202EEPE	-40 °C to +85 °C	UM202EEPE	DIP16	25pcs/Tube
UM202EEUE	-40 °C to +85 °C	UM202EEUE	TSSOP16	3000pcs/13 Inch Tape & Reel

Pin Configurations

Top View

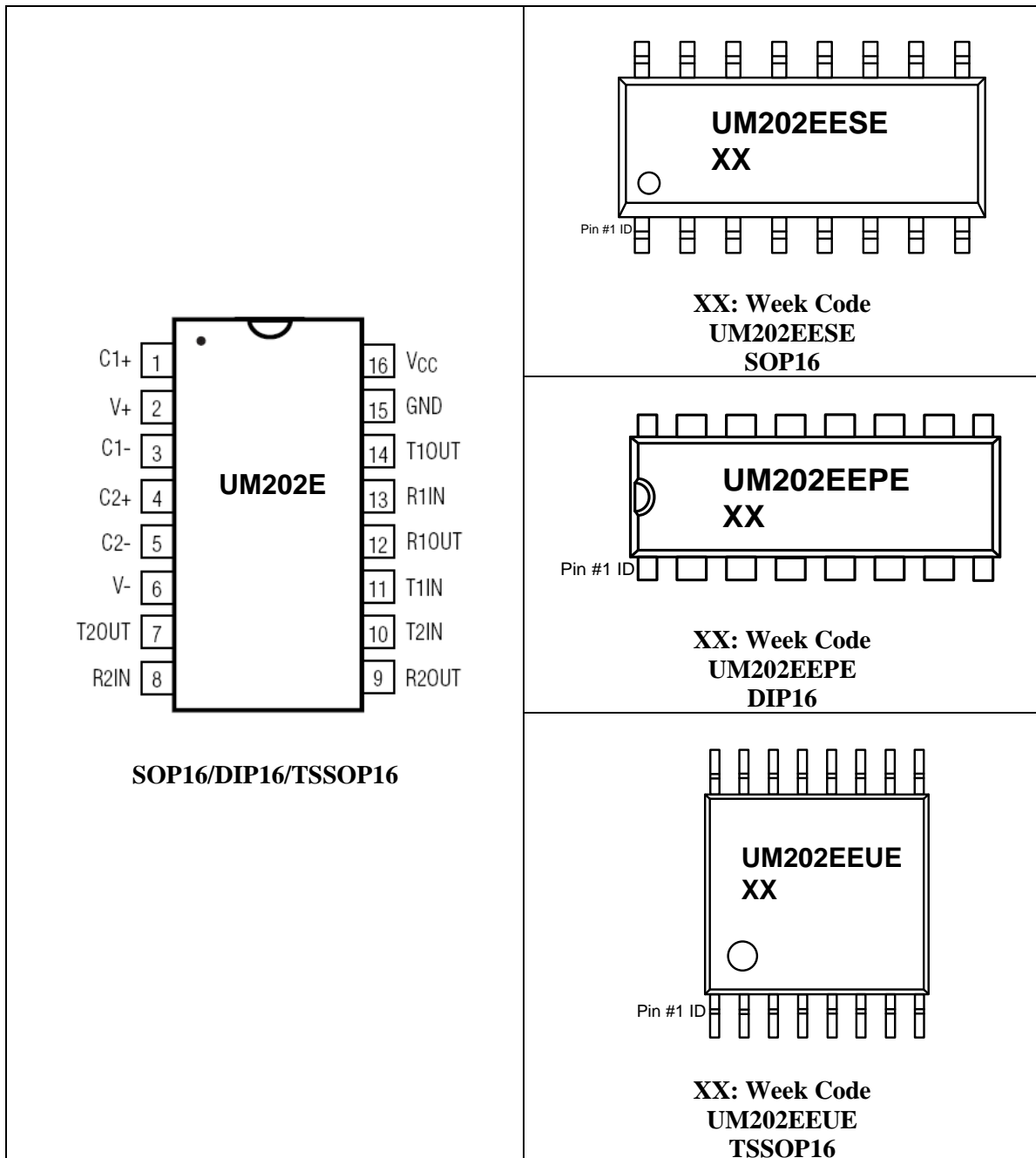

Pin Descriptions

Pin No. SOP/DIP/TSSOP	Pin Name	Function
1,3	C1+, C1-	Terminals for Positive Charge Pump Capacitor
2	V+	+2V _{CC} Voltage Generated by the Charge Pump
4,5	C2+, C2-	Terminals for Negative Charge Pump Capacitor
6	V-	-2V _{CC} Voltage Generated by the Charge Pump
7,14	T_OUT	RS-232 Driver Outputs
8,13	R_IN	RS-232 Receiver Inputs
9,12	R_OUT	RS-232 Receiver Outputs
10,11	T_IN	RS-232 Driver Inputs
15	GND	Ground
16	V _{CC}	+4.5V to +5.5V Supply Voltage Input

Absolute Maximum Ratings (Note 1)

Symbol	Parameter	Value	Unit	
V _{CC}	Supply Voltage on V _{CC}	-0.3 to +6	V	
V ₊	Voltage on V ₊	(V _{CC} -0.3) to +14	V	
V ₋	Voltage on V ₋	-14 to +0.3	V	
T_IN	Voltage on T_IN	-0.3 to (V _{CC} +0.3)	V	
R_IN	Voltage on R_IN	±30	V	
T_OUT	Voltage on T_OUT	(V ₋ -0.3) to (V ₊ +0.3)	V	
R_OUT	Voltage on R_OUT	-0.3 to (V _{CC} +0.3)	V	
	Short-Circuit Duration, T_OUT	Continuous		
P _D	Continuous Power Dissipation at T _A =70 °C	SOP16	696	mW
		DIP16	842	
		TSSOP16	754.7	
T _A	Operating Temperature Range	-40 to +85	°C	
T _{STG}	Storage Temperature Range	-65 to +165	°C	
T _L	Maximum Lead Temperature for Soldering 10 Seconds	+300	°C	

Note 1: Stresses beyond those listed under “Absolute Maximum Ratings” may cause permanent damage to the device. These are stress ratings only, and functional operation of the device at these or any other conditions beyond those indicated in the operational sections of the specifications is not implied. Exposure to absolute maximum rating conditions for extended periods may affect device reliability.

Electrical Characteristics

($V_{CC}=+5V \pm 10\%$, $C1- C4=0.1\mu F$, $T_A=T_{MIN}$ to T_{MAX} , unless otherwise noted. Typical values are at $T_A=25^\circ C$)

Parameter	Symbol	Conditions	Min	Typ	Max	Unit	
DC CHARACTERISTICS							
V_{CC} Supply Current	I_{CC}	No Load, $T_A=+25^\circ C$		10	15	mA	
LOGIC							
Input Leakage Current		$T_{IN}=0V$ to V_{CC}			± 10	μA	
Input Threshold Low	V_{IL}	T_{IN}			0.8	V	
Input Threshold High	V_{IH}	T_{IN}	2.0			V	
Output Voltage Low	V_{OL}	R_{OUT} ; $I_{OUT}=3.2mA$			0.4	V	
Output Voltage High	V_{OH}	R_{OUT} ; $I_{OUT}=-1.0mA$	3.5	$V_{CC}-0.4$		V	
Output Leakage Current		$0V \leq R_{OUT} \leq V_{CC}$		± 0.05	± 10	μA	
EIA/TIA-232E RECEIVER INPUTS							
Input Voltage Range			-30		30	V	
Input Threshold Low		$T_A=+25^\circ C$, $V_{CC}=5V$	Normal Operation	0.8	1.2	V	
Input Threshold High		$T_A=+25^\circ C$, $V_{CC}=5V$	Normal Operation		1.7	2.4	V
Input Hysteresis		$V_{CC}=5V$	0.2	0.5	1.0	V	
Input Resistance		$T_A=+25^\circ C$, $V_{CC}=5V$	3	5	7	k Ω	
EIA/TIA-232E TRANSMITTER OUTPUTS							
Output Voltage Swing		All Drivers Loaded with 3k Ω to Ground	± 5	± 9		V	
Output Resistance		$V_{CC}=V+=V-=0V$, $V_{OUT}=\pm 2V$	300			Ω	
Output Short-Circuit Current		Short to V_{CC} , GND or Other TXD Pin			± 70	mA	
TIMING CHARACTERISTICS							
Maximum Data Rate		$R_L=3k\Omega$ to $7k\Omega$, $C_L=50pF$ to $1000pF$, One Transmitter Switching	250			kbps	
Receiver Propagation Delay	t_{PLHR} , t_{PHLR}	$C_L=150pF$	All Parts, Normal Operation	0.3		μs	
Transmitter Propagation Delay	t_{PLHT} , t_{PHLT}	$R_L=3k\Omega$, $C_L=2500pF$, All Transmitters Loaded		1.2		μs	
Transition-Region Slew Rate		$T_A=+25^\circ C$, $V_{CC}=5V$, $R_L=3k\Omega$ to $7k\Omega$, $C_L=50pF$ to $1000pF$, Measured from $-3V$ to $+3V$ or $+3V$ to $-3V$, Figure 1		20	30	V/ μs	
ESD PERFORMANCE							
TRANSMITTER OUTPUTS, RECEIVER INPUTS							
ESD-Protection Voltage		Human Body Model		± 8		kV	
		IEC61000-4-2, Contact Discharge		± 8			
		IEC61000-4-2, Air-Gap Discharge		± 15			

Detailed Description

The UM202EExE consists of three sections: charge-pump voltage converters, drivers, and receivers. These E versions provide extra protection against ESD. They survive $\pm 8\text{kV}$ discharges to the RS-232 inputs and outputs, tested using the Human Body Model. When tested according to IEC61000-4-2, they survive $\pm 8\text{kV}$ contact-discharges and $\pm 15\text{kV}$ air-gap discharges. The rugged E versions are intended for use in harsh environments or applications where the RS-232 connection is frequently changed. The UM202EExE devices have internal charge pump voltage converters which allow them to operate from a single +5V supply. The charge pumps will operate with polarized or non-polarized capacitors ranging from 0.1 to $10\mu\text{F}$ and will generate the $\pm 9\text{V}$ needed to generate the RS-232 output levels.

RS-232 Drivers

The drivers are inverting transmitters, which accept TTL or CMOS inputs and output RS-232 signals with an inverted sense relative to the input logic levels. Typically the RS-232 output voltage swing is $\pm 9\text{V}$. Even under worst case loading conditions of $3\text{k}\Omega$ and 2500pF , the output is guaranteed to be $\pm 5\text{V}$, which is consistent with the RS-232 standard specifications. The transmitter outputs are protected against infinite short-circuits to ground without degradation in reliability. The instantaneous slew rate of the transmitter output is internally limited to a maximum of $30\text{V}/\mu\text{s}$ in order to meet the RS-232 standard. The smooth transition of the loaded output from V_{OL} to V_{OH} clearly meets the monotonicity requirements of the RS-232 standard.

RS-232 Receivers

The receivers convert RS-232 input signals to inverted TTL signals. The input thresholds are 0.8V minimum and 2.4V maximum, again well within the 3V RS-232 requirements. The receiver inputs are also protected against voltage up to 30V. A $5\text{k}\Omega$ pull down resistor to ground will commit the output of the receiver to a high state when the pin is float. In actual system applications, it is quite possible for signals to be applied to the receiver inputs before power is applied the receiver circuitry. This occurs, for example, when a PC user attempts to print, only to realize the printer wasn't turned on. In this case an RS-232 signal from the PC will appear on the receiver input at the printer. When the printer power is turned on, the receiver will operate normally. All of these enhanced devices are fully protected.

ESD Protection

UM202EExE devices have standard ESD protection structures incorporated on the pins to protect against electrostatic discharges encountered during assembly and handling. In addition, the RS232 bus pins (driver outputs and receiver input) of these devices have an extra level of ESD protection. Advanced ESD structures were designed to successfully protect these pins against ESD discharge of $\pm 8\text{kV}$ Human Body Model when powered down or up.

Test Circuits

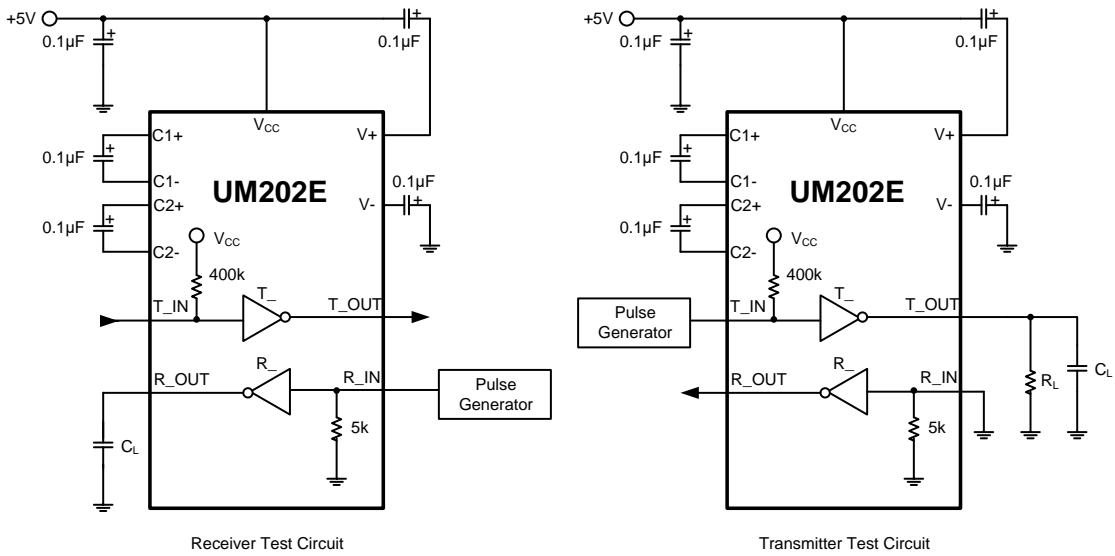

Receiver Test Circuit

Transmitter Test Circuit

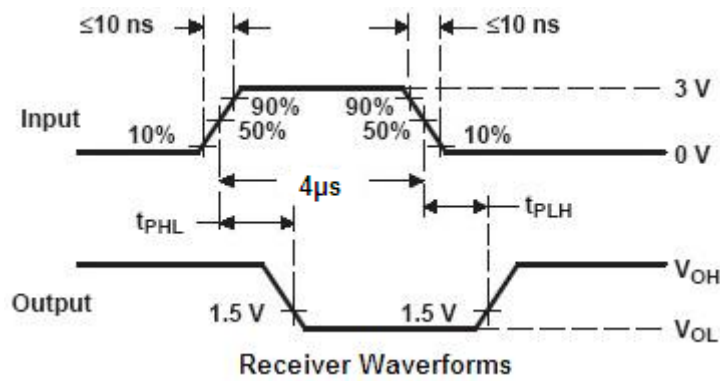

Receiver Waveforms

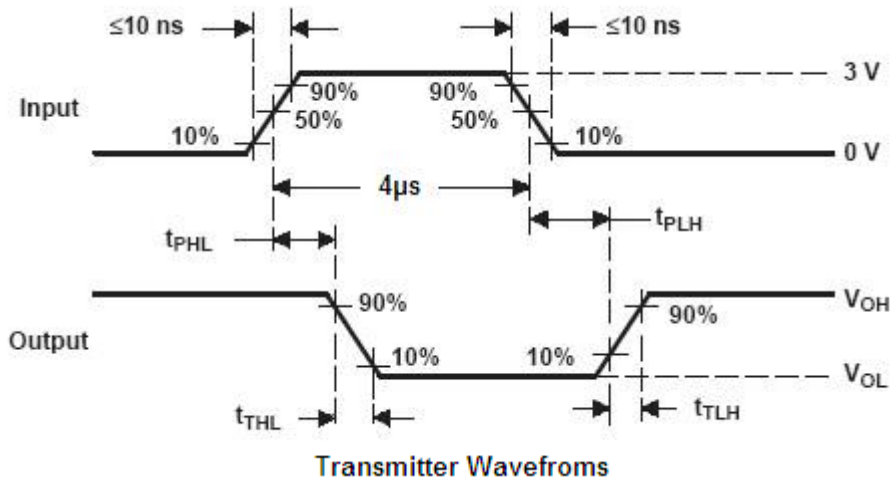

Transmitter Waveforms

Figure 1

Typical Operating Circuits

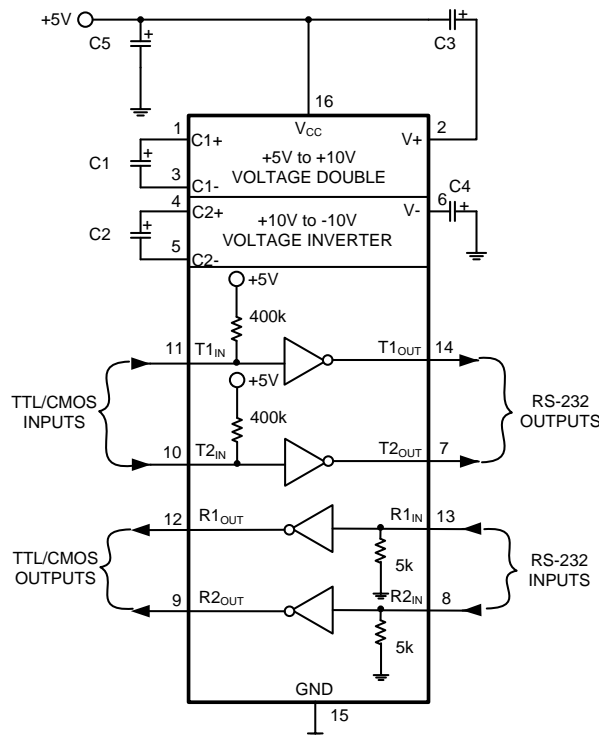

Figure 2

Applications Information

Capacitor Selection

The capacitor type used for C1–C4 is not critical for proper operation. The UM202EExE, require 0.1μF capacitors, although in all cases capacitors up to 10μF can be used without harm. Ceramic dielectrics are suggested for the 0.1μF capacitors. When using the minimum recommended capacitor values, make sure the capacitance value does not degrade excessively as the operating temperature varies. If in doubt, use capacitors with a larger (e.g., 2x) nominal value. The capacitors' effective series resistance (ESR), which usually rises at low temperatures, influences the amount of ripple on V₊ and V₋. Use larger capacitors (up to 10μF) to reduce the output impedance at V₊ and V₋. Bypass V_{CC} to ground with at least 0.1μF capacitor. In applications sensitive to power-supply noise generated by the charge pumps, decouple V_{CC} to ground with a capacitor the same size as (or larger than) the charge pump capacitors (C1–C4).

V₊ and V₋ as Power Supplies

A small amount of power can be drawn from V₊ and V₋, although this will reduce both driver output swing and noise margins. Increasing the value of the charge-pump capacitors (up to 10μF) helps maintain performance when power is drawn from V₊ or V₋.

Driving Multiple Receivers

Each transmitter is designed to drive a single receiver. Transmitters can be paralleled to drive multiple receivers.

High Data Rates

These transceivers maintain the RS-232 ±5.0V minimum driver output voltages at data rates of over 250 kbps.

Package Information

UM202EESE SOP16

Outline Drawing

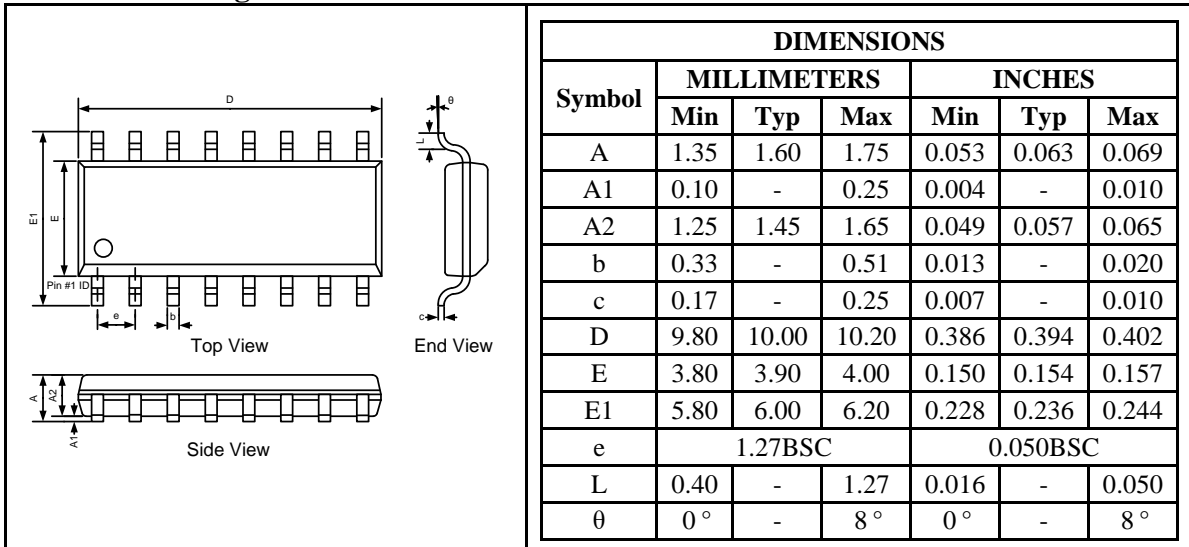

Land Pattern

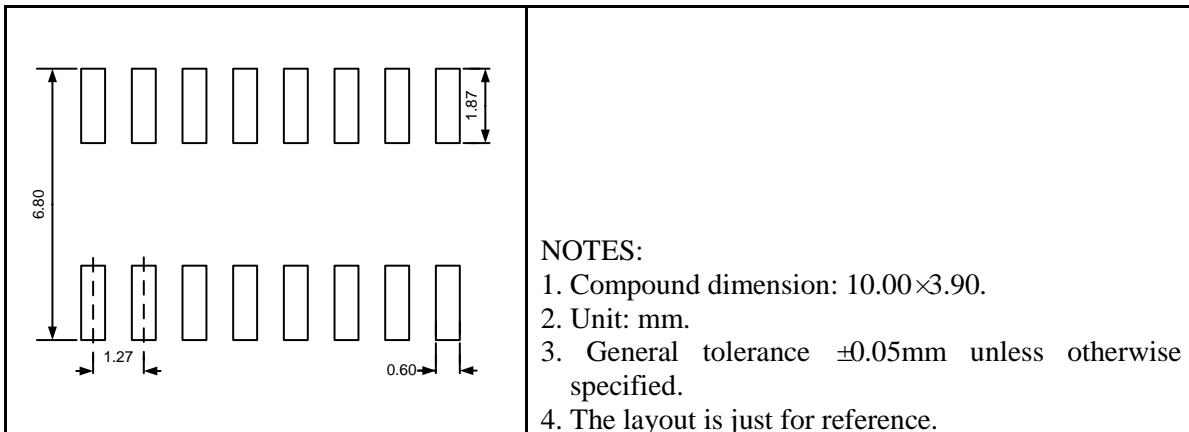

Tape and Reel Orientation



UM202EEPE DIP16

Outline Drawing

DIMENSIONS						
Symbol	MILLIMETERS			INCHES		
	Min	Typ	Max	Min	Typ	Max
A	3.71	4.01	4.31	0.146	0.158	0.170
A1	0.51	-	-	0.020	-	-
A2	3.20	3.40	3.60	0.126	0.134	0.142
b	0.38	0.48	0.57	0.015	0.019	0.022
b1	1.52BSC			0.060BSC		
c	0.20	0.28	0.36	0.008	0.011	0.014
D	18.80	19.00	19.20	0.740	0.748	0.756
E	6.20	6.40	6.60	0.244	0.252	0.260
E1	7.32	7.62	7.92	0.288	0.300	0.312
E2	8.40	8.70	9.00	0.331	0.343	0.354
e	2.54BSC			0.100BSC		
L	3.00	3.30	3.60	0.118	0.130	0.142

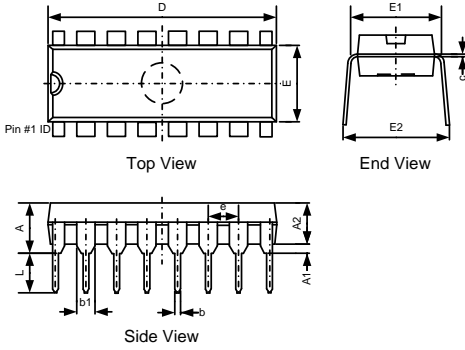

UM202EEUE TSSOP16

Outline Drawing

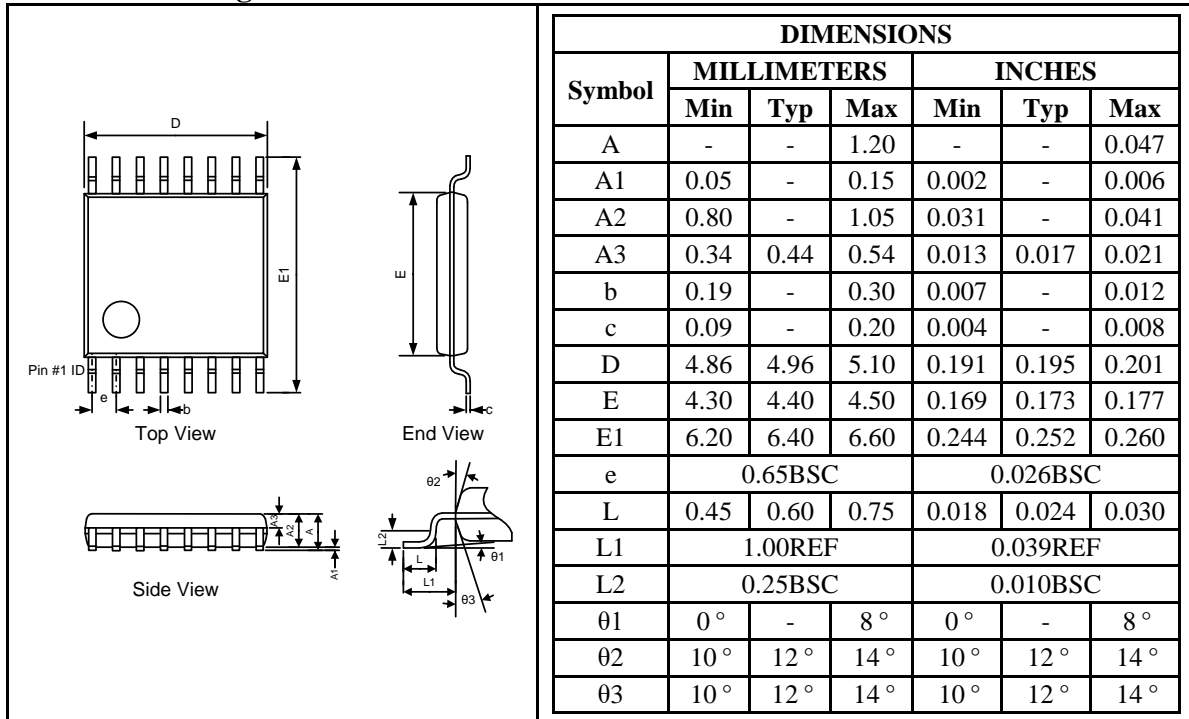

Land Pattern

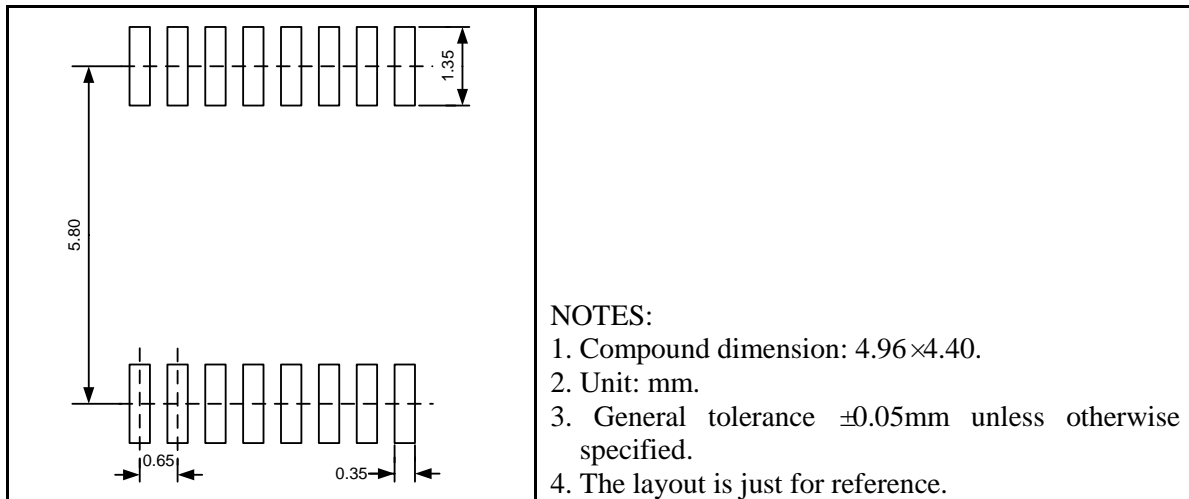

Tape and Reel Orientation



Packing Information

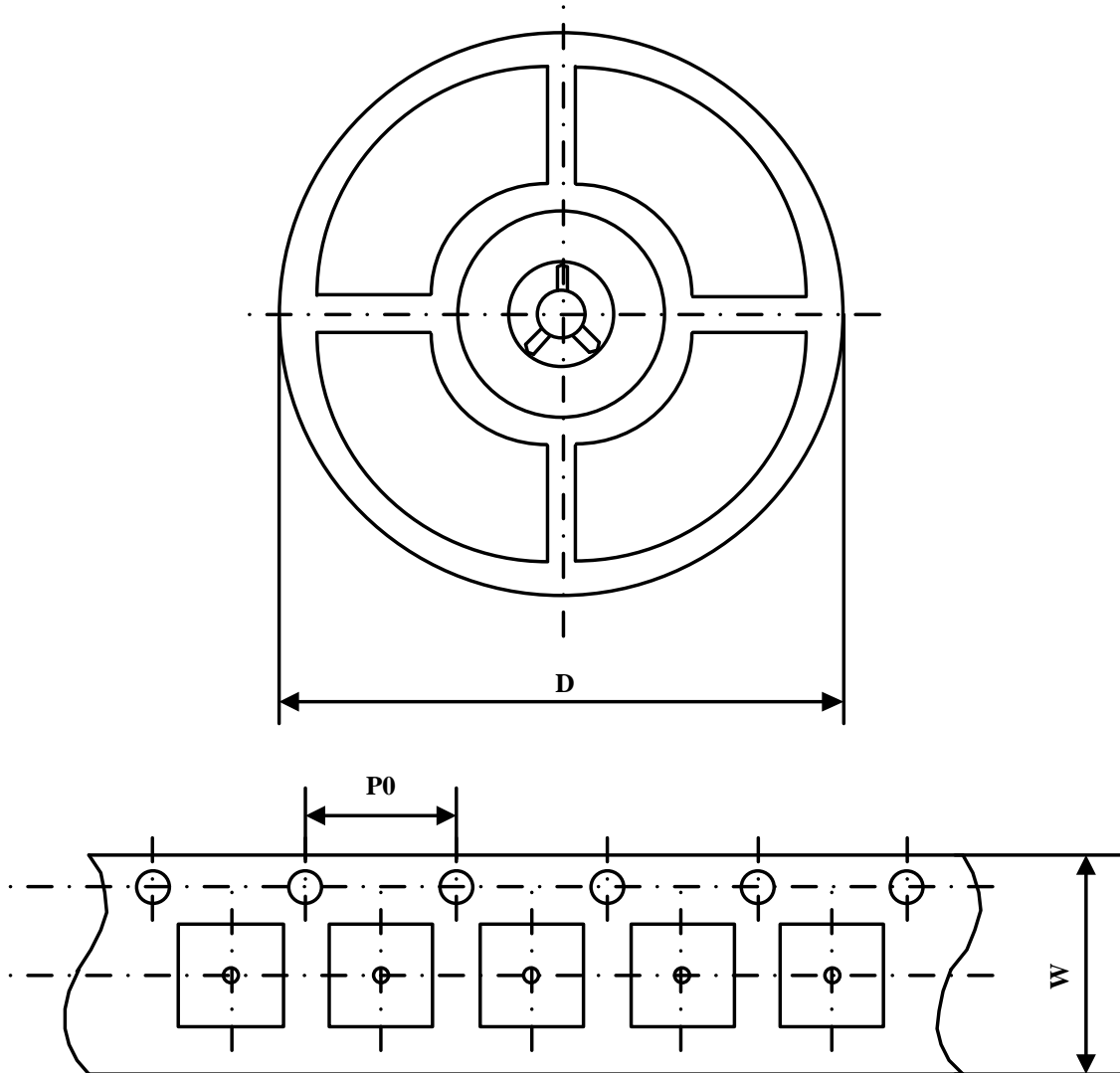

Part Number	Package Type	Carrier Width(W)	Pitch(P0)	Reel Size(D)
UM202EESE	SOP16	16 mm	4 mm	330 mm
UM202EEUE	TSSOP16	16 mm	4 mm	330 mm

GREEN COMPLIANCE

Union Semiconductor is committed to environmental excellence in all aspects of its operations including meeting or exceeding regulatory requirements with respect to the use of hazardous substances. Numerous successful programs have been implemented to reduce the use of hazardous substances and/or emissions.

All Union components are compliant with the RoHS directive, which helps to support customers in their compliance with environmental directives. For more green compliance information, please visit:

http://www.union-ic.com/index.aspx?cat_code=RoHSDeclaration

IMPORTANT NOTICE

The information in this document has been carefully reviewed and is believed to be accurate. Nonetheless, this document is subject to change without notice. Union assumes no responsibility for any inaccuracies that may be contained in this document, and makes no commitment to update or to keep current the contained information, or to notify a person or organization of any update. Union reserves the right to make changes, at any time, in order to improve reliability, function or design and to attempt to supply the best product possible.