



UNION SEMICONDUCTOR

www.union-ic.com

Product Selection Guide

Company Profile

Who We Are

Founded in 2001, Union Semiconductor is a fabless integrated circuit design company, engaged in inventing, designing and marketing high performance linear and mixed-signal integrated circuits (ICs) for use in a variety of electronic equipment.

Union Semiconductor's products bridge the analog real world and digital world by detecting, measuring, amplifying, converting power supply and providing protection for electronic circuits.

Corporate Mission

Union Semiconductor's mission is to continuously develop high quality and innovative mixed signal IC solutions that add value to customers' electronics equipment worldwide.

Products and Applications

Our products include power supplies, power management circuits, analog switches, interface circuits, ESD protection ICs and EMI filters.

Union Semiconductor markets over 250 analog ICs for uses in a wide variety of electronic equipment. These include PCs and their peripherals, portable devices, instrumentation, test equipments and digital consumer electronics.

Contact Us

Union Semiconductor, Incorporated.

Add: Room 606, No. 570 Shengxia Road, Zhangjiang Hi-Tech Park, Shanghai

Zip Code: 201210

Tel: 86-21-51093966

Fax: 86-21-51026018

Website: www.union-ic.com

Union Semiconductor Product Lines

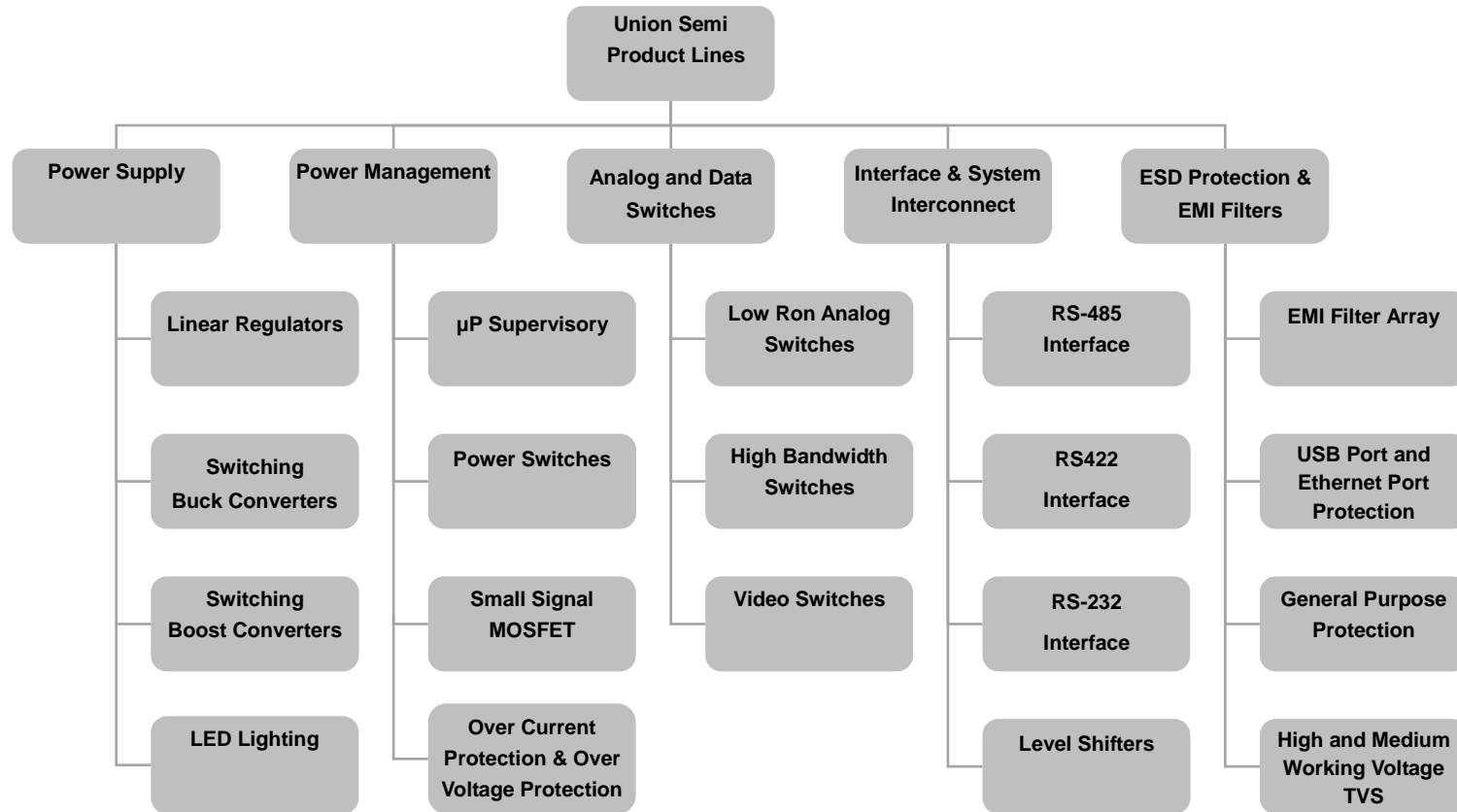

Smart Phone Solution

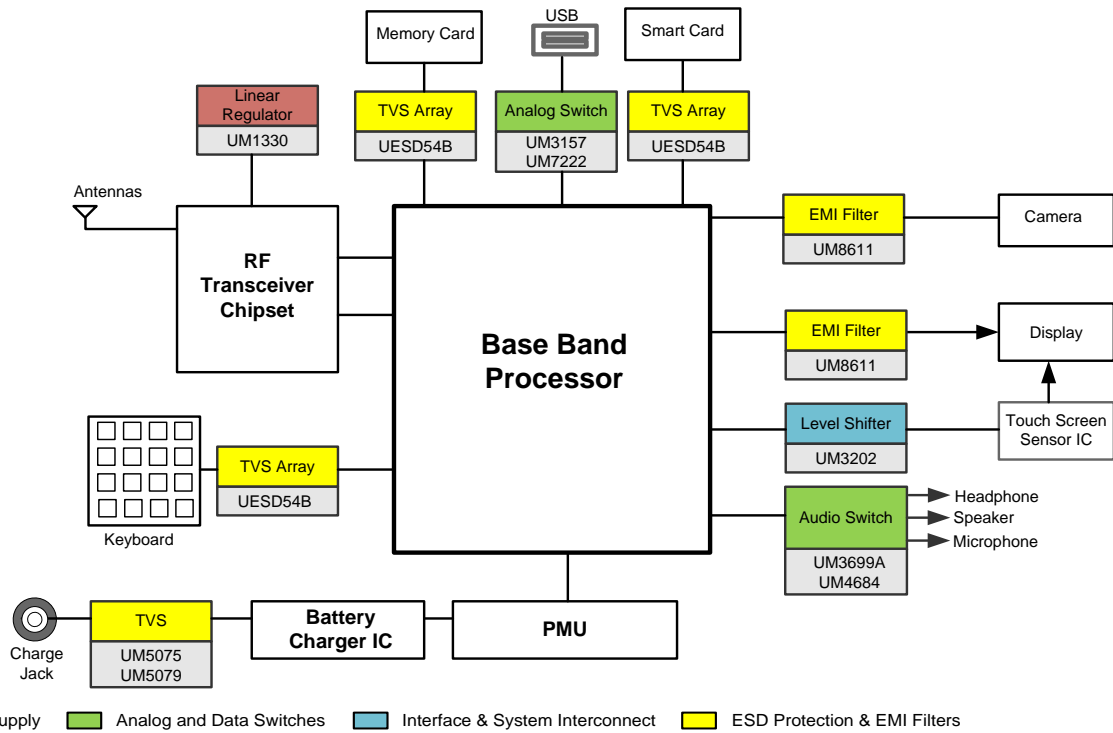

Tablet Solution

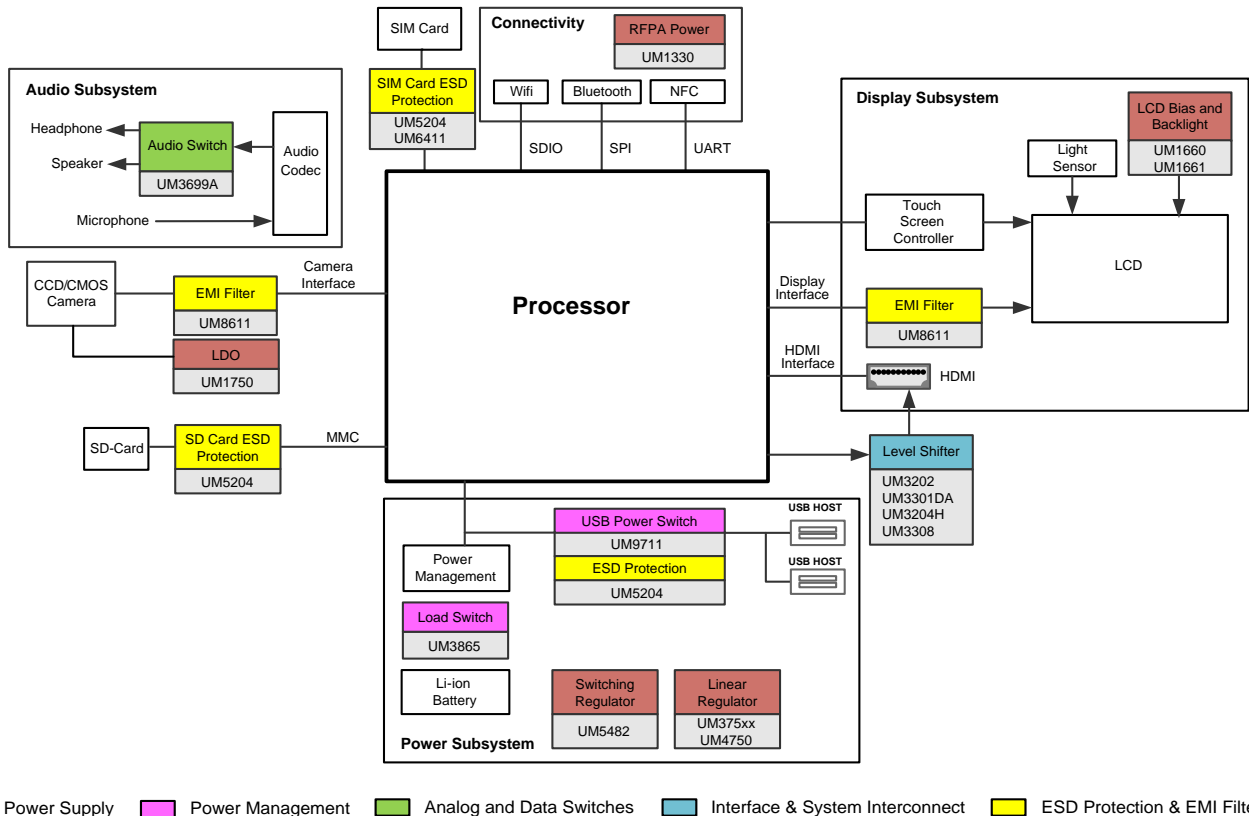

Point of Sales Terminal Solution

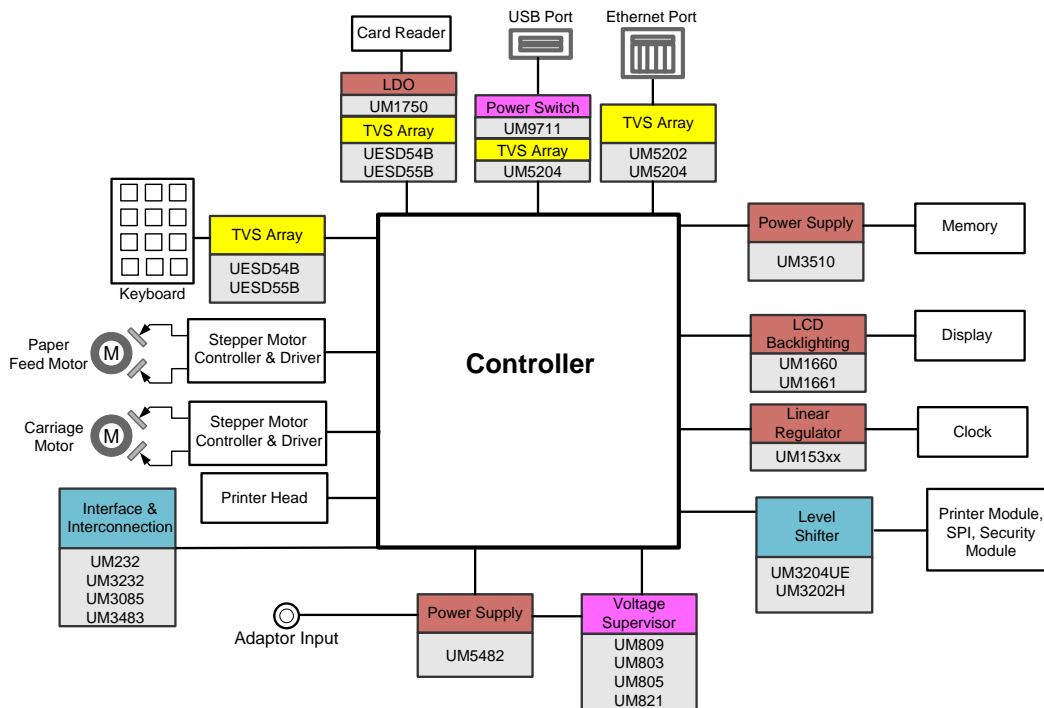

■ Power Supply
 ■ Power Management
 ■ Interface & System Interconnect
 ■ ESD Protection & EMI Filters

Set-Top Box Solution

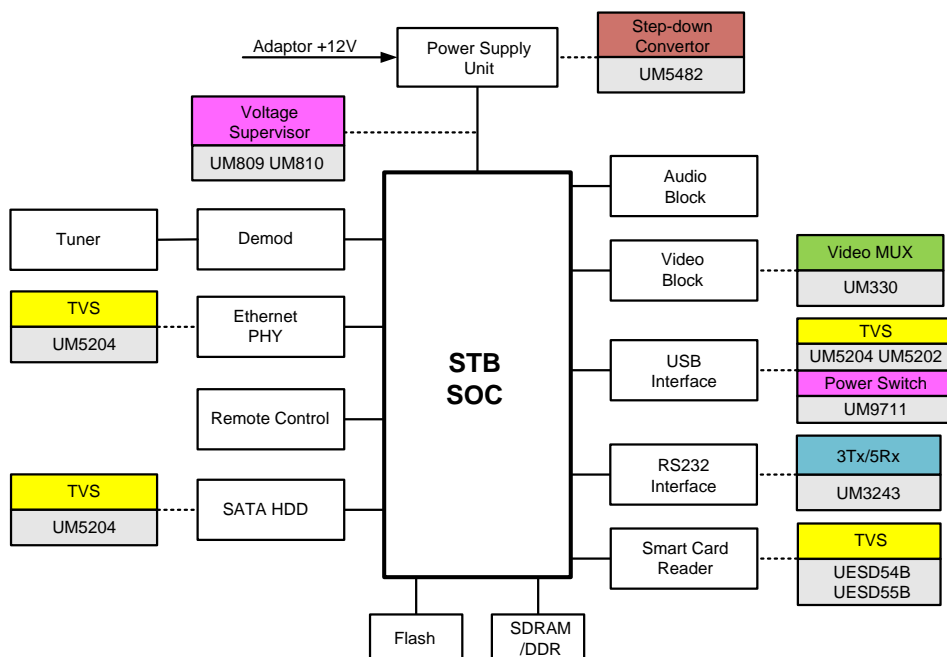

■ Power Supply
 ■ Power Management
 ■ Analog and Data Switches
 ■ Interface & System Interconnect
 ■ ESD Protection & EMI Filters

Wearable Product Solution

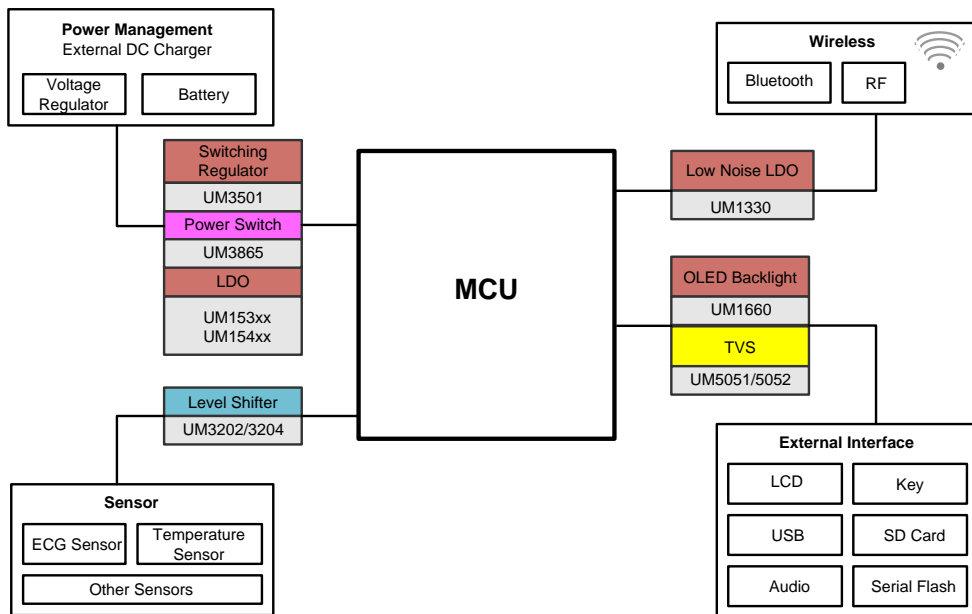

■ Power Supply
 ■ Power Management
 ■ Interface & System Interconnect
 ■ ESD Protection & EMI Filters

Security and Surveillance Solution

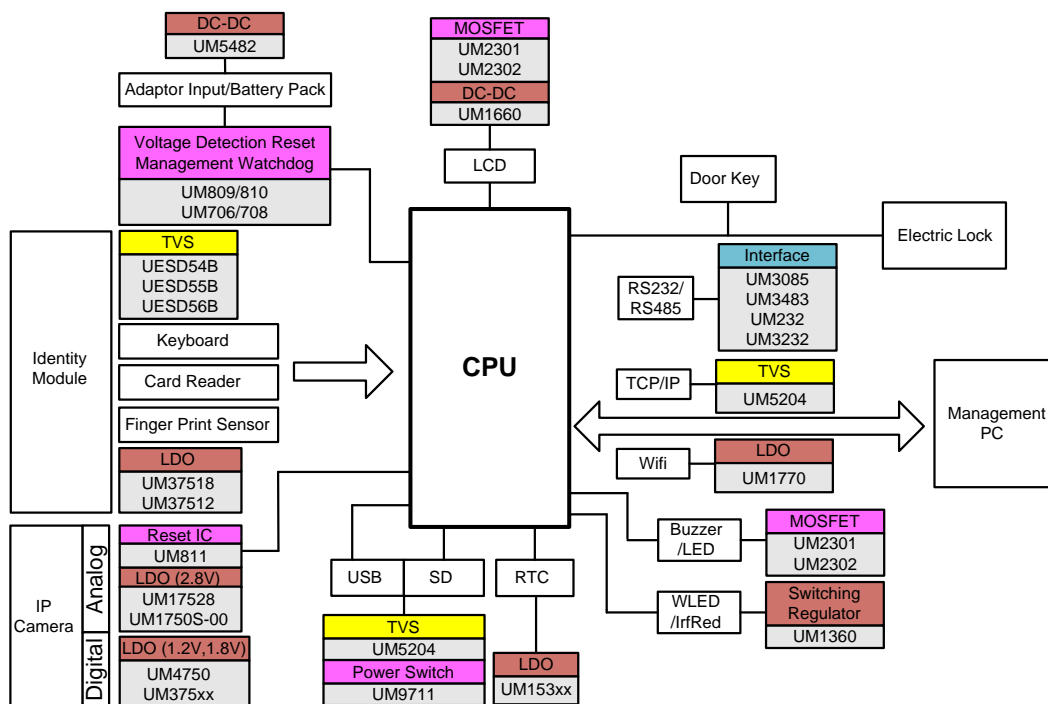

■ Power Supply
 ■ Power Management
 ■ Interface & System Interconnect
 ■ ESD Protection & EMI Filters

Smart Grid Solution

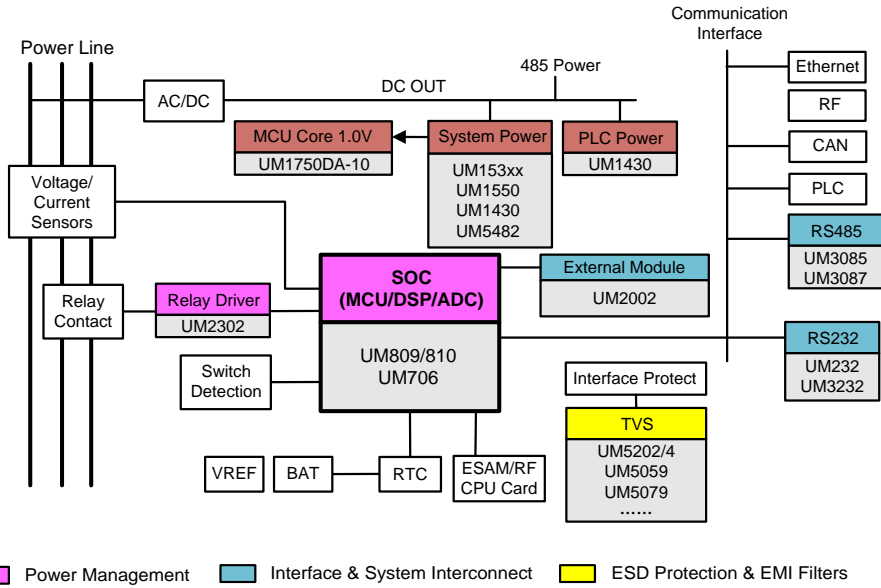

ADSL Modem Solution

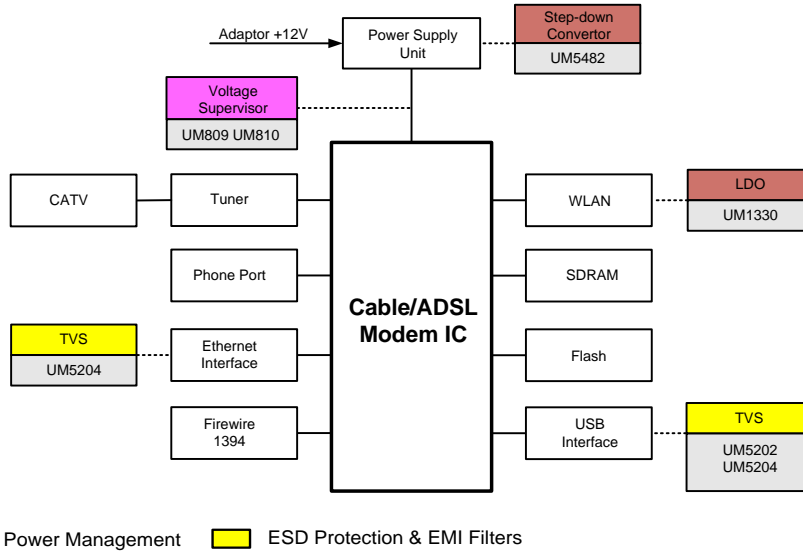

Braswell Solution

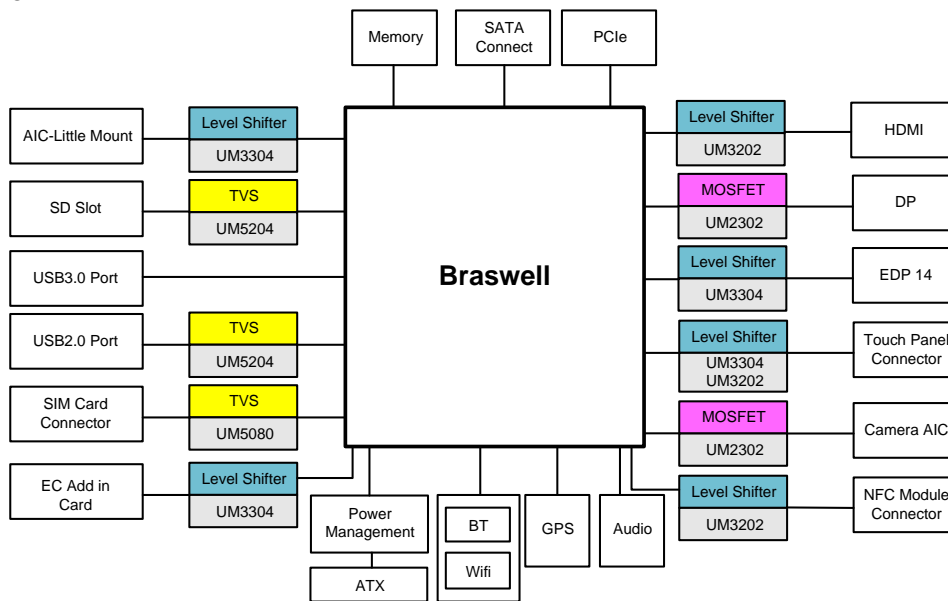

Bay Trail-T for Tablet Solution

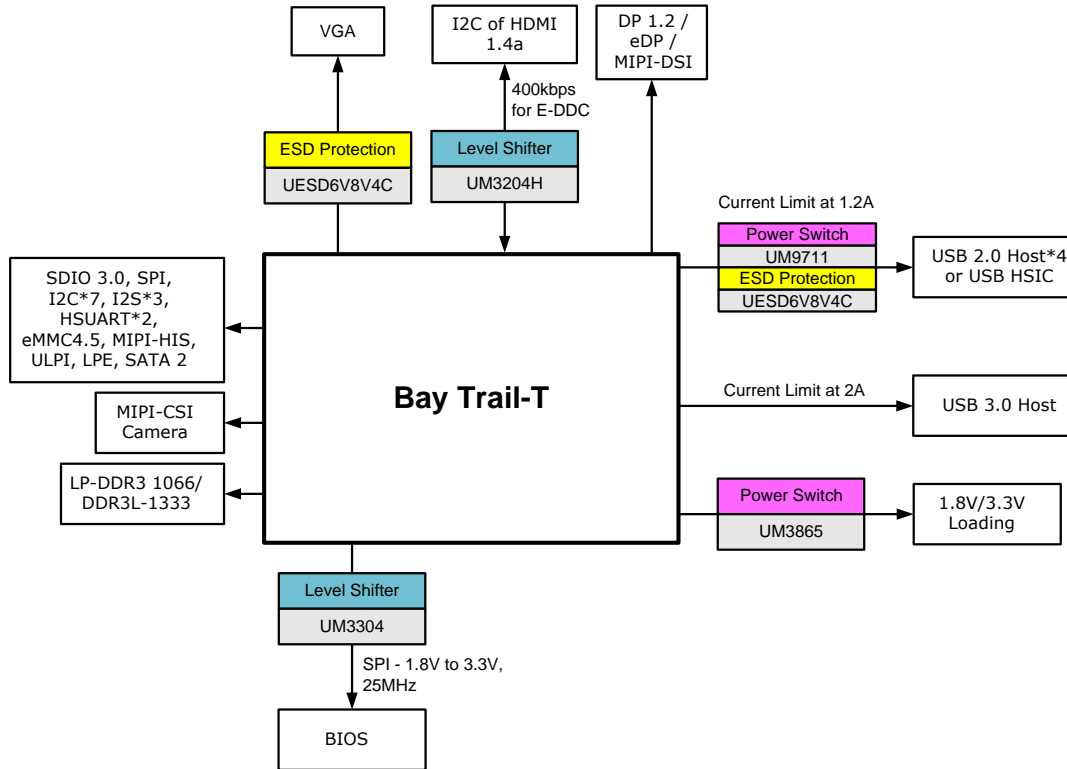

■ Power Management
 ■ Interface & System Interconnect
 ■ ESD Protection & EMI Filters

Bay Trail-M for Notebook Solution

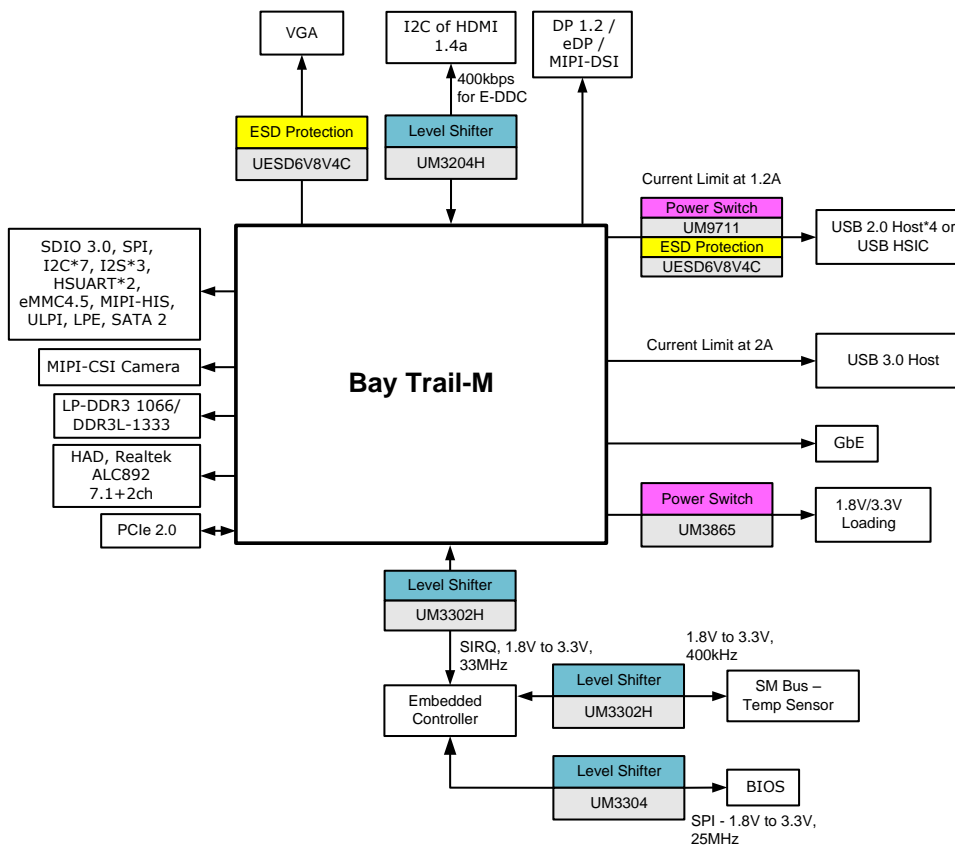

■ Power Management
 ■ Interface & System Interconnect
 ■ ESD Protection & EMI Filters

Bay Trail-D for Desktop Solution

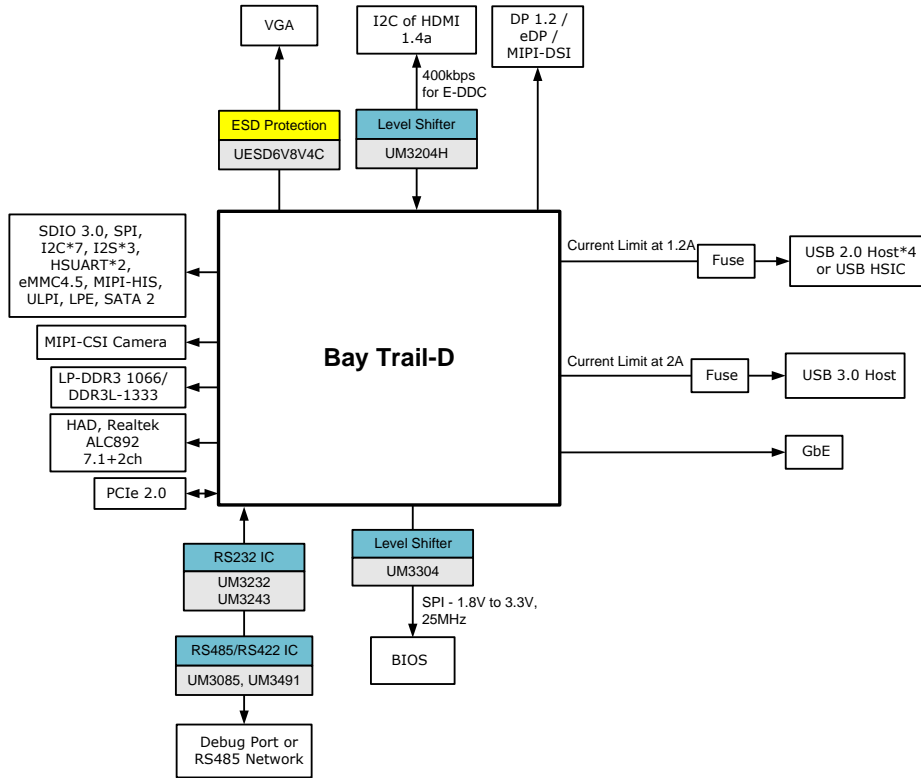

■ Interface & System Interconnect
 ■ ESD Protection & EMI Filters

Bay Trail-I for Industrial Solution

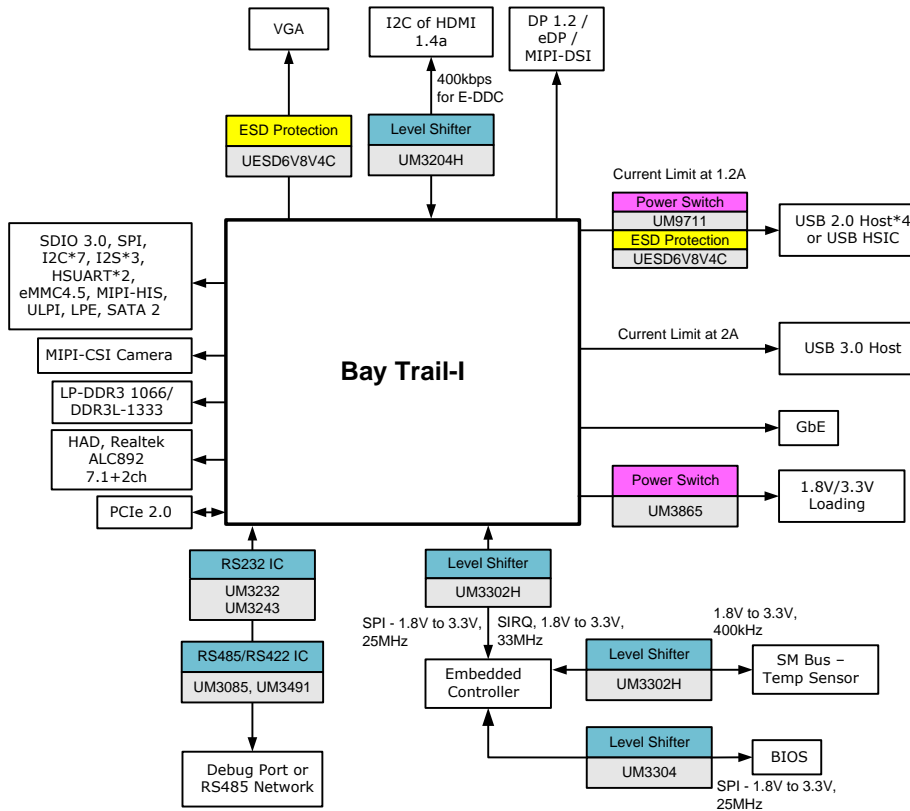

■ Power Management
 ■ Interface & System Interconnect
 ■ ESD Protection & EMI Filters

Table of Contents

Power Supply

Linear Regulators	2-5
Single Channel $\leq 350\text{mA}$ Output Current LDOs	2
Dual Channel 300mA Output Current LDOs	2
Single Channel 500mA Output Current LDOs	2
High Input Voltage LDOs	2
Ultra Low Quiescent Current LDOs	2
Low Output Noise LDOs	2
Switching Regulators	6-9
DC-DC Buck Converters	6
DC-DC Boost Converters	6
LED Backlight Boost Drivers	6
LED Lighting Buck Drivers	6

Power Management

μP Supervisory	10
Small Signal MOSFET	10
Power Switches	10

Analog and Data Switches

Low Ron Analog Switches	13
High Bandwidth Data Switches	13
Video Switches	13

Interface and System Interconnect

RS485 Interface	15
RS422 Interface	15
RS232 Interface	15
Level Shifters	16

ESD Protection and EMI Filters

EMI Filter Array	20
USB Port and Ethernet Port Protection	21
General Purpose Protection	21
High and Medium Working Voltage Transient Voltage Suppressors (TVS)	22

Appendix

Sales Contact	24
---------------------	----

Product Selection Guide

Linear Regulators (LDOs)

Part Number	Features	V _{IN} (V) (Min)	V _{IN} (V) (Max)	V _{OUT} (V)	I _{OUT} (mA) (Max)	I _Q (μA) @ V _{IN_MAX} (Typ)	V _{DROP} (mV) @ I _{OUT} (Max) <i>Note2</i>	Package
300mA/350mA CMOS Linear Regulators without EN Control								
UM165xx	Ultra Low Dropout, Input Under Voltage Lockout	2.5	6.0	2.8/3.3 <i>Note1</i>	300	120	90 @ 150mA	SOT23-3
UM365xx	Standard Low Dropout	2.5	6.0	1.2V to 5.0V with 0.1V Interval	300	55	200 @ 100mA	SOT23-3 SOT323
UM1650S-xx	350mA, Ultra Low Dropout, Input Under Voltage Lockout	2.5	6.0	Fixed 1.0V to 4.0V with 0.1V Interval	350	90	150 @ 150mA	SOT23-3
300mA/350mA CMOS Linear Regulators with EN Control								
UM175xx	Ultra Low Dropout, EN Control, Input Under Voltage Lockout	2.5	6.0	2.8/3.3 <i>Note1</i>	300	120	90 @ 150mA	SOT23-5
UM375xx	Standard Low Dropout EN Control	2.0	6.0	1.2V to 5.0V with 0.1V Interval	300	55	200 @ 100mA	SOT23-5 SOT353
UM1750	350mA, Ultra Low Dropout, Input Under Voltage Lockout, Excellent Load Transient	2.5	6.0	Fixed 1.0V to 4.0V with 0.1V Interval, or Adjustable Output from 1.0V to 5.0V	350	90	150 @ 150mA	DFN6 2.0x2.0 SOT89-5 SOT23-5
500mA CMOS Linear Regulator								
UM1770	500mA Output Current, Ultra Low Dropout, Input Under Voltage Lockout	2.5	6.0	Fixed 1.0V to 4.0V with 0.1V Interval, or Adjustable Output from 1.0V to 5.0V	500	120	450 @ 500mA	DFN6 2.0x2.0 SOT89-5
Dual Channel 300mA CMOS Linear Regulator								
UM4750	Dual Channel Separate EN Control	2.5	5.5	1.2/1.5/1.8/2.5/2.7/2.8/3.0/3.3 <i>Note1</i>	300	120	200 @ 100mA	SOT23-6 DFN8 3.0x3.0 DFN6 2.0x2.0
High Input Voltage Linear Regulators								
UM142xx	12V Input Voltage	2.5	12.0	2.5V to 5.0V with 0.1V Interval	300	9	300 @ 150mA	SOT23-3 SOT89-3
UM1430	18V Input Voltage	3.6	18.0	2.0V to 6.0V with 0.1V Interval	30	4.8	300 @ 30mA	SOT23-3 SOT23-5, SOT89-3
UM1440	18V Input Voltage with EN Control	3.6	18.0	2.0V to 6.0V with 0.1V Interval	30	4.8	300 @ 30mA	SOT23-5 SOT89-5
UM1431	30V Input Voltage	3.6	30.0	2.0V to 6.0V with 0.1V Interval	30	5.8	300 @ 30mA	SOT23-3 SOT23-5, SOT89-3
UM1441	30V Input Voltage with EN Control	3.6	30.0	2.0V to 6.0V with 0.1V Interval	30	5.8	300 @ 30mA	SOT23-5 SOT89-5
Ultra Low Quiescent Current Linear Regulators								
UM153xx	Ultra Low I _Q	2.2	5.5	1.3/1.5/1.8/2.5/2.8/3.0/3.3/3.5 <i>Note1</i>	200 @ V _{IN} ≥3.5V	0.8uA @ V _{IN} =3.0V	130 @ 30mA	SOT23-3, SOT89-3 DFN4 1.8x1.2
UM154xx	Ultra Low I _Q with EN Control	2.2	5.5	1.3/1.5/1.8/2.5/2.8/3.0/3.3/3.5 <i>Note1</i>	200 @ V _{IN} ≥3.5V	0.8uA @ V _{IN} =3.0V	130 @ 30mA	SOT23-5, SOT89-5 DFN6 2.0x2.0
UM1550	Wide Input Voltage Range, Ultra Low I _Q	1.8	8.0	1.2V to 5.0V with 0.1V Interval	250	1.4uA @ V _{IN} =5.0V	200 @ 100mA	DFN6 2.0x2.0 DFN4 1.0x1.0 SOT23-3, SOT89-3
UM1560	Wide Input Voltage Range, Ultra Low I _Q with EN Control	1.8	8.0	1.2V to 5.0V with 0.1V Interval	250	1.4uA @ V _{IN} =5.0V	200 @ 100mA	DFN6 2.0x2.0 DFN4 1.0x1.0 SOT23-5
Low Output Noise Linear Regulator								
*UM1330	250mA Output Current, 40μV _{RMS} Low Noise	1.8	8.0	1.2V to 5.0V with 0.1V Interval	250	10	140 @ 150mA	SOT23-5, SOT353 DFN4 1.0x1.0

Note1: Besides the standard output voltages listed in the table, customized output voltage is also available from 1.2V to 5.0V at step of 100mV. Contact factory for product availability.

Note2: Dropout voltage is defined for V_{OUT}≥2.5V device only.

**: Future product, contact factory.*

Linear Regulators

8V Input, Low Quiescent Current Linear Regulator

UM1550/UM1560

Key Features

- Input Voltage Range: 1.8V to 8V
- 250mA Guaranteed Output Current
- Low Dropout Voltage: 250mV (Typ) at 200mA
- Low Quiescent Current: 2.5µA @ $V_{IN}=8V$ (Typ)
- Low Noise: 115µV_{RMS} (10Hz to 100kHz)
- Available Fixed Output Voltage from 1.2V to 5.0V with 0.1V Step
- With Shutdown Control (UM1560)
- Output Current Limit

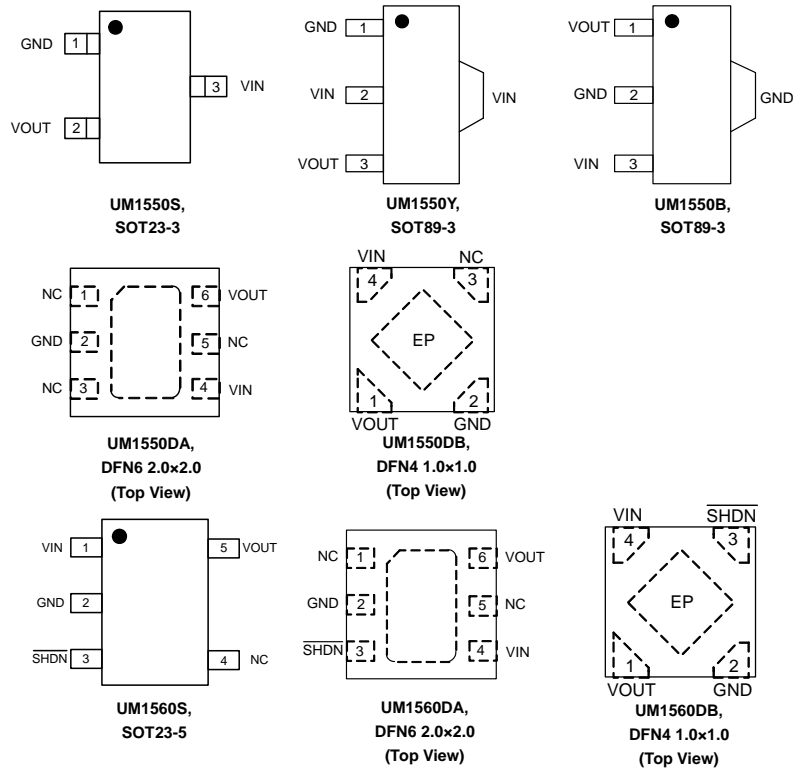
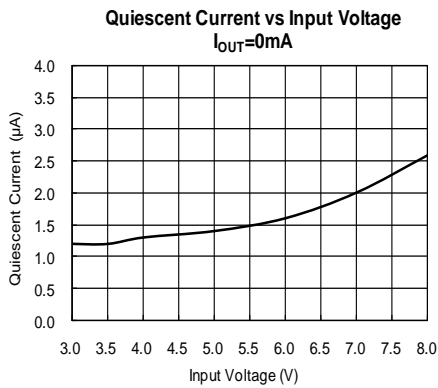

UM1550/UM1560 Pin Configurations

300mA, Micropower, Dual Channel VLDO Linear Regulator

UM4750S/UM4750DA/UM4750DC

Key Features

- Very Low Dropout: <200mV @ 100mA
- Operating Voltage Range: 2.5V to 5.5V
- Low Noise: 200µV_{RMS} (10Hz to 100kHz)
- Dual LDO Outputs (300mA/300mA)
- Output Current Limit
- Stable with 1µF Output Capacitor
- Thermal Overload Protection
- Low Profile SOT23-6, 6-Lead DFN2.0x2.0 and 8-Lead DFN3.0x3.0 Packages

The UM4750 series are dual channel very low dropout (VLDO) linear regulators with separated enable control. The range of output voltage is from 1.2V to 5.0V while operated from 2.5V to 5.5V input. Typical output noise is only 200µV_{RMS} and maximum dropout is just 200mV at the load current of 100mA.

Naming Rule

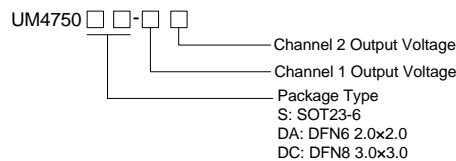

Available Voltage Version

Code	Voltage	Code	Voltage	Code	Voltage	Code	Voltage
A	5	F	4.2	L	3.3	R	1.8
B	4.8	G	4	M	3	S	1.5
C	4.7	H	3.8	N	2.8	T	1.3
D	4.5	J	3.6	P	2.7	U	1.2
E	4.3	K	3.5	Q	2.5		

Applications

- Bluetooth/802.11 Cards
- PDAs and Notebook Computers
- Portable Instruments and Battery-Powered Systems
- Cellular Phones

Benefits

- Low Profile Packages
- Separated Enable Control
- Available Multiple Output Voltage Combination

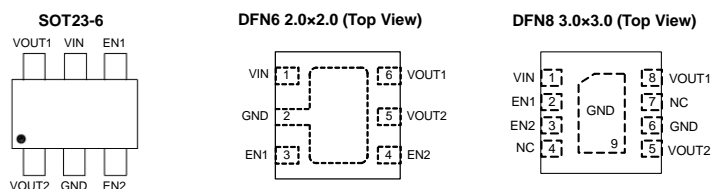

UM4750 Pin Configurations

Linear Regulators

18V, 30mA, Low Consumption Linear Regulator

UM1430/UM1440

Key Features

- Input Voltage Range: 3.6V to 18V
- Output Voltage: 2.0V to 6.0V with 100mV Interval
- 30mA Guaranteed Output Current
- Low Quiescent Current: 4.8µA (Typ) at 18V Input
- Low Dropout Voltage: 200mV (Typ) at 30mA
- With Enable Control (UM1440S/UM1440Y)

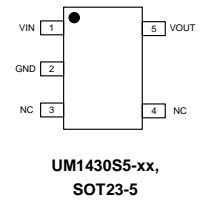
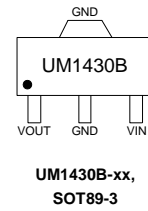
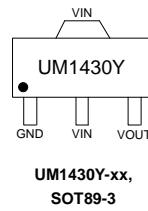
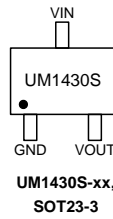
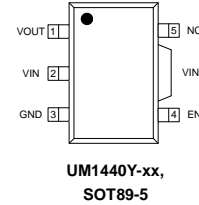
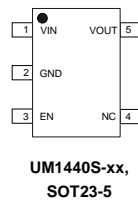
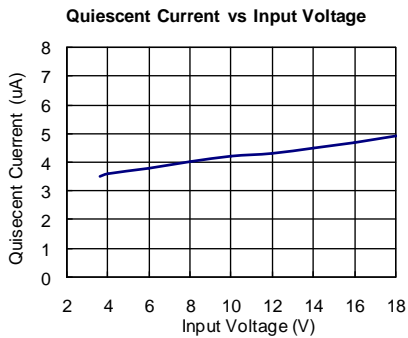

UM1430/UM1440 Pin Configurations

350mA, Micropower, Low Dropout Linear Regulator

UM1650/UM1750

Key Features

- Input Voltage Range: 2.5V to 6.0V
- 350mA Guaranteed Output Current
- Fixed Output Voltage of UM1650 and UM1750 from 1.0V to 4.0V with 0.1V Interval
- Adjustable Output Voltage of UM1750: 1.0V to 5.0V
- ±2% Voltage Accuracy at $V_{OUT} > 1.5V$
- ±30mV Voltage Accuracy at $V_{OUT} \leq 1.5V$
- Low Dropout Voltage: 150mV (Max) at 150mA
- PSRR=63dB @ f=100Hz
- Excellent Load Transient Response
- Low Quiescent Current: 90µA (Typ)

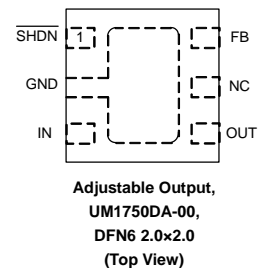
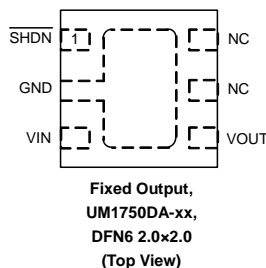
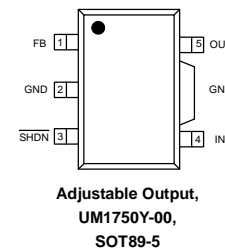
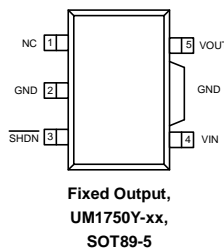
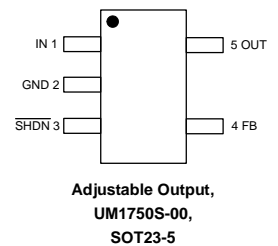
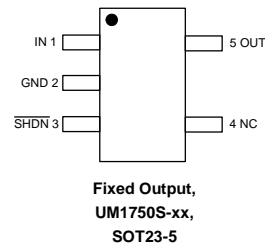
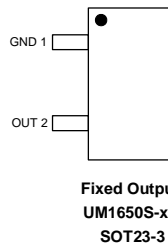

UM1650/UM1750 Pin Configurations

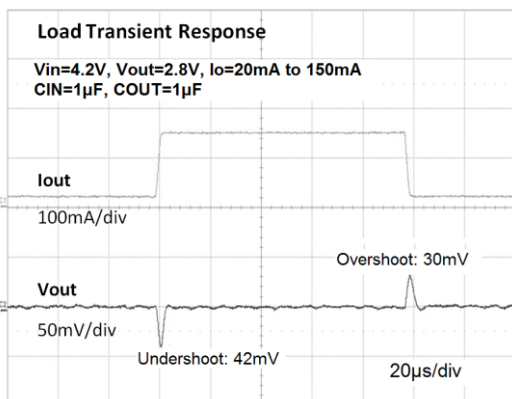

Linear Regulators

500mA, Micropower, Ultra Low Vdrop Linear Regulator

UM1770

Key Features

- Very Low Dropout: 320mV (Max) at 500mA
- Low Enable Threshold Voltage
- Maximum Input Voltage: 6.0V
- Fixed Output Voltage: 1.0V to 4.0V with 0.1V Interval
- Adjustable Output Voltage: 1.0V to 5.0V
- $\pm 2.0\%$ Voltage Accuracy at 500mA
- Under Voltage Lockout
- Output Current Limit
- Short-Circuit and Thermal Overload Protection

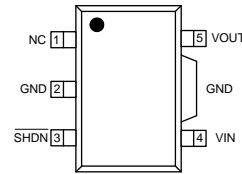
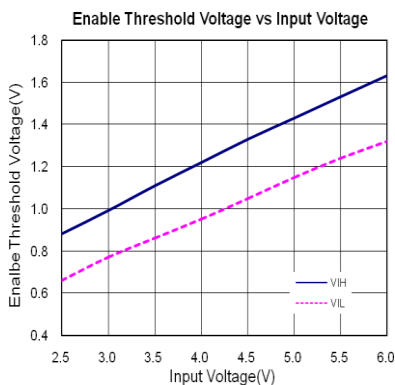

Fixed Output,
UM1770Y-xx,
SOT89-5

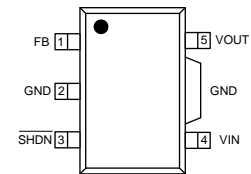

Adjustable Output,
UM1770Y-00,
SOT89-5

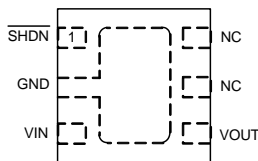

Fixed Output,
UM1770DA-xx,
DFN6 2.0x2.0
(Top View)

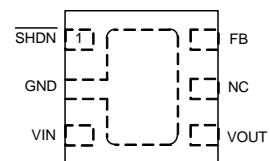

Adjustable Output,
UM1770DA-00,
DFN6 2.0x2.0
(Top View)

UM1770 Pin Configurations

Ultra Low Quiescent Current Linear Regulator

UM153xx/UM154xx

Key Features

- Ultra Low I_Q : 0.8 μ A @ $V_{IN}=3V$
- Operating Voltage Range: 2.2V to 5.5V
- Dropout Voltage:
100mV (Typ) @ $I_{LOAD}=50mA$, $V_{OUT}>3.0V$
- Output Voltage: 1.3V to 5.0V
- 100mA Guaranteed Output Current @ $V_{IN}\geq 3V$
- 200mA Guaranteed Output Current @ $V_{IN}\geq 3.5V$
- Fast Transient Response
- With Enable Control (UM154xx)

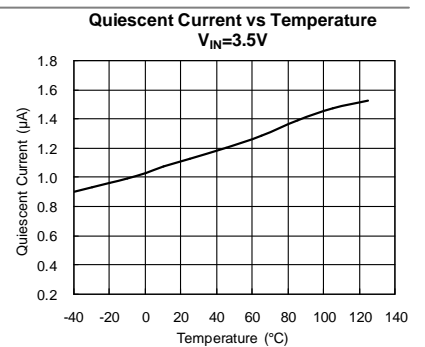
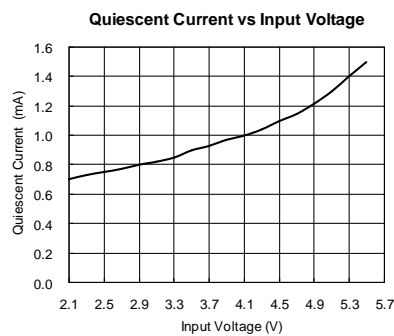

Applications

- Battery-Powered Systems
- Reference Voltage Sources
- Cameras, Video Cameras
- Portable AV Systems
- Portable Games
- Cellular Phones

Benefits

- Very Low Operating Voltage: 2.2V
- Ultra Low I_Q Over All Operating Voltage Range: <3 μ A

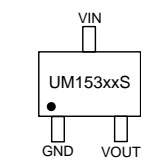

UM153xxS, SOT23-3

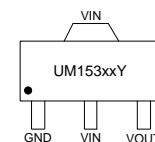

UM153xxY, SOT89-3

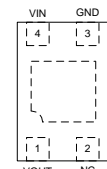

UM153xxDA, DFN4 1.8x1.2
(Top View)

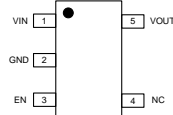

UM154xxS, SOT23-5

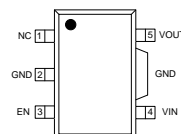

UM154xxY, SOT89-5

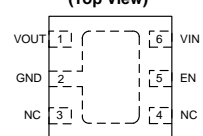

UM154xxDA, DFN6 2.0x2.0
(Top View)

UM153xx/UM154xx Pin Configurations

Product Selection Guide

Switching Regulators

DC/DC Buck Converters

Part Number	Description	V _{IN} (V)	V _{OUT} (V)	I _{OUT} (mA) (Max)	Frequency (MHz) (Typ)	Peak Efficiency	Package
Sync Low Voltage Buck Converters (V_{IN}≤6V)							
UM3500	Current Mode PWM Buck	2.5~5.5	0.6~V _{IN}	600	1.5	96%	SOT23-5
UM3501	Current Mode PWM Buck with Light Load Mode	2.5~5.5	0.6~V _{IN}	600	1.2	90%	SOT23-5 DFN6 2.0×2.0
UM3502QA	Current Mode PWM Buck with Integrated Inductor	2.5~5.5	0.6~5.0	600	1.2	90%	QFN24 4.0×4.0
UM3510	Current Mode PWM Buck with Light Load Mode and Mode Selection	2.5~6.0	0.6~V _{IN}	1000	2.25	95%	SOT23-6 DFN6 2.0×2.0
High Input Voltage High Output Current Buck Converters (V_{IN}≥6V, I_{OUT}≥2A)							
*UM5482S8	Current Mode PWM Buck	4.75~18.0	1.8~5.0	2000	0.34	90	SOP8

DC/DC Boost Converters

Part Number	Description	V _{IN} (V)	V _{OUT} (V)	I _{LIMIT} (mA) (Max)	Frequency (MHz) (Typ)	Peak Efficiency	Package
*UM3429	Voltage Mode PWM Boost with Light Load Mode	0.9~4.4	2.5~5	600	0.6	92%	SOT23-6 DFN8 2.0×2.0
UM1660	Constant Voltage PFM Boost Converter	2.0~6.0	2.0~28	450	1 (Max)	88%	SOT23-5 DFN6 2.0×2.0
UM1665	Constant Voltage PFM Boost Converter	2.0~6.0	2.0~28	500	1 (Max)	88%	SOT23-5 DFN6 3.0×3.0

LED Backlight Boost Drivers

Part Number	Description	V _{IN} (V)	V _{OUT} (V) (Max)	I _{LIMIT} (mA) (Max)	Frequency (MHz) (Max)	Peak Efficiency	Package
UM1661	Constant Current PFM Boost Converter with Over Voltage Protection	2.0~6.0	24	1600	2	88%	SOT23-6
*UM1663	Constant Current PWM Boost Converter	2.7~5.5	40	1200	1	90%	SOT23-6 DFN8 2.0×2.0

LED Lighting Buck Drivers

Part Number	Description	V _{IN} (V)	V _{SENSE} (mV) (Typ)	I _{LIMIT} (mA) (Min)	Frequency (MHz) (Max)	Peak Efficiency	Package
UM1350	30V Input 350mA Step-Down Current Mode LED Driver	7~30	100	370	1	>90%	SOT23-5
UM1351	35V Input 700mA Step-Down Current Mode LED Driver	6~35	100	1000	1	>90%	SOT23-5 SOT89-5
UM1360	40V, 1A Step-Down Current Mode LED Driver, with Frequency Jitter	6~40	100	1200	1	>90%	SOT89-5
UM1361S	40V Input 1A Step-Down Current Mode LED Driver	6~40	100	1500	1	>90%	SOT23-5

*: Future product, contact factory.

Switching Regulators

1A, 2.25MHz, Synchronous Step-Down DC-DC Converter

UM3510S/UM3510DA

Key Features

- High Efficiency: Up to 95%
- 2.5V to 6.0V Input Voltage Range
- 1000mA Output Current
- 2.25MHz Constant Switching Frequency
- Integrated Main Switch and Synchronous Rectifier. No External Schottky Diode Required.
- Low Quiescent Current: 56µA
- Thermal Fault Protection
- <1µA Shutdown Current
- Space Saving SOT23-6 and DFN6 2.0x2.0 Packages

Benefits

- Extremely Easy to Use
- Tiny Overall Solution Reduces System Cost
- Two Operating Modes are Optional at Light Load Condition

The UM3510 is a high efficiency pulse-width-modulation (PWM) synchronous step-down DC-DC converter with an input voltage range of 2.5V to 6.0V. It provides up to 1000mA output current from a single Li-ion cell. The UM3510 operates at 2.25MHz fixed switching frequency and enters Power Save Mode to maintain high efficiency at light load condition.

For low noise applications, the device can be forced into fixed frequency PWM mode by pulling the MODE pin high.

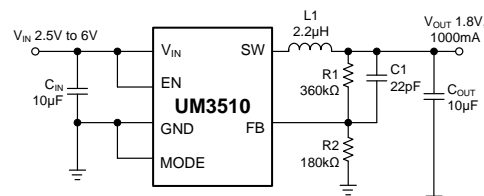

UM3510 Typical Application Circuit

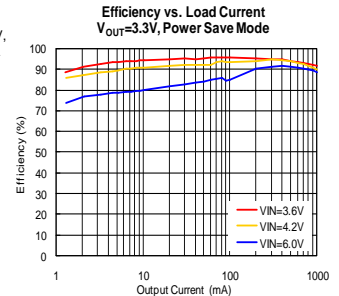

600mA, 1.2MHz, Synchronous Step-Down DC-DC Converter

UM3501/UM3501DA

Key Features

- High Efficiency: Up to 90%
- 2.5V to 5.5V Input Voltage Range
- 600mA Output Current
- 1.2MHz Constant Switching Frequency
- Integrated Main Switch and Synchronous Rectifier
- Pulse Skipping Mode Operation at Light Load Condition
- Low Quiescent Current: 50µA
- <1µA Shutdown Current
- Lead Free SOT23-5 (UM3501) and DFN6 2.0x2.0 (UM3501DA) Packages

Benefits

- Pulse Skipping Mode Improves Efficiency at Light Load Operation
- Synchronous Rectifier, No External Schottky Diode Required
- Ultra Low Shutdown Current

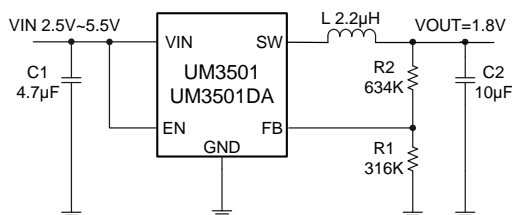

UM3501/UM3501DA Typical Application Circuit

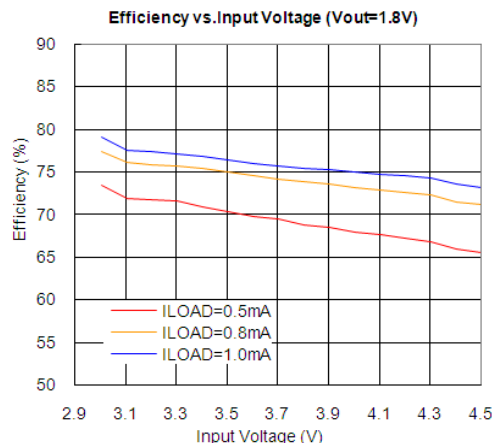
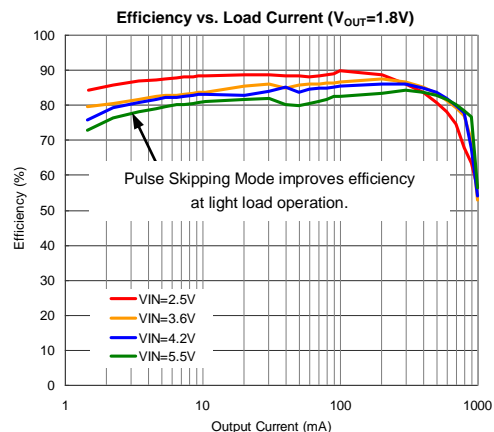

Switching Regulators

Low-Profile, 600mA, Synchronous Step-Down Converter with Integrated Inductor

UM3502QA

Key Features

- Ultra Small QFN24 4.0x4.0x1.05 Package
- Integrated Inductor
- No Schottky Diode Required
- High Efficiency: Up to 90%
- 600mA Output Current
- 0.6V Minimum Output Voltage
- 2.5V to 5.5V Input Voltage Range
- <math><1\mu\text{A}</math> Shutdown Current
- Pulse Skipping Mode Operation
- Thermal Fault Protection

Benefits

- Embedded Inductor
- Small PCB Area Needed
- Extremely Easy to Use
- Tiny Overall Solution Reduces System Cost
- Low Ripple and Noise

The UM3502QA is a high-efficiency, step-down DC-DC converter with a constant PWM frequency, current mode architecture. It is capable of delivering 600mA output current over a wide input voltage range from 2.5V to 5.5V. The UM3502QA automatically turns off the synchronous rectifier while the inductor current is low, and enters pulse skipping mode at light load condition. This can increase efficiency. It is an ideal choice to be used to replace less efficient LDO to achieve improved efficiency in space restricted applications. The UM3502QA enters shutdown mode and consumes less than $1\mu\text{A}$ when EN pin is pulled low.

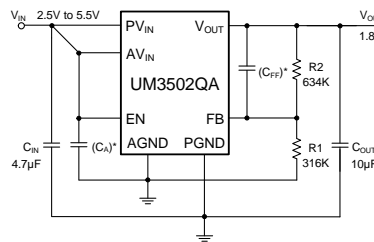

* C_A and C_{FF} are optional.

UM3502QA Typical Application Circuit

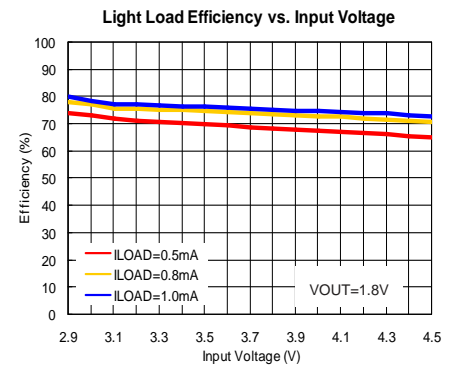

28V Low Power DC/DC Boost Converter

UM1660S/UM1660DA

Key Features

- 2.0V to 6.0V Input Voltage Range
- Adjustable Output Voltage up to 28V
- 400mA Internal Switch Current
- Up to 1MHz Switching Frequency
- 36µA Typical No Load Quiescent Current
- 1µA Maximum Shutdown Current
- Internal Soft-Start
- Tiny SOT23-5 and DFN6 2.0x2.0 Packages

Applications

- LCD Bias Supply
- White LED Supply for LCD Backlights
- Digital Still Cameras
- PDAs, Organizers and Handheld PCs
- Cellular Phones
- Standard 3.3V/5V to 12V Conversion

The UM1660 is a PFM controlled step-up DC-DC converter with a switching frequency up to 1MHz. The device is ideal to generate output voltage for small to medium LCD bias supplies and white LED backlight supplies from a single cell Li-ion battery. The part can also be used to generate standard 3.3V/5V to 12V power conversions.

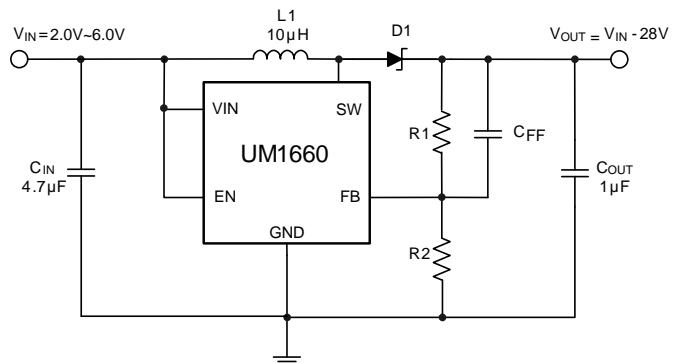

UM1660 Typical Application Circuit

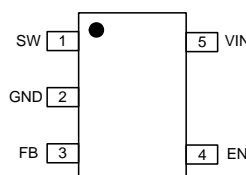

UM1660S

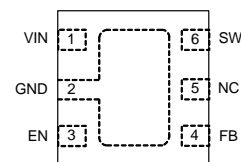

UM1660DA (Top View)

Switching Regulators

30V, 350mA LED Lighting Driver

UM1350

Key Features

- Internal 30V NDMOS Switch
- 350mA Output Current
- Wide Input Voltage Range: 6V to 30V
- $\pm 5\%$ LED Current Accuracy
- High Efficiency (up to 95%)
- Analog or PWM Dimming Control
- 40V Transient Capability
- Inherent Open-Circuit LED Protection
- Output Shutdown Control
- Up to 1MHz Switching Frequency
- Pb-Free SOT23-5 Package

Applications

- MR16 and General Lighting
- Automotive Lighting
- Low Voltage Industrial Lighting
- Illuminated Signs

Benefits

- DC Voltage or PWM Dimming
- High Efficiency (up to 95%)
- Inherent Open-Circuit LED Protection

The UM1350 is capable of driving single or multiple series connected LEDs efficiently from a voltage source higher than the LED voltage. This step-down converter provides an externally adjustable output current of up to 350mA from an input supply between 6V and 30V. It can even reach 8 watts of output power, depending on supply voltage and external components. The UM1350 is available in a low profile SOT23-5 package.

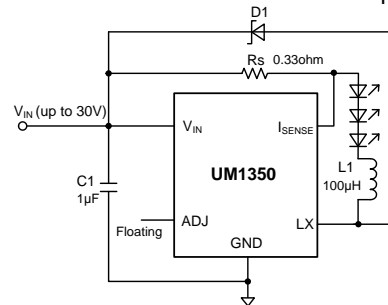

Typical Application Circuit

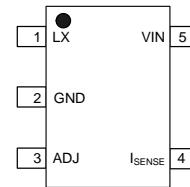

SOT23-5
UM1350 Pin Configuration

40V, 1A LED Lighting Driver

UM1360Y

Key Features

- Integrated 40V 0.4 Ω NDMOS
- 1A Output Current
- Wide Input Voltage Range: 6V to 40V
- $\pm 5\%$ LED Current Accuracy
- Up to 95% Efficiency
- Adjustable Constant LED Current
- Analog or PWM Dimming Control
- Improved EMI through Frequency Jitter
- Over Temperature and Open-Circuit LED Protection
- Up to 1MHz Switching Frequency
- Pb-Free SOT89-5 Packages

Applications

- Low Voltage Industrial Lighting
- Illuminated Signs
- DC/DC or AC/DC LED Driver Application
- General Purpose, Constant Current Source

Benefits

- DC Voltage or PWM Dimming
- Inherent Open-Circuit LED Protection

The UM1360 is a PWM step-down converter with internal power switch, designed for driving single or multiple series connected LEDs efficiently from a voltage source higher than the LED voltage. The device operates from an input supply between 6V and 40V and employs hysteretic control with a high side current sense resistor to set the constant output current up to 1A.

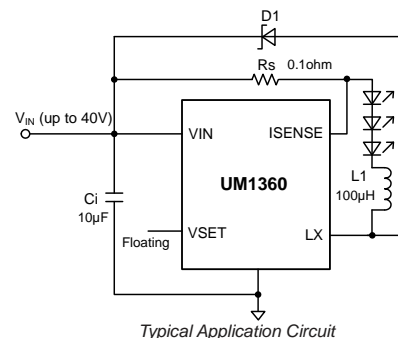

Typical Application Circuit

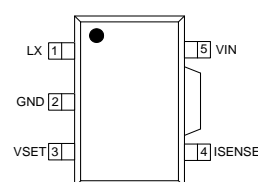

UM1360Y
SOT89-5
UM1360 Pin Configurations

Product Selection Guide

Power Management

µP Supervisory

Part Number	Description	Reset Threshold (V)	Timeout Period (Min) (ms)	Watchdog Feature	Watchdog Timeout	I _{CC} (µA)	Output Type	Operating Temp (°C)	Package
UM803xx	Power On Reset	**	140	No	NA	2	Open-Drain, Active Low	-40~85	SOT23-3 SOT323
UM809xx	Power On Reset	***	140	No	NA	3	Push-Pull, Active Low	-40~85	SOT23-3 SOT323
UM810xx	Power On Reset	***	140	No	NA	3	Push-Pull, Active High	-40~85	SOT23-3 SOT323
UM805xE	Power On Reset with General Manual Reset	**	140	No	NA	2	Open-Drain, Active Low	-40~85	SOT143
UM811xE	Power On Reset with General Manual Reset	**	140	No	NA	2	Push-Pull, Active Low	-40~85	SOT143
UM812xE	Power On Reset with General Manual Reset	**	140	No	NA	2	Push-Pull, Active High	-40~85	SOT143
UM807xxE	Power On Reset with 1.68s/6.72s/10.08s Manual Reset Pulse Width	**	140	No	NA	2	Open-Drain, Active Low	-40~85	SOT143
UM821xxE	Power On Reset with 1.68s/6.72s/10.08s Manual Reset Pulse Width	**	140	No	NA	2	Push-Pull, Active Low	-40~85	SOT143
UM822xxE	Power On Reset with 1.68s/6.72s/10.08s Manual Reset Pulse Width	**	140	No	NA	2	Push-Pull, Active High	-40~85	SOT143
UM813xS	Power On Reset with Manual Reset and Watchdog	**	140	Yes	1.6s	80	Push-Pull, Active High	-40~85	SOP8
UM706xS	Power On Reset with Manual Reset and Watchdog	**	140	Yes	1.6s	80	Push-Pull, Active Low	-40~85	SOP8
UM708xS	Power On Reset with Manual Reset	**	140	No	NA	80	Active Low & High	-40~85	SOP8

** : Available reset threshold voltage: 4.63V, 4.38V, 4.00V, 3.08V, 2.93V, 2.63V, 2.32V

*** : Available from 2.0V to 5.0V with 0.1V interval

Power Switches

Part Number	Description	V _{IN} (V)	I _{LIMIT} (A) (Min)	I _{LOAD} (A) (Max)	Flag Delay Time (ms) (Typ)	R _{DS(ON)} (mΩ)	Package
UM9711S	High-Side Over Current Protection Power Switch with Flag	2.5~5.5	1.6	1.5	12	90	SOT23-5
*UM9711S8	High-Side Over Current Protection Power Switch with Flag	2.5~5.5	1.6	1.5	12	90	SOP8
*UM9711AS8	High-Side Over Current Protection Power Switch without Flag	2.5~5.5	1.6	1.5	12	90	SOP8
*UM9811S8	High-Side Over Voltage Protection Power Switch with Flag	2.5~5.5	1.6	1.5	12	90	SOP8
UM3865P	Load Switch with Level Shifter	1.8~8.0		1	NA	300	SOT363
*UM2291	80mΩ, 1.2A Load Switch	1.5~5.5	1.5	1.2	NA	80	SOT363 DFN6 2.0x2.0

Small Signal MOSFET

Part Number	Description	BV _{DSS} (V)	V _{GS(TH)} (V)	Continuous Drain Current Rating (A)	R _{DS(ON)} (mΩ) V _{GS=-4.5V}	Package
UM2301S	20V Pch	-20	-0.6	-1.5	200	SOT23-3
UM2301P	20V Pch	-20	-0.6	-1.1	200	SOT323
UM2302S	20V Nch	20	0.6	2	90	SOT23-3
UM2302P	20V Nch	20	0.6	1.6	90	SOT323
UM2362	60V Nch	60	1	0.115	1700	SOT23-3 SOT323
UM8516	20V Pch with Internal G-S Protection	-20	-0.6	-4(Max)	52	SOT23-6

*: Future product, contact factory.

Power Management

Supervisory Circuit with Watchdog and Manual Reset

UM706xS

Key Features

- Manual Reset: Active-Low Reset Output
- Supply Current: 80µA (Typ)
- Minimum 140ms Reset Pulse Width
- 1.25V Voltage Monitor for Power-Fail or Low-Battery Warning
- Independent Watchdog Timer-1.6s Timeout

Applications

- CPU and Logic Circuit Reset
- Power Fail Detectors
- Computers
- Embedded Systems
- Battery-Powered Equipments
- Intelligent Instruments

Benefits

- Integrated Manual Reset and Watchdog

The UM706 provides four functions:

- A reset output during power-up, power-down and brownout conditions. The reset output is driven active within 10µs of power supply falling through the reset voltage threshold. Reset is keeping active for a minimum of 140ms after system power supply has risen above the reset threshold. Reset threshold suitable for operation with variety of supply voltage are available.
- An independent watchdog output that goes low if the watchdog input has not been toggled within 1.6 seconds.
- A 1.25V threshold detector for power-fail warning, low-battery detection, or for monitoring a power supply other than +5V.
- An active-low manual-reset input.

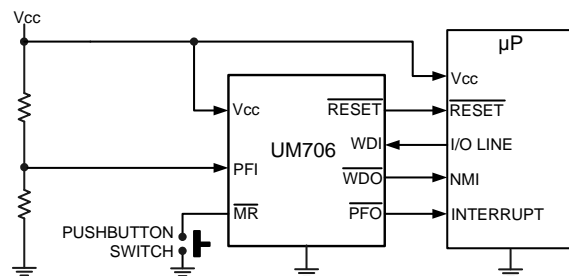

UM706xS Typical Application Circuit

Low Supply Current Supervisory Circuit

UM809xx/UM810xx

Key Features

- Wide Operation Voltage Range of 1V to 10V
- Typical Quiescent Current of 3µA
- Minimum 140ms Reset Pulse Width
- No External Components Required
- Available Reset Threshold from 2.0V to 5.0V, Step=100mV
- Correct Logic Output Guaranteed to $V_{CC}=1.0V$
- Push-Pull Low Active Reset Output (UM809)
- Push-Pull High Active Reset Output (UM810)
- 3-Pin Small SOT323 and SOT23 Packages

Applications

- CPU and Logic Circuit Reset
- Power Fail Detectors
- Computers
- Embedded Systems
- Battery-Powered Equipments
- Intelligent Instruments

Benefits

- No External Components Required, Saving PCB Space
- Wide Operation Voltage Range of 1V to 10V
- Ultra Low Quiescent Current: 3µA (Typ)

The UM809/810 series are ultra low current, cost effective system supervisory circuits designed to monitor the power supplies in digital systems. The reset output is driven active within 10µs of power supply falling through the reset voltage threshold. Reset is keeping active for a minimum of 140ms after system power supply has risen above the reset threshold. Reset threshold suitable for operation with variety of supply voltage are available.

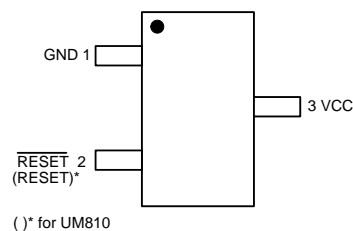

UM809xx/UM810xx Pin Configurations (SOT23-3, SOT323)

Power Management

4-Pin μP Voltage Monitor with Manual Reset Input UM805/UM811/UM812

Key Features

- No External Components
- V_{CC} Transient Immunity
- Correct Logic Output Guaranteed to $V_{CC}=1.0\text{V}$
- Precision V_{CC} Monitoring of 3.0V, 3.3V and 5.0V Supplies
- 2 μA Supply Current
- 140ms Minimum Power-On Reset Pulse Width
- Available in 3 Output Configurations:
Open-Drain Active-Low $\overline{\text{RESET}}$ Output (UM805)
Push-Pull Active-Low $\overline{\text{RESET}}$ Output (UM811)
Push-Pull Active-High RESET Output (UM812)
- 4-Pin SOT143 Package
- Wide Operation Temperature: -40°C to $+85^{\circ}\text{C}$

Applications

- Computers
- Controllers
- Portable/Battery-Powered Equipments
- Intelligent Instruments
- Critical μP and μC Power Monitoring

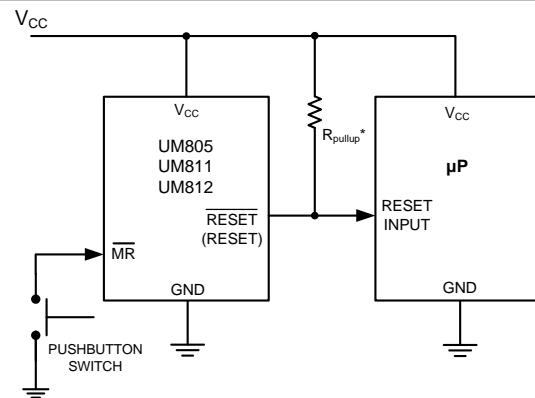

*UM805 ONLY
() are for UM812

Typical Application Circuit

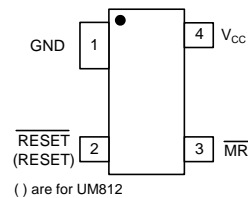

UM805/UM811/UM812 Pin Configurations

μP Reset Circuit with Long Manual Reset Setup Period UM807/UM821/UM822

Key Features

- No External Components
- V_{CC} Transient Immunity
- Correct Logic Output Guaranteed to $V_{CC}=1.0\text{V}$
- Precision V_{CC} Monitoring of 3.0V, 3.3V and 5.0V Supplies
- 2 μA Supply Current
- 140ms Minimum Power-On Reset Pulse Width
- Available in 3 Manual Reset Setup Periods (t_{MR}):
A, 10.08s; B, 6.72s; C, 1.68s
- Available in 3 Output Configurations:
Open-Drain Active-Low $\overline{\text{RESET}}$ Output (UM807)
Push-Pull Active-Low $\overline{\text{RESET}}$ Output (UM821)
Push-Pull Active-High RESET Output (UM822)
- 4-Pin SOT143 Package
- Wide Operation Temperature: -40°C to $+85^{\circ}\text{C}$

Applications

- Set-Top Boxes
- Consumer Electronics
- DVD Players
- Cable/DSL Modems
- Industrial Equipments
- Automotive Systems
- Medical Devices

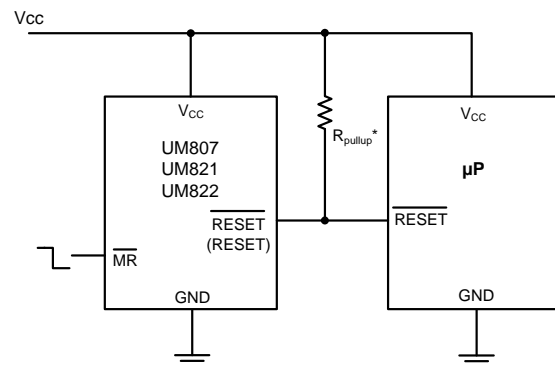

*UM807 ONLY
() are for UM822

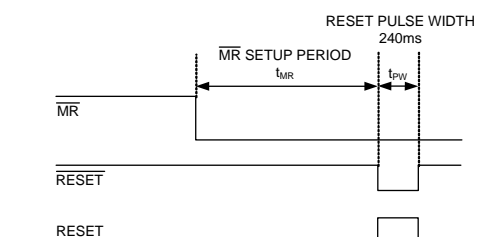

Typical Application Circuit and Manual Reset Setup Period

Product Selection Guide

Analog and Data Switches

Low Ron Analog Switches (Ron<1Ω)

Part Number	V _{CC} (V)	Features	R _{ON} (Ω) (Typ)	Bandwidth (MHz)	Off Isolation @ 100kHz (dB)	Cross-Talk @ 100kHz (dB)	Package
UM4157	1.65–4.3	Single SPDT	0.8	70	-75	-75	SOT363
UM2268	1.8–4.4	Dual SPDT	0.4	80	-78	-93	QFN10 1.8x1.4 QFN10 2.1x1.6
UM4684	1.8–5.5	Dual SPDT	0.5	20	-69	-69	CSP10 2.0x1.5 MSOP10
UM5223	1.65–4.5	Dual SPDT	0.5	75	-78	-92	QFN10 1.8x1.4
UM3699A	1.65–5.5	Dual DPDT	0.6	20	-62	-62	QFN16 3.0x3.0

High Bandwidth Data Switches (BW>200MHz)

Part Number	V _{CC} (V)	Features	R _{ON} (Ω) (Max)	Bandwidth (MHz)	Off Isolation (dB)**	Cross-Talk (dB)**	Package
UM3156	1.65–5.5	Single SPDT, Low I _{CCT}	10	230	-60	-54	SOT363
UM3157	1.65–5.5	Single SPDT, Low I _{CCT}	10	250	-57	-54	SOT363
UM3257	1.65–5.5	Dual SPDT, Low I _{CCT}	10	250	-55	-54	DFN12 3.0x1.6
UM3258	1.65–5.5	Dual SPDT, Low I _{CCT}	10	300	-55	-54	DFN12 3.0x1.0
UM4717	1.8–5.5	Dual SPDT	6	300	-55	-80	CSP10 1.9x1.4 QFN10 1.8x1.4
UM4258Q	1.8–5.5	Dual SPDT	4.5	300	-55	-80	QFN10 1.8x1.4
UM3670	1.8–5.5	Dual DPDT	10	300	-55	-60	QFN16 3.0x3.0 QFN16 2.6x1.8
UM7222	2.7–5.5	Dual SPDT	9	550	-25dB @ 250MHz	-48dB @ 250MHz	QFN10 1.8x1.4 QFN10 2.1x1.6 MSOP10
*UM7227	2.7–5.5	Dual SPDT	9	720	-25dB @ 250MHz	-48dB @ 250MHz	QFN10 1.8x1.4
UM9636	2.7–12	Dual SPDT	110	720	-58	-67	QFN10 1.8x1.4
*UM1153	2.7–5.0	Single DPDT, Negative Signal Capability	4.6 (Audio) 5.5 (USB)	900 (USB)	-81dB @ 100kHz	-93dB @ 100kHz	QFN10 1.8x1.4

Video Switch

Part Number	V _{CC} (V)	Features	R _{ON} (Ω) (Max)	Bandwidth (MHz)	Off Isolation (dB)**	Cross-Talk (dB)**	Package
UM330	1.8–5.5	Quad SPDT	10	500	-50	-60	TSSOP16

*: Future product, contact factory.

** : Typically, the spec value is measured at f=10MHz, otherwise see the measurement condition in the table.

Analog and Data Switches

High Speed USB2.0 (480Mbps) DPDT Switch

UM7222/UM7222A/UM7222MA

Key Features

- OVT on D+ and D- up to 5.5V
- Power Off Protection:
When $V_{CC}=0V$, D+ and D- Can Tolerate up to 5.5V
- Low Crosstalk: -50dB (250MHz)
- Low Current Consumption: $1\mu A$
- Channel On-Capacitance: 6.5pF (Typ)
- V_{CC} Operating Range: +2.7V to +5.5V
- 550MHz Bandwidth (or Data Frequency)
- ESD Rating: $\pm 4kV$ I/O to GND

Applications

- Differential Signal Data Routing
- USB2.0 Signal Routing
- Cell Phones, PDAs, Digital Cameras and Notebooks
- LCD Monitors, TV and Set-Top Boxes

Benefits

- OVT on D+ and D-
- Power Off Protection

The UM7222/UM7222A/UM7222MA is a dual port high-speed, low-power data switch optimized for USB 2.0 signal switching. The UM7222/UM7222A/UM7222MA switch is configured in double-pole/double-throw DPDT. It handles bidirectional signal flow, achieving a 550 MHz -3dB bandwidth, and a port to port crosstalk and isolation at -50dB at 250MHz.

The UM7222/UM7222A/UM7222MA operates from a single +2.7V to +5.5V supply, with current consumption less than $1\mu A$.

The UM7222/UM7222A/UM7222MA features wide bandwidth and low bit-to-bit skew allow it to pass high-speed differential signal with good signal integrity, offers little or no attenuation of the high-speed signals at the outputs. Its high channel-to-channel crosstalk rejection results in minimal noise interface. Its bandwidth is wide enough to pass high-speed USB 2.0 differential signals (480Mbps). The control logic threshold is guaranteed to be compatible with 1.8V logic.

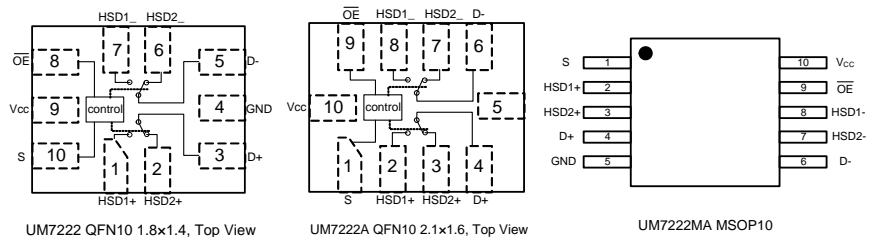

UM7222/UM7222A/UM7222MA Pin Configurations

High Voltage, High Bandwidth DPDT Data Switch

UM9636

Key Features

- Ron is Typically 83Ω at $V_{CC}=12V$
- Channel On-Capacitance: 6.5pF (Typ)
- Typically 720MHz -3dB Bandwidth
- Low Crosstalk: Typically -67dB (10MHz)
- Low Off-Isolation: Typically -58dB (10MHz)
- Low Voltage, 1.65V CMOS/TTL Compatible
- Low Current Consumption: $1\mu A$
- V_{CC} Operating Range: +2.7V to +12V
- Lead (Pb)-Free QFN10 1.8x1.4 Package

Applications

- High-End Data Acquisition
- Medical Instruments
- Precision Instruments
- High Speed Communications Applications
- Automated Test Equipments
- Sample and Hold Applications

Benefits

- Low Voltage, 1.65V CMOS/TTL Compatible

The UM9636 is a high-speed, low-power dual single-pole/double-throw (SPDT) analog switch that operates from a single +2.7V to +12V supply. The UM9636 features 720MHz -3dB bandwidth, -67dB crosstalk and -58dB off-isolation at 10MHz frequency. Wide bandwidth and low on resistant allow it to pass high-speed differential signal with good signal integrity. The switch is bidirectional and offers little or no attenuation of the high-speed signals at the outputs. Its high channel-to-channel crosstalk rejection results in minimal noise interference. Key applications for the UM9636 are logic level translation, pulse generator, and high speed or low noise signal switching in precision instrumentations and portable device designs.

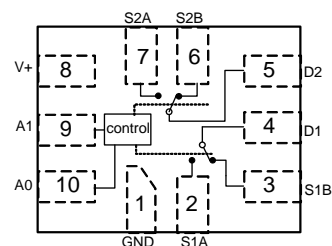

UM9636 QFN10 1.8x1.4, Top View
UM9636 Pin Configuration

Product Selection Guide

Interface and System Interconnect

RS485 Interface

Part Number	Description	Data Rate (Mbps) (Min)	Fail Safe	Transceivers on Bus	ESD (kV)		Package
					Contact	Air	
UM3085E	5V Supply, 1TX/1RX RS485 Interface	0.5	Yes	256	±8	±15	SOP8 DIP8
UM3088E	5V Supply, 1TX/1RX RS485 Interface	2.5	Yes	256	±8	±15	SOP8 DIP8
UM3483E	3.3V to 5.0V Supply, 1TX/1RX RS485 Interface	0.5	Yes	256	±8	±15	SOP8 DIP8
UM3486E	3.3V to 5.0V Supply, 1TX/1RX RS485 Interface	2.5	Yes	256	±8	±15	SOP8 DIP8
UM3352E	5V Supply, 1TX/1RX RS485 Interface	0.5	Yes	256	±8	±15	SOP8 DIP8
*UM3087E	5V Supply, 1TX/1RX RS485 Interface Auto Polarity Reversal	0.5	Yes	256	±8	±15	SOP8 DIP8
*UM3487E	3.3V to 5.0V Supply, 1TX/1RX RS485 Interface Auto Polarity Reversal	0.5	Yes	256	±8	±15	SOP8 DIP8

RS422 Interface

Part Number	Description	Data Rate (Mbps) (Min)	Fail Safe	Transceivers on Bus	ESD (kV)		Package
					Contact	Air	
UM491E	5V Supply, 1TX/1RX RS422 Interface	2.5	Yes	256	±8	±15	SOP14 DIP14
UM3491E	3.3V to 5.0V Supply, 1TX/1RX RS422 Interface	10	Yes	256	±8	±15	SOP14 DIP14
*UM488E	5V Supply, 1TX/1RX RS422 Interface	2.5	Yes	256	±8	±15	SOP8 DIP8
*UM3488E	3.3V to 5.0V Supply, 1TX/1RX RS422 Interface	10	Yes	256	±8	±15	SOP8 DIP8

RS232 Interface

Part Number	Description	Data Rate (kbps)	Operating Temperature (°C)	Fail Safe	ESD (kV)		Package
					Contact	Air	
UM202EEExE	Single 5V Powered 2TX/2RX	120	-40~+85	Yes	±8	±15	SOP16 DIP16 TSSOP16
UM232ECxExE	Single 5V Powered 2TX/2RX	120	0~+70	Yes	±8	±15	SOP16 DIP16 TSSOP16
UM232EEExE	Single 5V Powered 2TX/2RX	120	-40~+85	Yes	±8	±15	SOP16 DIP16 TSSOP16
UM3232EEExE	3V~5.5V Powered 2TX/2RX	250	-40~+85	Yes	±8	±15	TSSOP16 SOP16 SSOP16 DIP16
UM3222EEUE	3V~5.5V Powered 2TX/2RX with Enable and Shutdown Control	250	-40~+85	Yes	±8	±15	TSSOP20
UM3221EEExE	3V~5.5V Powered 1TX/1RX with Enable and Shutdown Control	250	-40~+85	Yes	±8	±15	TSSOP16 SSOP16
UM3243EEExx	3V~5.5V Powered 3TX/5RX	250	-40~+85	Yes	±8	±15	TSSOP28 SSOP28 SOP28 QFN32 5.0x5.0

*: Future product, contact factory.

Product Selection Guide

Interface and System Interconnect

Level Shifters

Part Number	Description	V _{CCA} (V)	V _{CCB} (V)	Max Data Rate (Mbps) V _{CCA} =3.3V	ESD (kV) (B Port)	Package
UM3301	1-Bit Auto Direction Detect, CMOS Output	1.2~3.6	1.65~5.5	100	±15	SOT563 DFN6 1.45x1.0
UM3302H	2-Bit Auto Direction Detect, CMOS Output	1.2~3.6	1.65~5.5	100	±15	CSP8 1.9x0.9
UM3304	4-Bit Auto Direction Detect, CMOS Output	1.2~3.6	1.65~5.5	100	±4	CSP12 1.9x1.4 QFN14 3.5x3.5 QFN16 2.8x1.6
UM3308	8-Bit Auto Direction Detect, CMOS Output	1.2~3.6	1.65~5.5	100	±15	CSP20 2.7x2.4
UM3202	2-Bit Auto Direction Detect, for Push-Pull or Open-Drain Applications	1.65~3.6	2.3~5.5	24Mbps (Push-Pull) 2Mbps (Open-Drain)	±15	CSP8 1.9x0.9 DFN8 1.7x1.35 QFN10 1.8x1.4 VSSOP8
UM3204	4-Bit Auto Direction Detect, for Push-Pull or Open-Drain Applications	1.65~3.6	2.3~5.5	24Mbps (Push-Pull) 2Mbps (Open-Drain)	±5	CSP12 1.9x1.4 QFN14 3.5x3.5 TSSOP14
UM3212	2-Bit Auto Direction Detect, for Push-Pull or Open-Drain Applications	1.0~3.3	1.8~5.0	3.4Mbps (Max)	±4	MSOP8 DFN8 2.1x1.6
UM2002	2-Bit Auto Direction Detect, for Push-Pull or Open-Drain Applications	1.0~3.3	1.8~5.0	3.4Mbps (Max)	±4	TSSOP8 SOP8
UM2001P	1-Bit Auto Direction Detect, for Push-Pull or Open-Drain Applications	1.0~3.3	1.8~5.0	3.4Mbps (Max)	±4	SOT363

Interface and System Interconnect

±15kV ESD-Protected, Slew-Rate-Limited, High-Speed and Fail-Safe RS485 Transceiver UM3085E/UM3483E

Key Features

- ESD Protection for RS-485 I/O Pins
±15kV—Human Body Model
±15kV—IEC 61000-4-2, Air Discharge
- True Fail-Safe Protection
- Low Current Shutdown Mode
- -7V to +12V Common-Mode Input Voltage Range
- Allows up to 256 Transceivers on the Bus
- Current Limiting for Driver Overload Protection
- UM3085: +5.0V Powered
UM3483: +3.0V to +5.5V Powered

Applications

- RS-485 Transceivers
- Level Translators
- Transceivers for EMI-Sensitive Applications
- Industrial-Control Local Area Networks

The UM3085E, UM3483E are ±15kV electrostatic discharge (ESD)-protected, high-speed transceivers for RS-485 communication that contain one driver and one receiver. These devices feature fail-safe circuitry, which guarantees a logic-high receiver output when the receiver inputs are open, shorted or idle. This means that the receiver output will be logic high if all transmitters on a terminated bus are disabled (high impedance).

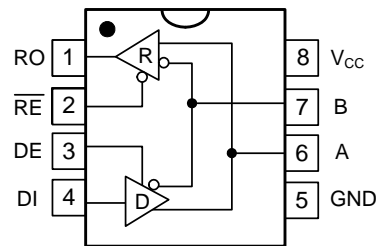

UM3085E/UM3483 Pin Configurations

Fail-Safe, Single Supply RS-232 Transceiver

UM3232E/UM3222E

Key Features

- Meets True EIA/TIA-232-F Standards from a +3.0V to +5.5V Power Supply
- Enhanced ESD Specifications:
±15kV Human Body Mode
±15kV IEC61000-4-2 Air Discharge
±8kV IEC61000-4-2 Contact Discharge
- 1µA Low Power Shutdown (UM3222E)
- 250 kbps Minimum Transmission Rate
- Guaranteed 30V/µs Max Slew Rate
- Compatible with 1.8V Logic @ V_{CC}=3.3V

Applications

- Notebooks and Palmtop Computers
- Battery-Powered Equipments
- Hand-Held Equipments
- POS Terminals

The UM3222E/UM3232E is dual driver, dual receiver RS-232 transceiver solutions intended for portable or hand-held applications. The UM3222E features a 1µA shutdown mode that reduces power consumption in battery-powered portable systems.

The UM3222E and UM3232E are pin, package, and functionally compatible with the industry standard products pin out, respectively.

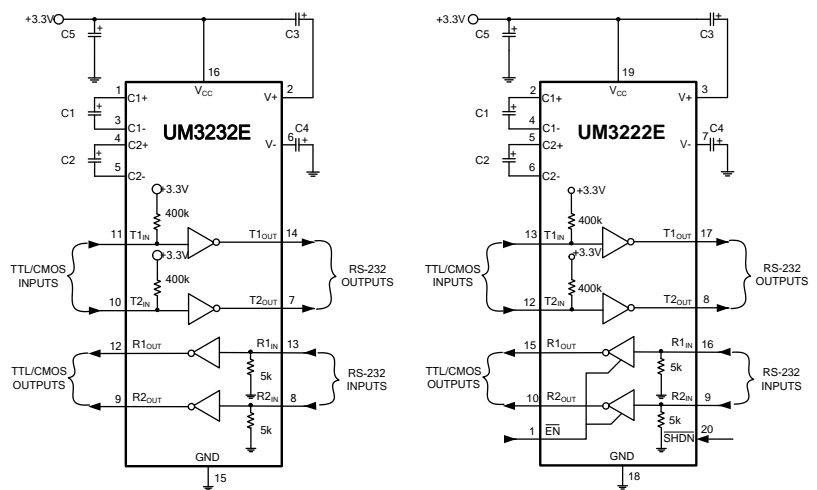

UM3232E/UM3222E Typical Operating Circuits

Interface and System Interconnect

+3V to +5.5V, 3-Driver/5-Receiver RS-232 Transceiver with Auto Shutdown

UM3243

Key Features

- Meets True EIA/TIA-232-F Standards from a +3.0V to +5.5V Power Supply
- Enhanced ESD Specifications:
±15kV Human Body Mode
±15kV IEC61000-4-2 Air Discharge
±8kV IEC61000-4-2 Contact Discharge
- 1µA Low Power Shutdown
- 250kbps Minimum Transmission Rate
- Guaranteed 30V/µs Max Slew Rate
- Latch-Up Performance Exceeds 200mA
- Hot Swap and Fail-Safe
- I/O Logic Compatible with 1.8V Logic @ $V_{CC}=3.3V$
- SOP28, SSOP28, TSSOP28 and QFN32 5.0x5.0 Packages

Applications

- Battery-Powered Systems
- PDAs
- Notebooks
- Laptops
- Palmtop PCs
- Hand-Held Equipments

The UM3243 is a 3-driver/5-receiver RS-232 transceiver with auto shutdown and low supply current. When the UM3243 does not sense a valid signal level on their receiver inputs, the on-board power supply and drivers shut down. The UM3243 requires only 4x0.1µF capacitors in 3.3V operation, and can operate from input voltages ranging from +3.0V to +5.5V. It is ideal for 3.3V-only systems, mixed 3.3V and 5.0V systems, or 5.0V-only systems that require true RS-232 performance.

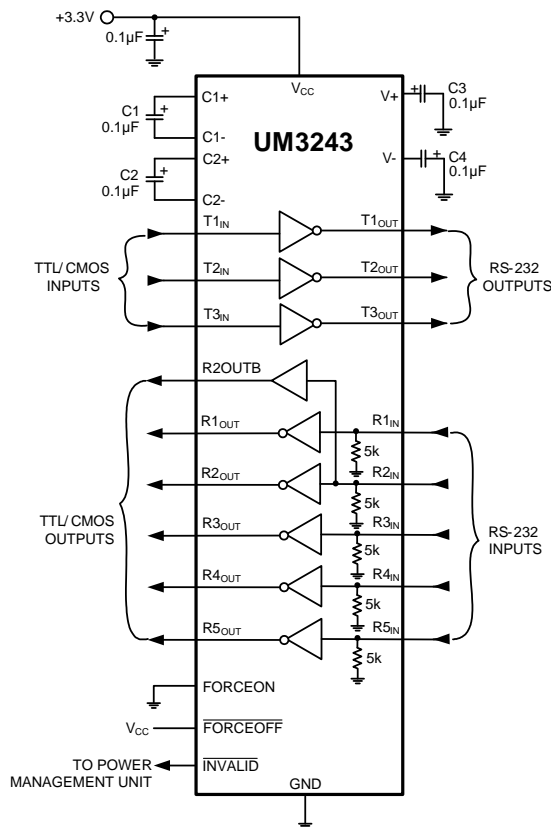

UM3243 Typical Operating Circuit

Interface and System Interconnect

2/4-Bit Bidirectional Voltage-Level Translator for Open-Drain and Push-Pull Applications

UM3202/UM3204

Key Features

- Max Data Rates: 24Mbps (Push-Pull), 2Mbps (Open-Drain)
- 2-Bit for UM3202
4-Bit for UM3204
- Bidirectional, No Direction Control Required
- 1.65V to 3.6V on A Port and 2.3V to 5.5V on B Port ($V_{CCA} \leq V_{CCB}$)
- $\pm 5kV$ ESD Protection on B Port
- No Power-Supply Sequencing Required
 V_{CCA} or V_{CCB} Can be Ramped First

Applications

- SPI, MICROWIRE and I²C Level Translation
- Low-Voltage ASIC Level Translation
- Portable POS Systems
- Portable Communication Devices
- Low-Cost Serial Interfaces
- Cell-Phones
- GPS
- Telecommunications Equipments

The UM3202/UM3204 is 2/4 channel ESD-protected level translator provide the level shifting necessary to allow data transfer in a multi-voltage system. Externally applied voltages, V_{CCB} and V_{CCA} , set the logic levels on either side of the device. A low-voltage logic signal present on the V_{CCA} side of the device appears as a high-voltage logic signal on the V_{CCB} side of the device, and vice-versa.

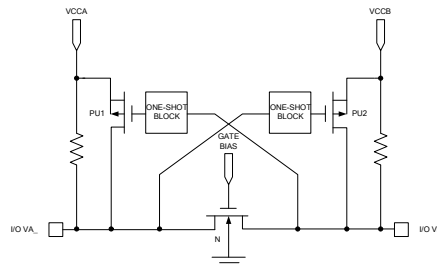

Block Diagram of UM3202/UM3204 I/O Cell

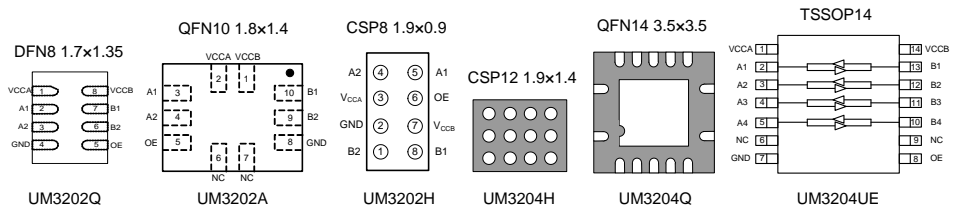

1/2/4/8-Bit Bidirectional Voltage-Level Translator with Auto Direction Sensing

UM3301/UM3302/UM3304/UM3308

Key Features

- Max Data Rates: 100Mbps
- 1-Bit for UM3301, 2-Bit for UM3302
4-Bit for UM3304, 8-Bit for UM3308
- Bidirectional, No Direction Control Required
- 1.2V to 3.6V on A Port and 1.65V to 5.5V on B Port ($V_{CCA} \leq V_{CCB}$)
- Enhanced ESD Protection on B Ports
- V_{CC} Isolation Feature: If Either V_{CC} Input is at GND, All Outputs are in the High-Impedance State
- OE Input Circuit Referenced to V_{CCA}
- Low Power Consumption

UM3301/UM3302/UM3304/UM3308 is level translator with auto direction sensing and enhanced ESD protection. This non-inverting translator uses two separate configurable power-supply rails. The A port is designed to track V_{CCA} . V_{CCA} accepts any supply voltage from 1.2V to 3.6V. The B port is designed to track V_{CCB} . V_{CCB} accepts any supply voltage from 1.65V to 5.5V.

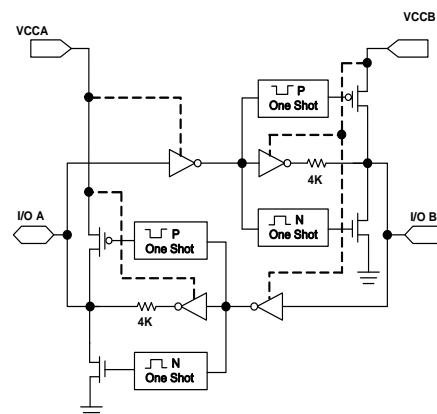

Block Diagram of UM3304 I/O Cell

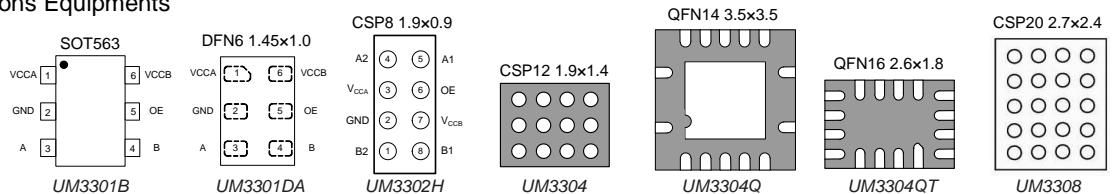

Product Selection Guide

EMI Filters

Audio/CRC EMI Filters

Part Number	Protected Lines	V _{RWM} (V) (Max)	R (Ω) (Typ)	C _J @ V _R =2.5V (pF)	f _{3db} (MHz) (Typ)	ESD (kV)		Package
						Contact	Air	
UM1002	2	5	1	15	-	±8	±15	SOT23-6
UM4401	4	5	100	10	150	±8	±15	DFN8 2.1×1.6
UM4411	4	5	100	10	150	±8	±15	DFN8 1.7×1.3
UM6401	6	5	100	10	150	±8	±15	DFN12 3.0×1.6
UM6411	6	5	100	10	150	±8	±15	DFN12 2.5×1.3
UM8401	8	5	100	15	150	±8	±15	DFN16 4.0×1.6
UM8411	8	5	100	10	150	±8	±15	DFN16 3.3×1.3

CLC EMI Filters

Part Number	Protected Lines	V _{RWM} (V) (Max)	L (nH) (Typ)	DCR (Ω) (Typ)	C _J @ V _R =2.5V (pF)	f _{3db} (MHz) (Typ)	ESD (kV)		Package
							Contact	Air	
UM4601	4	5	17	10	15	150	±8	±15	DFN8 2.0×2.0
UM4611	4	5	17	10	15	150	±8	±15	DFN8 1.7×1.3
UM8601	8	5	17	10	15	150	±8	±15	DFN16 4.0×1.6
UM8611	8	5	17	10	15	150	±8	±15	DFN16 3.3×1.3
UM4501	4	5	17	10	12	250	±8	±15	DFN8 2.0×2.0
UM4511	4	5	17	10	12	250	±8	±15	DFN8 1.7×1.3
UM6501	6	5	17	10	12	250	±8	±15	DFN12 3.0×1.6
UM8501	8	5	17	10	12	250	±8	±15	DFN16 4.0×1.6
UM8511	8	5	17	10	12	250	±8	±15	DFN16 3.3×1.3
UM4701	4	5	19	18	12	150	±8	±15	DFN8 2.0×2.0
UM4711	4	5	19	18	12	150	±8	±15	DFN8 1.7×1.3
UM8701	8	5	19	18	12	150	±8	±15	DFN16 4.0×1.6
UM8711	8	5	19	18	12	150	±8	±15	DFN16 3.3×1.3

Product Selection Guide

ESD Protection

USB Port and Ethernet Port Protection

Part Number	Description	Protected Lines	V _{RWM} (V) (Max)	C _J @ V _R =0V, I/O Pin to GND (pF) (Max)	ESD (kV)		Package
					Contact	Air	
UM5202EEDF	Unidirection	2	5	2	±8	±15	SOT143
UM5204EEExF	Unidirection	4	5	2	±8	±15	SOT363 SOT563 SOT23-6
UM5204EECD	Unidirection	4	5	2	±8	±15	SOT23-6
UM5204EECE	Unidirection	4	5	2	±8	±15	SOT23-6
UM5304EEExF	Unidirection	4	5	2	±8	±15	SOT363 SOT563 SOT23-6
*UM5404EECF	Unidirection for Ethernet 10/100	4	5	2	±8	±15	SOT23-6

General Purpose Protection

Part Number	Description	Protected Lines	V _{RWM} (V) (Max)	C _J (pF) @ V _R =0V (Typ)	ESD (kV)		Package
					Contact	Air	
UM5055	Unidirection	1	5	40	±8	±15	SOD523
UM5059	Unidirection	1	5	40	±8	±15	DFN2 1.0×0.6
UM5059T	Unidirection	1	5	90	±30	±30	DFN2 1.0×0.6
UM5060	Bi-direction	1	5	40	±30	±30	SOD523
UM5080	Bi-direction	1	5	25	±30	±30	DFN2 1.0×0.6
UM5080T	Bi-direction	1	5	45	±30	±30	DFN2 1.0×0.6
UESD6V8L1F	Unidirection	1	5	17	±8	±15	DFN2 1.0×0.6
UM5051DA	Unidirection	1	5	19	±25	±30	DFN2 0.6×0.3
UM5052DA	Bi-direction	1	5	7	±30	±30	DFN2 0.6×0.3
SM05	Unidirection	2	5	50	±8	±15	SOT23-3
UM5062	Unidirection	2	5	40	±8	±15	QFN3 1.4×1.1
UESD6V8S2B	Unidirection	2	5	40	±8	±15	SOT523
UESD54B	Unidirection	4	5	40	±8	±15	SOT353
UESD55B	Unidirection	4	5	40	±8	±15	SOT563
UESD64B	Unidirection	4	5	40	±8	±15	SOT553
UESD16V8S4C	Unidirection	4	12	20	±8	±15	SOT23-6
UESD6V8L4A	Unidirection	4	5	20	±8	±15	SOT353
UESD6V8L4B	Unidirection	4	5	20	±8	±15	SOT553
UESD56B	Unidirection	5	5	40	±8	±15	SOT563
UESD6V85CT36	Unidirection	5	5	40	±8	±15	SOT363
UESD6V8L5A6	Unidirection	5	5	20	±8	±15	SOT363
UESD6V8L5B	Unidirection	5	5	18	±8	±15	SOT563
UESD57B	Unidirection	6	5	40	±8	±15	DFN6 1.6×1.6

*: Future product, contact factory.

Product Selection Guide

ESD Protection

High and Medium Working Voltage

Part Number	Description	Protected Lines	V_{RWM} (V) (Max)	$C_J @ V_R=0V$ (pF) (Typ)	ESD (kV)		Package
					Contact	Air	
SM12	Unidirection	2	12	20	±8	±15	SOT23-3
SM15	Unidirection	2	15	20	±8	±15	SOT23-3
UM5075	Unidirection	1	7	40	±8	±15	SOD523
UM5079	Unidirection	1	7	40	±8	±15	DFN2 1.0×0.6
UM50125	Unidirection	1	12	20	±30	±30	SOD523
UM50129	Unidirection	1	12	20	±30	±30	DFN2 1.0×0.6
UESD16V8S4C	Unidirection	4	12	20	±30	±30	DFN2 1.0×0.6

ESD Protection

Single Line ESD Protection Diode in DFN0603 Package

UM5051DA/UM5052DA

Key Features

- UM5051DA ESD Protection Class:
IEC 61000-4-2 ±30kV (Air), ±25kV (Contact)
- UM5052DA ESD Protection Class:
IEC 61000-4-2 ±30kV (Air), ±30kV (Contact)
- Protect One I/O or Power Line
- Low Clamping Voltage
- Stand-Off Voltage: 5V
- Low Leakage Current
- Ultra Small 0.6mm×0.3mm Outline

Applications

- Cell Phone Handsets and Accessories
- Personal Digital Assistants (PDAs)
- Notebooks, Desktops and Servers
- Portable Instrumentations
- Digital Cameras
- MP3 Players

The UM5051DA/UM5052DA ESD protection diode is designed to replace multilayer varistors (MLVs) in portable applications such as cell phones, notebook computers and PDAs. The devices are available in DFN2 0.6mm×0.3mm package with working voltage of 5 volt. It gives designer the flexibility to protect one unidirectional (UM5051DA) or one bi-directional (UM5052DA) line in applications where arrays are not practical. Additionally, it may be “sprinkled” around the board in applications where board space is at a premium.

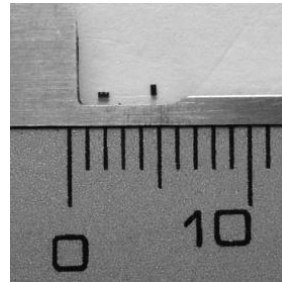

Ultra Small DFN2 0.6x0.3 Package

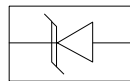

UM5051DA Pin Configuration

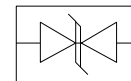

UM5052DA Pin Configuration

Sales Contact

Union Semiconductor Sales Office

Union Semiconductor, Inc.

Add: 5201 Great America Pkwy, Suite 320, Santa Clara, CA 95054

Tel: +1-855-668-7711

E-mail: sales@union-ic.com

Union Semiconductor (Shanghai) Ltd.

Add: Room 606, No. 570 Shengxia Road, Zhangjiang Hi-Tech Park, Shanghai

Tel: (86)21-51093966

Fax: (86)21-51026018

E-mail: sales@union-ic.com

Union Semiconductor (Shenzhen) Ltd.

Add: Room 1202, Anhui Building, No. 6007 Shennan Road, Futian District, Shenzhen

Tel: (86)755-88309242/88309243/88309244

Fax: (86)755-88309242-808

E-mail: sales@union-ic.com

Union Semiconductor (HK) Ltd.

Add: Unit 202, No.8 Science Park West Avenue, Hong Kong Science & Technology Park, NT, Hong Kong

Tel: (852)22107006

Fax: (852)83431122

E-mail: sales@union-ic.com

Union Semiconductor, Beijing Office

Tel: (86)21-68367050

E-mail: sales@union-ic.com

Union Semiconductor, Qingdao Office

Tel: (86)21-68367050

E-mail: sales@union-ic.com



CONTACT US

UNION SEMICONDUCTOR, INCORPORATED.

Add:Unit 606,No.570 Shengxia Road,Zhangjiang Hi-Tech Park,Shanghai

Zip Code:201210

Tel:86-21-51093966

Fax:86-21-51026018

Website:www.union-ic.com