

$\pm 70V$ Fault-Protected 4.5V to 5.5V RS-485 Transceivers

UM3783S8 SOP8

1 Description

The UM3783S8 is $\pm 70V$ fault-protected, half-duplex, RS-485 transceiver operating on a single 4.5V to 5.5V supply voltage. Bus interface pins are protected against overvoltage conditions during all modes of operation ensuring robust communication in rugged industrial environments.

The device feature integrated IEC ESD protection, eliminating the need for external system-level protection components. Extended $\pm 15V$ input common-mode range guarantees reliable data communication over longer cable run lengths and/or in the presence of large ground loop voltages. Enhanced 250mV receiver hysteresis ensures high noise rejection. In addition, the receiver fail-safe feature guarantees a logic high when the inputs are open or shorted together.

The UM3783S8 is available in SOP8 package for space-constrained applications. The device is characterized over ambient free-air temperatures from $-40\text{ }^{\circ}\text{C}$ to $125\text{ }^{\circ}\text{C}$.

2 Applications

- Motor drives
- Factory automation and control
- HVAC systems
- Building automation
- Grid infrastructure
- Electricity meters
- Process analytics
- Video surveillance

3 Features

- Meets or exceeds the requirements of the TIA/EIA-485A standards
- 4.5V to 5.5V supply voltage
- Differential output exceeds 2.1 V for PROFIBUS compatibility with 5V supply
- Bus I/O protection $\pm 70V$ DC bus fault
- Half-duplex device available in 500 kbps
- Extended ambient temperature range: $-40\text{ }^{\circ}\text{C}$ to $125\text{ }^{\circ}\text{C}$
- Extended operational common-mode range: $\pm 15\text{ V}$
- Open, short, and idle bus failsafe
- Thermal shutdown
- 1/8 unit load (up to 256 bus nodes)
- Small SOP8 package

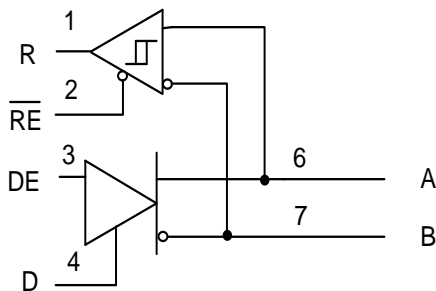

UM3783S8 Simplified Schematic

4 Ordering Information

Part Number	Mark Code	Package Type	Shipping Qty
UM3783S8	UM3783S8	SOP8	3000pcs/13Inch Tape & Reel

5 Pin Configuration and Function

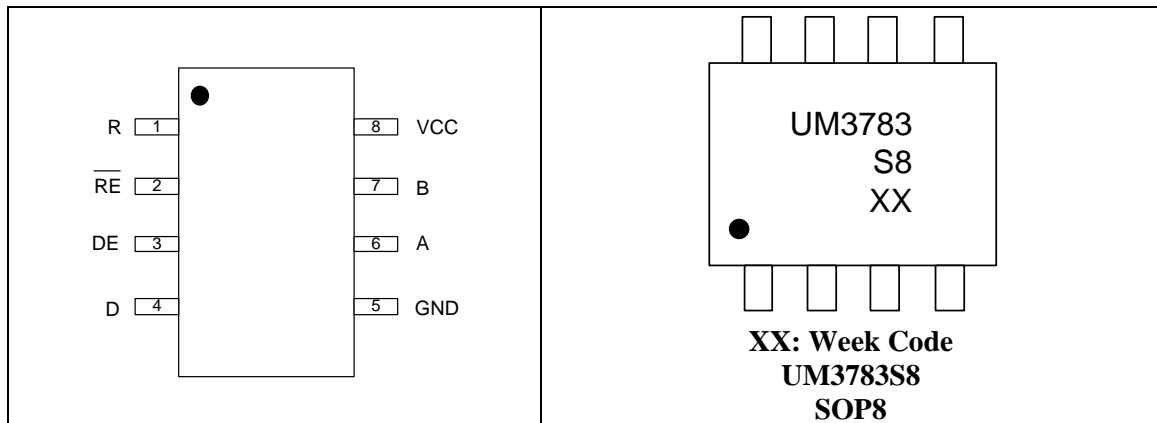

Table 5-1. Pin Functions

Pin No.	Pin Name	Function
1	R	Receive data output
2	\overline{RE}	Receiver enable, active low
3	DE	Driver enable, active high
4	D	Driver data input
5	GND	Local device ground
6	A	Driver output or receiver input (complementary to B)
7	B	Driver output or receiver input (complementary to A)
8	VCC	Supply voltage

6 Specifications

6.1 Recommended Operating Conditions

Symbol	Parameter	Conditions	Min	Typ	Max	Unit
V _{CC}	Supply Voltage		4.5		5.5	V
V _I	Input voltage at any bus terminal (separately or common mode)	Note1	-15		15	V
V _{ID}	Differential input voltage		-15		15	V
I _O	Output current, driver		-60		60	mA
I _{OR}	Output current, receiver		-8		8	mA
R _L	Differential load resistance		54	60		Ω
1/ t _{UI}	Signaling rate				500	kbps
T _A	Operating free-air temperature (see application section for thermal information)		-40		125	°C
T _J	Junction temperature		-40		150	°C

Note 1: The algebraic convention, in which the least positive (most negative) limit is designated as minimum is used in this data sheet.

6.2 Absolute Maximum Ratings (Note 1)

Symbol	Parameter	Conditions	Min	Typ	Max	Unit
V _{CC}	Supply voltage		-0.5		6.5	V
V _I	Voltage on A, B		-70		70	V
	Voltage on any logic pin (D, DE, RE)		-0.3		5.7	V
I _O	RXD output current		-24		24	mA
T _{STG}	Storage temperature		-55		150	°C

Note 1: Operation outside the Absolute Maximum Ratings may cause permanent device damage. Absolute maximum ratings do not imply functional operation of the device at these or any other conditions beyond those listed under Recommended Operating Conditions. If briefly operating outside the Recommended Operating Conditions but within the Absolute Maximum Ratings, the device may not sustain damage, but it may not be fully functional. Operating the device in this manner may affect device reliability, functionality, performance, and shorten the device lifetime.

6.3 Electrical Characteristics (Static)

over operating free-air temperature range (unless otherwise noted). All typical values are at 25 °C and supply voltage of $V_{CC} = 5\text{ V}$.

Symbol	Parameter	Conditions	Min	Typ	Max	Unit
Supply						
I_{CC}	Supply current	$\overline{RE} = 0\text{ V}$, $DE = V_{CC}$, No load (Driver and receiver enabled)		4.5	6.6	mA
		$\overline{RE} = V_{CC}$, $DE = V_{CC}$, No load (Driver enabled, receiver disabled)		3.5	5.4	mA
		$\overline{RE} = 0\text{ V}$, $DE = 0\text{ V}$, No load (Driver disabled, receiver enabled)		1.8	2.4	mA
		$\overline{RE} = V_{CC}$, $DE = 0\text{ V}$, D = open, No load (Driver and receiver disabled)		0.5	2	μA
Driver						
$ V_{OD} $	Driver differential output voltage magnitude	$R_L = 60\ \Omega$, $-25\text{ V} \leq V_{TEST} \leq 25\text{ V}$, See Figure 7-1	1.5	3.3		V
		$R_L = 60\ \Omega$, $-25\text{ V} \leq V_{TEST} \leq 25\text{ V}$, $4.5\text{ V} \leq V_{CC} \leq 5.5\text{ V}$, See Figure 7-1	2.1	3.3		V
		$R_L = 100\ \Omega$, See Figure 7-2	2	4		V
		$R_L = 54\ \Omega$, See Figure 7-2	1.5	3.3		V
$\Delta V_{OD} $	Change in magnitude of driver differential output voltage	$R_L = 54\ \Omega$ or $100\ \Omega$ See Figure 7-2	-50		50	mV
V_{OC}	Common-mode output voltage	$R_L = 54\ \Omega$ or $100\ \Omega$ See Figure 7-2	1	$V_{CC}/2$	3	V
$V_{OC(SS)}$	Steady-state common-mode output voltage	$R_L = 54\ \Omega$ or $100\ \Omega$ See Figure 7-2	-50		50	mV
I_{OS}	Short-circuit output current	$DE = V_{CC}$, $-70\text{ V} \leq (V_A$ or $V_B) \leq 70\text{ V}$	-250		250	mA
Receiver						
I_I	Bus input current	$DE = 0\text{ V}$, $V_{CC} = 0\text{ V}$ or 5.5 V , $V_I = 12\text{ V}$		75	125	μA

6.3 Electrical Characteristics (Static)---continued (Note 1)

over operating free-air temperature range (unless otherwise noted). All typical values are at 25 °C and supply voltage of $V_{CC}=5\text{ V}$.

Symbol	Parameter	Conditions	Min	Typ	Max	Unit
		DE = 0V, $V_{CC} = 0\text{V}$ or 5.5V, $V_I = 25\text{V}$		150	250	μA
		DE = 0V, $V_{CC} = 0\text{V}$ or 5.5V, $V_I = -7\text{V}$	-100	-40		
		DE = 0V, $V_{CC} = 0\text{V}$ or 5.5V, $V_I = -25\text{V}$	-250	-150		
V_{TH+}	Positive-going input threshold voltage	Over common-mode range of $\pm 15\text{ V}$	40	125	200	mV
V_{TH-}	Negative-going input threshold voltage		-200	-125	-40	
V_{HYS}	Input hysteresis			250		
$C_{A,B}$	Input differential capacitance	Measured between A and B, $f = 1\text{ MHz}$		50		pF
V_{OH}	Output high voltage	$I_{OH} = -8\text{ mA}$	$V_{CC}-0.4$	$V_{CC}-0.2$		V
V_{OL}	Output low voltage	$I_{OL} = 8\text{ mA}$		0.25	0.4	V
I_{OZ}	Output high-impedance current	$V_O = 0\text{ V}$ or V_{CC} , $\overline{RE} = V_{CC}$	-1		1	μA
Logic						
V_{IH}	Input High Voltage	DE, DI, \overline{RE}	2			V
V_{IL}	Input low Voltage	DE, DI, \overline{RE}			0.8	V
I_I	Input current on DE pin	$4.5\text{ V} \leq V_{CC} \leq 5.5\text{ V}$, $0\text{ V} \leq V_{IN} \leq V_{CC}\text{ V}$			5	μA
	Input current on D, \overline{RE} pin	$4.5\text{ V} \leq V_{CC} \leq 5.5\text{ V}$, $0\text{ V} \leq V_{IN} \leq V_{CC}\text{ V}$	-5			μA
Thermal Protection						
T_{SD}	Thermal shutdown threshold	Temperature rising	150	170		°C
T_{HYS}	Thermal shutdown hysteresis			10		°C

6.4 Electrical Characteristics (Dynamic) (Note 1)

over recommended operating conditions. All typical values are at 25 °C and supply voltage of $V_{CC}=5V$.

Symbol	Parameter	Conditions	Min	Typ	Max	Unit
Driver						
t_R, t_F	Driver differential output rise/fall time	$R_L = 54 \Omega, C_L = 50 \text{ pF}$, see Figure 7-3	240	280	600	ns
t_{PHL}, t_{PLH}	Driver propagation delay time			275	350	ns
$t_{SK(P)}$	Driver differential output pulse skew, $ t_{PHL} - t_{PLH} $				10	ns
t_{PHZ}, t_{PLZ}	Disable time	See Figure 7-4 and Figure 7-5		45	95	ns
t_{PZH}, t_{PZL}	Enable time	$\overline{RE} = 0 \text{ V}$, See Figure 7-4 and Figure 7-5		175	270	ns
		$\overline{RE} = V_{CC}$, See Figure 7-4 and Figure 7-5		1.5	4	μs
t_{SD}	Time to shutdown	$\overline{RE} = V_{CC}$, See Figure 7-4 and Figure 7-5	50		500	ns
Receiver						
t_R, t_F	Receiver output rise/fall time	$C_L = 15 \text{ pF}$, see Figure 7-6		13	20	ns
t_{PHL}, t_{PLH}	Receiver propagation delay time			50	80	ns
$t_{SK(P)}$	Receiver output pulse skew, $ t_{PHL} - t_{PLH} $				7	ns
t_{PHZ}, t_{PLZ}	Receiver disable time			30	40	ns
$t_{PZL(1)}, t_{PZH(1)}$	Receiver enable time	$DE = V_{CC}$, see Figure 7-7		90	120	ns
$t_{PZL(2)}, t_{PZH(2)}$		$DE = 0 \text{ V}$, see Figure 7-8		2	4	μs
$t_{D(OFS)}$	Delay to enter fail-safe operation	$C_L = 15 \text{ pF}$, see Figure 7-9	7	10	18	μs
$t_{D(FSO)}$	Delay to exit fail-safe operation		35	45	60	ns
t_{SD}	Time to shutdown	$DE = 0 \text{ V}$, see Figure 7-8	50		500	ns

7 Parameter Measurement Information

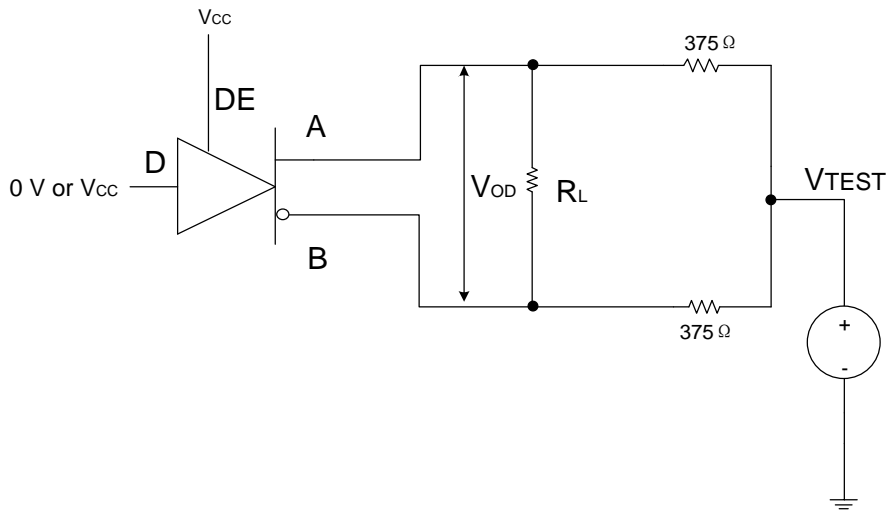

Figure 7-1. Measurement of Driver Differential Output Voltage With Common-Mode Load

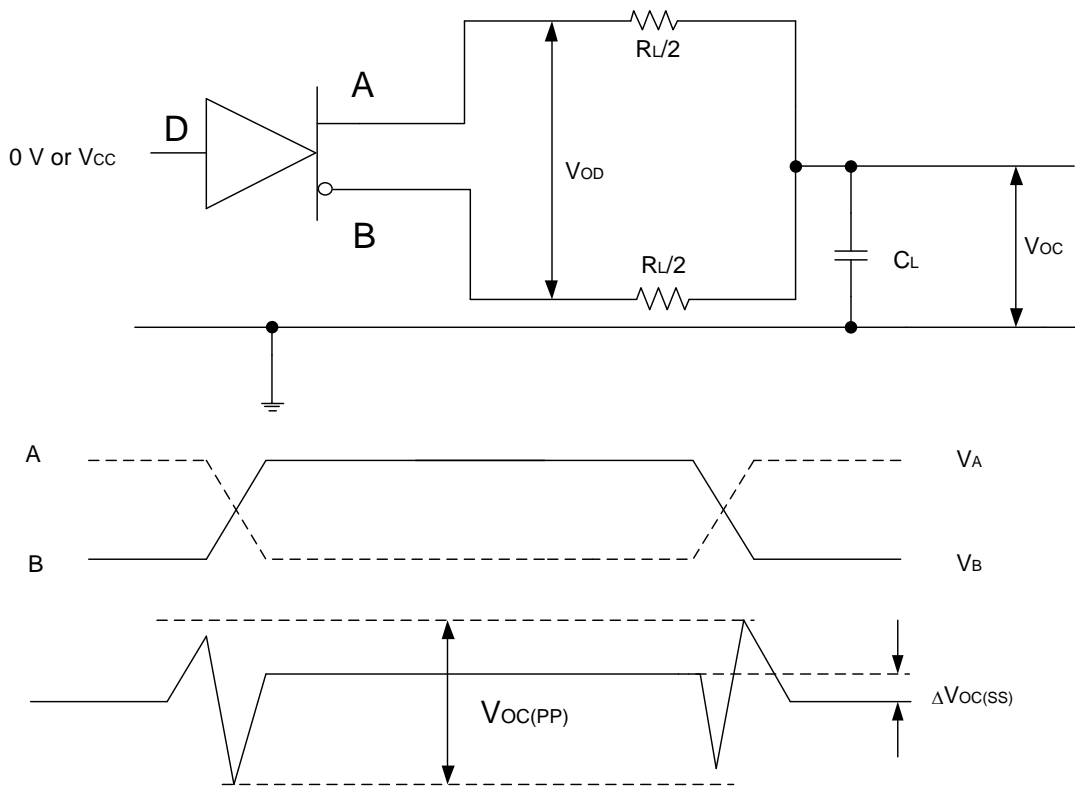

Figure 7-2. Measurement of Driver Differential and Common-Mode Output With RS-485 Load

7 Parameter Measurement Information (continued)

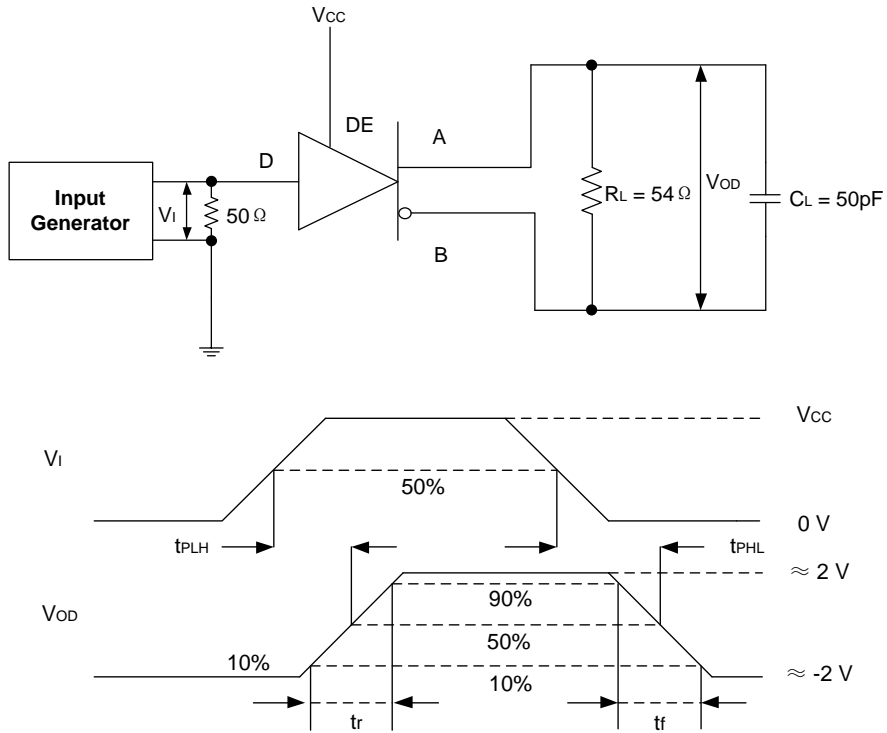

Figure 7-3. Measurement of Driver Differential Output Rise and Fall Times and Propagation Delays

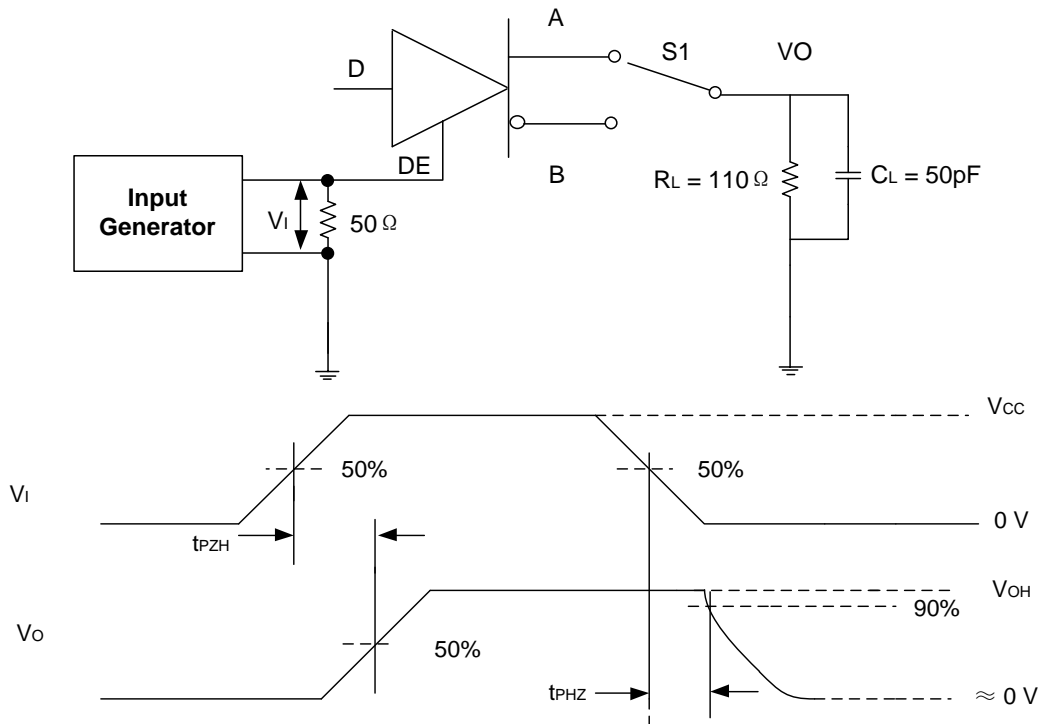

Figure 7-4. Measurement of Driver Enable and Disable Times With Active High Output and Pull-Down Load

7 Parameter Measurement Information (continued)

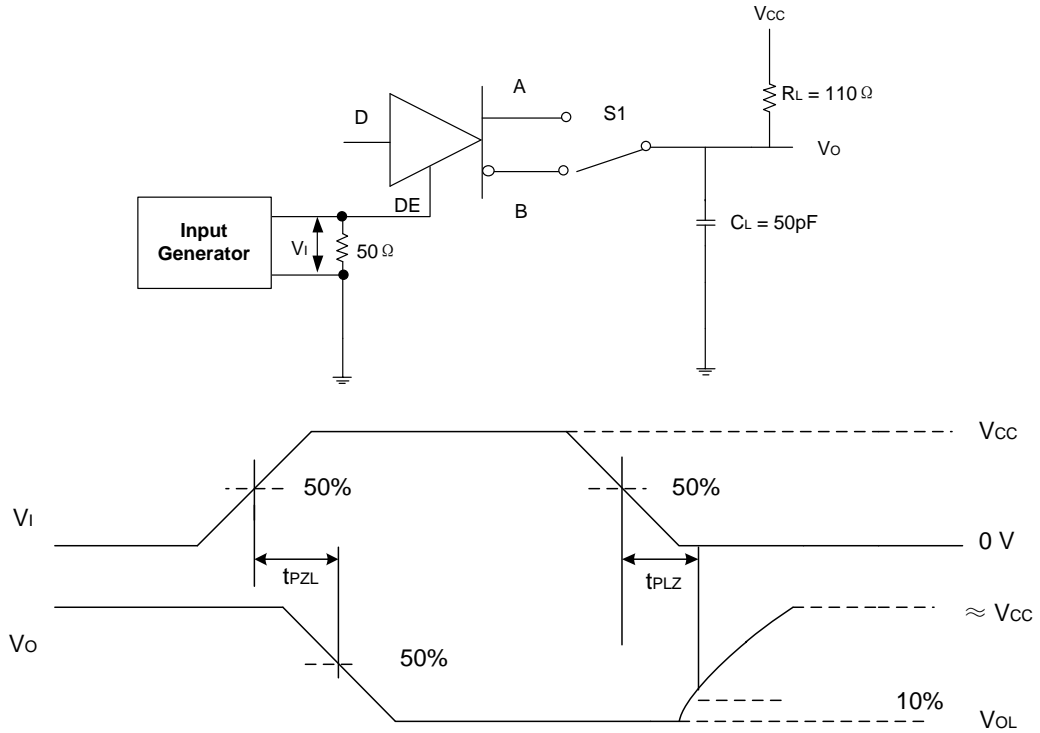

Figure 7-5. Measurement of Driver Enable and Disable Times With Active Low Output and Pull-up Load

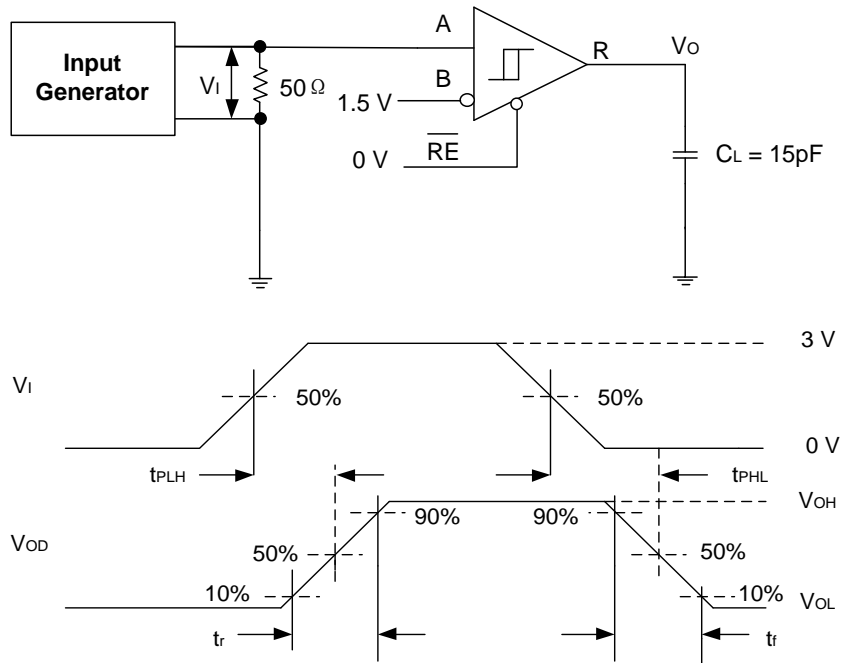

Figure 7-6. Measurement of Receiver Output Rise and Fall Times and Propagation Delays

7 Parameter Measurement Information (continued)

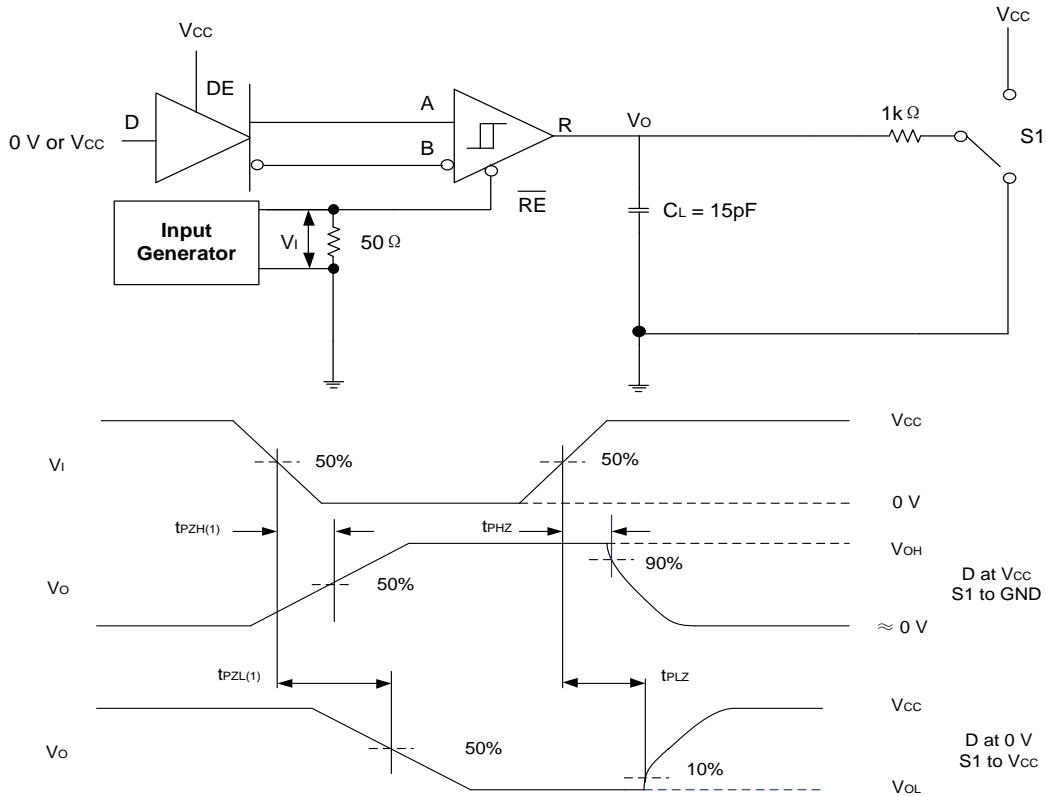

Figure 7-7. Measurement of Receiver Enable/Disable Times With Driver Enabled

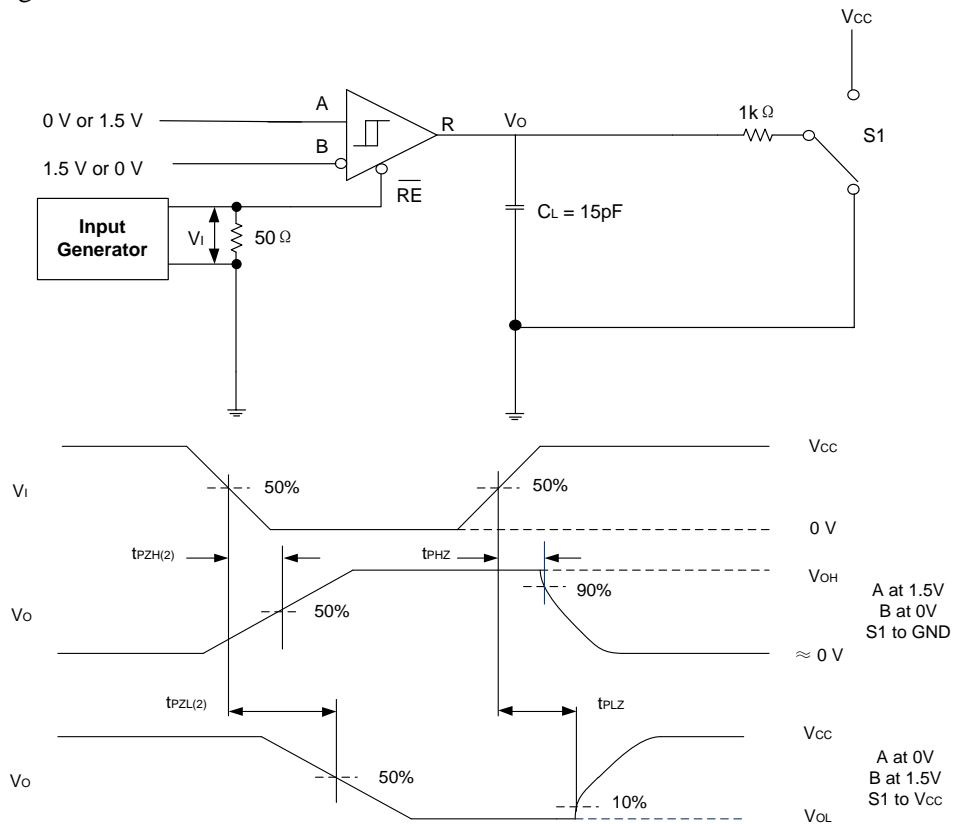

Figure 7-8. Measurement of Receiver Enable Times With Driver Disabled

7 Parameter Measurement Information(continued)

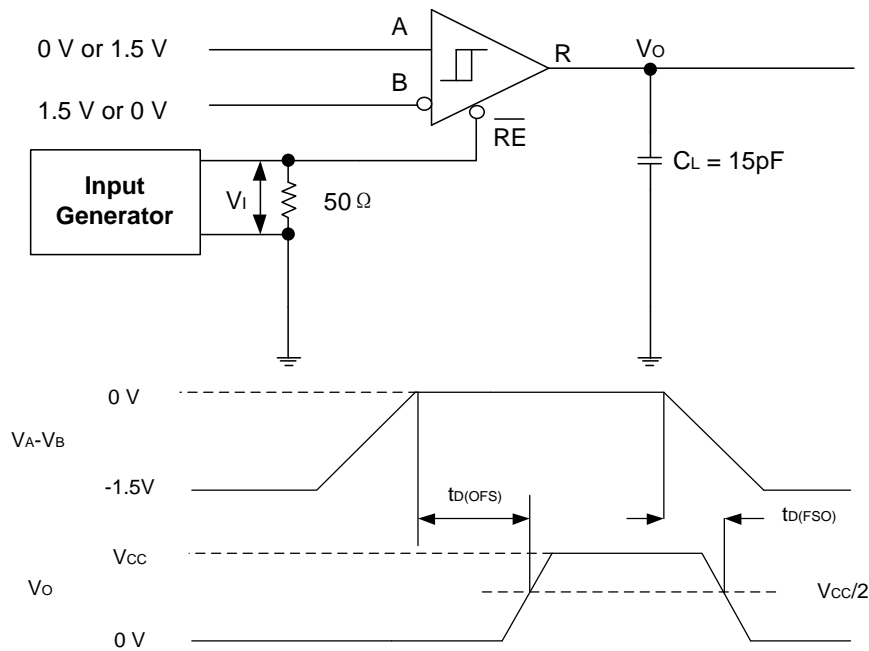

Figure 7-9. Measurement of Fail-Safe Delay

8 Detailed Description

8.1 Overview

The UM3783S8 is fault-protected, half duplex RS-485 transceivers available in speed grade suitable for data transmission up to 500 kbps. The device has active-high driver enables and active-low receiver enables. A shutdown current of less than 1 μ A can be achieved by disabling both driver and receiver.

8.2 Functional Block Diagram

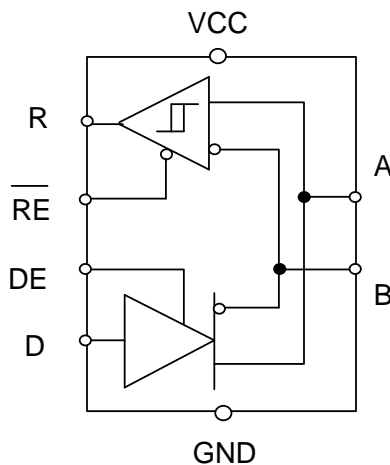

Figure 8-1. UM3783S8 Block Diagram

9 Feature Description

9.1 ± 70 -V Fault Protection

The UM3783S8 has extended bus fault protection compared to standard RS-485 devices. Transceivers that operate in rugged industrial environments are often exposed to voltage transients greater than the -7 V to +12 V defined by the TIA/EIA-485A standard. To protect against such conditions, the generic RS-485 devices with lower absolute maximum ratings requires expensive external protection components. To simplify system design and reduce overall system cost, the UM3783S8 are protected up to ± 70 V without the need for any external components.

9.2 Driver Overvoltage and Overcurrent Protection

The UM3783S8 drivers are protected against any DC supply shorts in the range of -70 V to +70 V. The device internally limits the short circuit current to ± 250 mA in order to comply with the TIA/EIA-485A standard. In addition, a fold-back current limiting circuit further reduces the driver short circuit current to less than ± 5 mA if the output fault voltage exceeds $|\pm 15$ V|.

The device features thermal shutdown protection that disables the driver and the receiver if the junction temperature exceeds the T_{SHDN} threshold due to excessive power dissipation.

9.3 Receiver Fail-Safe Operation

The receivers are fail-safe to invalid bus states caused by the following:

- Open bus conditions, such as a disconnected connector
- Shorted bus conditions, such as cable damage shorting the twisted-pair together
- Idle bus conditions that occur when no driver on the bus is actively driving

9.4 Low-Power Shutdown Mode

Driving DE low and $\overline{\text{RE}}$ high for longer than 500 ns puts the devices into the shutdown mode. If either DE goes high or $\overline{\text{RE}}$ goes low, the counters reset. The devices does not enter the shutdown mode if the enable pins are in disable state for less than 50 ns. This feature prevents the devices from accidentally going into shutdown mode due to skew between DE and $\overline{\text{RE}}$.

9.5 Device Functional Modes

When the driver enable pin, DE, is logic high, the differential outputs A and B follow the logic states at data input D. A logic high at D causes A to turn high and B to turn low. In this case, the differential output voltage defined as $V_{\text{OD}} = V_{\text{A}} - V_{\text{B}}$ is positive. When D is low, the output states reverse: B turns high, A becomes low, and V_{OD} is negative.

When DE is low, both outputs turn high-impedance. In this condition, the logic state at D is irrelevant. The DE pin has an internal pull-down resistor to ground, thus when left open the driver is disabled (high-impedance) by default. The D pin has an internal pull-up resistor to V_{CC} , thus, when left open while the driver is enabled, output A turns high and B turns low.

Table 9-1. Driver Function Table

INPUT	ENABLE	OUTPUTS		FUNCTION
		A	B	
D	DE	A	B	
H	H	H	L	Actively drive bus high
L	H	L	H	Actively drive bus low
X	L	Z	Z	Driver disabled
X	OPEN	Z	Z	Driver disabled by default
OPEN	H	H	L	Actively drive bus high by default

When the receiver enable pin, \overline{RE} , is logic low, the receiver is enabled. When the differential input voltage defined as $V_{ID} = V_A - V_B$ is higher than the positive input threshold, V_{TH+} , the receiver output, R, turns high. When V_{ID} is lower than the negative input threshold, V_{TH-} , the receiver output, R, turns low. If V_{ID} is between V_{TH+} and V_{TH-} , the output is indeterminate.

When \overline{RE} is logic high or left open, the receiver output is high-impedance and the magnitude and polarity of V_{ID} are irrelevant. Internal biasing of the receiver inputs causes the output to go failsafe-high when the transceiver is disconnected from the bus (open-circuit), or the bus lines are shorted to one another (short-circuit), or the bus is not actively driven (idle bus).

Table 9-2. Driver Function Table

DIFFERENTIAL INPUT	ENABLE	OUTPUTS	FUNCTION
$V_{ID} = V_A - V_B$	\overline{RE}	R	
$V_{TH+} < V_{ID}$	L	H	Receive valid bus high
$V_{TH-} < V_{ID} < V_{TH+}$	L	N/A	Indeterminate bus state
$V_{ID} < V_{TH-}$	L	L	Receive valid bus low
X	H	Z	Receiver disabled
X	OPEN	Z	Receiver disabled by default
Open-circuit bus	L	H	Fail-safe high output
Short-circuit bus	L	H	Fail-safe high output
Idle (terminated) bus	L	H	Fail-safe high output

Package Information

SOP8

Outline Drawing

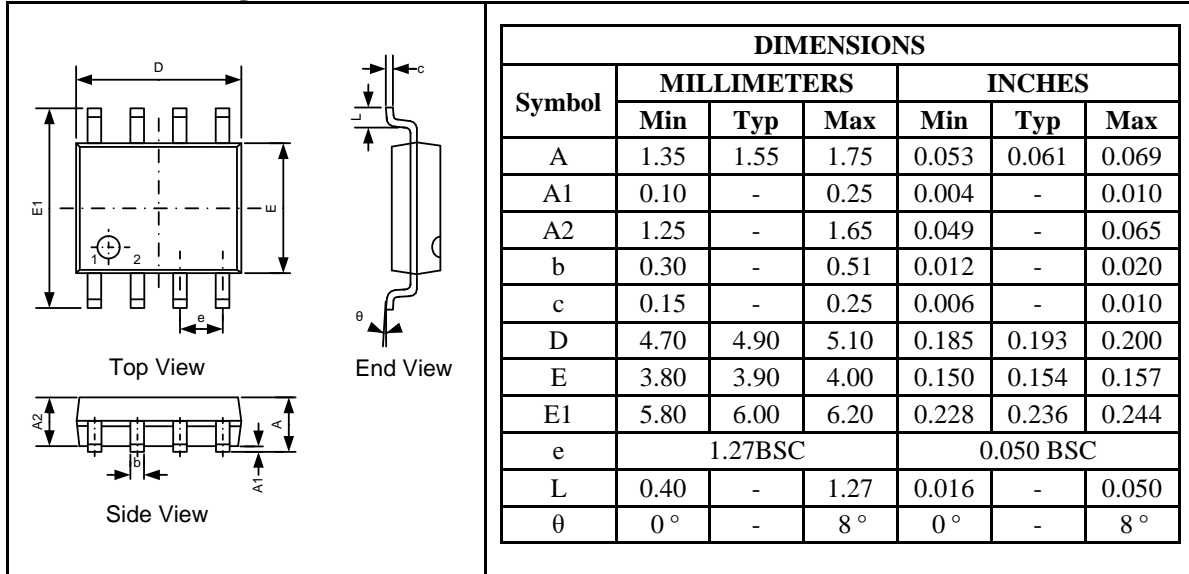

Land Pattern

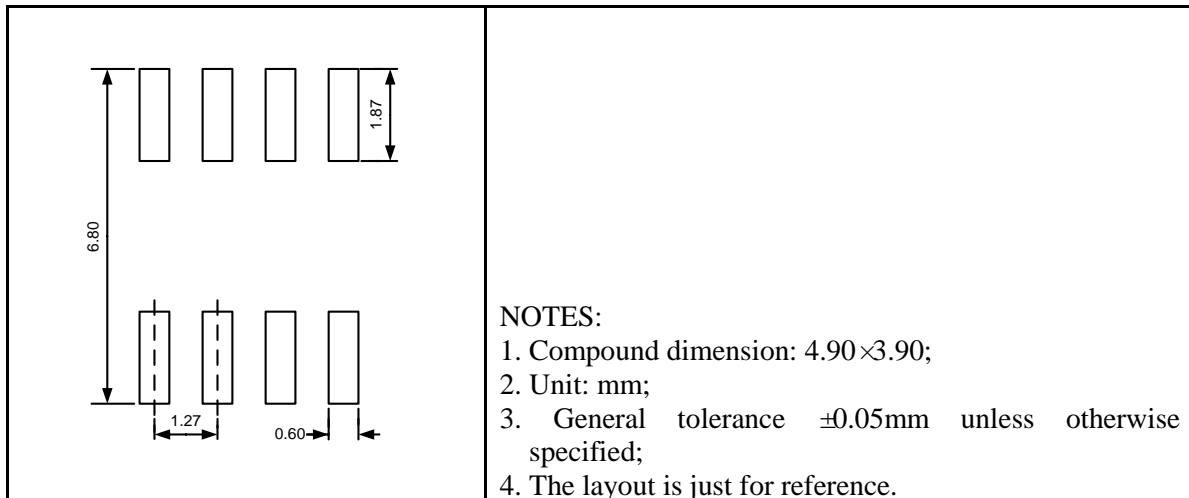

Packing Information

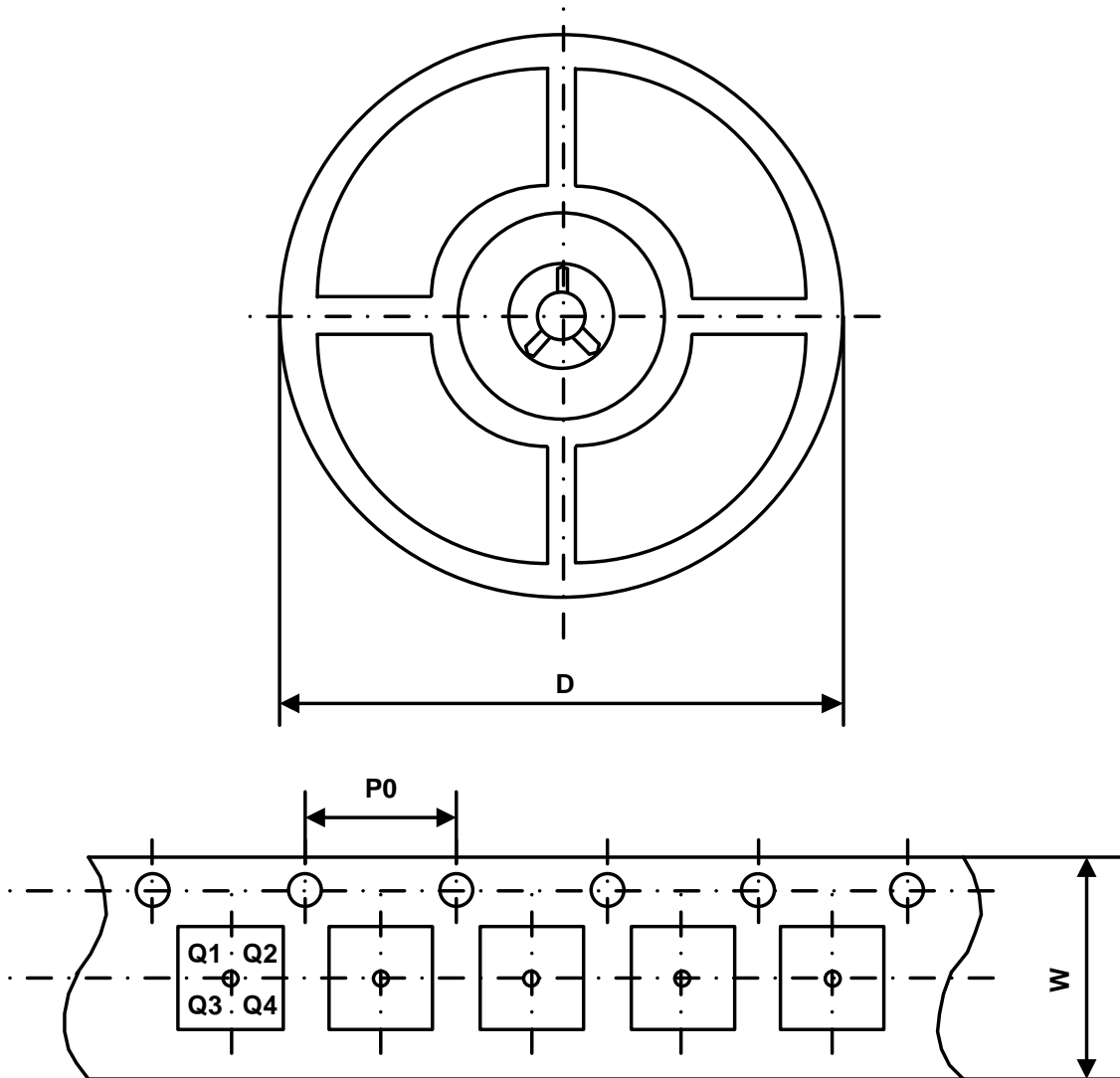

Part Number	Package Type	Carrier Width (W)	Pitch (P0)	Reel Size (D)	PIN 1 Quadrant
UM3783S8	SOP8	12 mm	4 mm	330 mm	Q1

GREEN COMPLIANCE

Union Semiconductor is committed to environmental excellence in all aspects of its operations including meeting or exceeding regulatory requirements with respect to the use of hazardous substances. Numerous successful programs have been implemented to reduce the use of hazardous substances and/or emissions.

All Union components are compliant with the RoHS directive, which helps to support customers in their compliance with environmental directives. For more green compliance information, please visit:

http://www.union-ic.com/index.aspx?cat_code=RoHSDeclaration

IMPORTANT NOTICE

The information in this document has been carefully reviewed and is believed to be accurate. Nonetheless, this document is subject to change without notice. Union assumes no responsibility for any inaccuracies that may be contained in this document, and makes no commitment to update or to keep current the contained information, or to notify a person or organization of any update. Union reserves the right to make changes, at any time, in order to improve reliability, function or design and to attempt to supply the best product possible.



Union Semiconductor, Inc

Add: Unit 606, No.570 Shengxia Road, Shanghai 201210

Tel: 021-51093966

Fax: 021-51026018

Website: www.union-ic.com