

Multi-Line ESD/EMI Protections for Signal Lines

UM8511 DFN16 3.3×1.3

General Description

The UM8511 is a (L-C) low pass filter array with integrated TVS diodes. It is designed to suppress unwanted EMI signals and provide electrostatic discharge (ESD) protection in portable electronic equipment. This device utilizes solid-state silicon-avalanche technology for superior clamping performance and DC electrical characteristics. It has been optimized for protection of signal lines in cellular phones and other portable electronics.

The device consists of identical circuits comprised of TVS diodes for ESD protection, and a C-L-C network for EMI filtering. A typical inductor value of 17nH and a capacitor value of 12pF are used to achieve 19dB minimum attenuation from 800MHz to 2.7GHz. The TVS diodes provide effective suppression of ESD voltages in excess of ±15kV (air discharge) and ±8kV (contact discharge) per IEC 61000-4-2, level 4.

The UM8511 is in a RoHS compliant DFN16 3.3×1.3 package. The leads are finished with lead-free. The small package makes it ideal for use in portable electronics such as cell phones, digital still cameras, and PDAs.

Applications

- Signal Lines Protection
- Cell Phone CCD Camera Lines
- Clamshell Cell Phones

Features

- Bidirectional EMI Filter with Integrated TVS for ESD Protection
- ESD Protection to IEC 61000-4-2 (ESD) Level 4, ±15kV (Air), ±8kV (Contact)
- Filter Performance: 19dB Minimum Attenuation from 800MHz to 2.7GHz
- TVS Working Voltage: 5V
- Inductor: 17nH (Typical)
- Capacitors: 12pF (Typical at $V_R=2.5V$)
- Protection and Filtering for Multi Lines
UM8511: Eight Lines

Ordering Information

Part Number	Working Voltage	Packaging Type	Channel	Marking Code	Shipping Qty
UM8511	5.0V	DFN16 3.3×1.3	8	8511	3000pcs /7Inch Tape & Reel

Pin Configurations

Top View

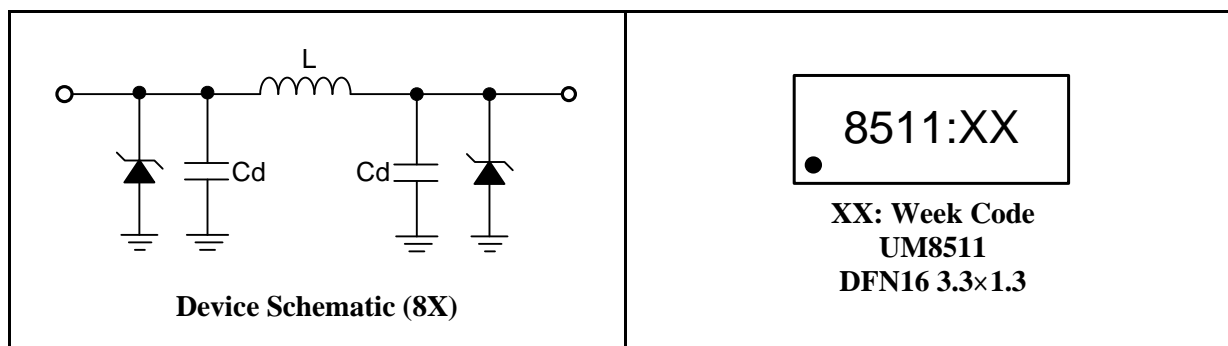

Absolute Maximum Ratings

Parameter	Symbol	Value	Unit
Junction Temperature	T_J	125	°C
Operating Temperature Range	T_{OP}	-40 to 85	°C
Storage Temperature Range	T_{STG}	-55 to 150	°C

Electrical Characteristics

($T_J = 25^\circ\text{C}$, unless otherwise noted)

Parameter	Symbol	Conditions	Min	Typ	Max	Unit
TVS Reverse Stand-Off Voltage	V_{RWM}				5	V
TVS Reverse Breakdown Voltage	V_{BR}	$I_T = 1\text{mA}$	6	8	10	V
TVS Reverse Leakage Current	I_R	$V_{RWM} = 3.3\text{V}$			0.1	μA
DC Resistance	R_{cc}			10		Ω
Filter Cut-Off Frequency	f_c	$Z_{source} = Z_{load} = 50\Omega$		250		MHZ
Inductance	L			17		nH
Capacitance	C_d	$V_R = 2.5\text{V}$, $f = 1\text{MHz}$		12		pF
Total Capacitance	C_{total}	Input to GND, Each Line $V_R = 2.5\text{V}$, $f = 1\text{MHz}$	19	24	29	pF
Stop Band Attenuation		800MHz to 2.7GHz		19		dB

Typical Operating Characteristics

Typical Insertion Loss

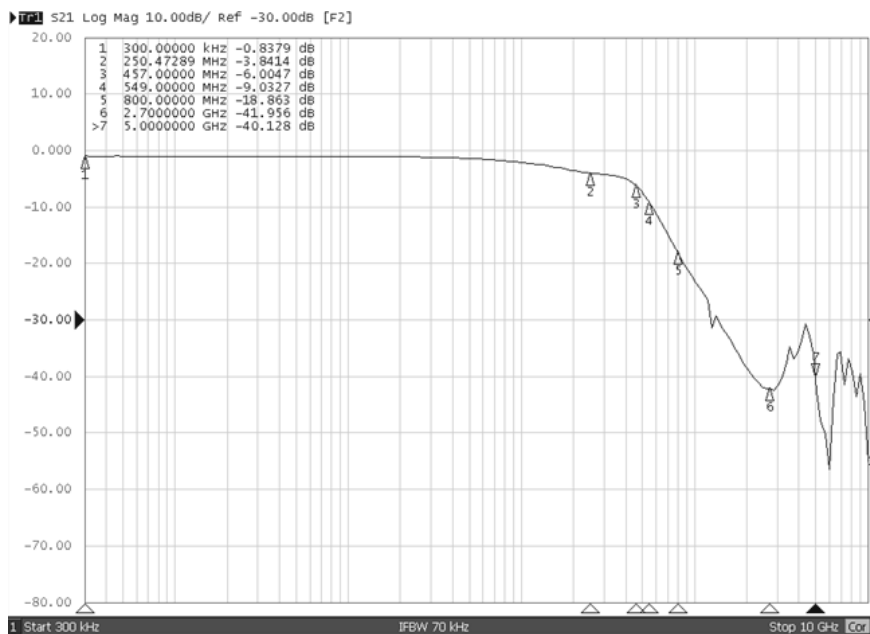

Analog Crosstalk

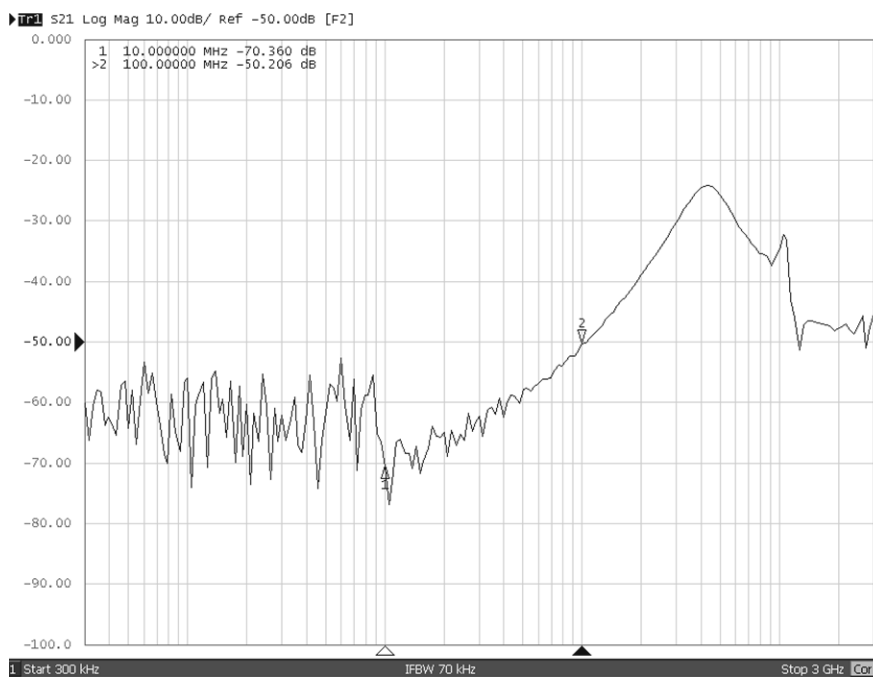

Applications Information

Insertion Loss

Insertion Loss (IL) is used to describe the transmission coefficient between two points in a circuit often described in terms of dB. When examining S parameters, S₂₁ is often described as insertion loss. Insertion Loss and S₂₁ will be used interchangeably from here on out. The insertion loss of a circuit with V_{OUT} and V_{IN} would be expressed as

$$IL=S_{21}(dB)=20\log(V_{OUT}/V_{IN})$$

The setup for measuring insertion loss in a 50Ω system is shown in Figure 1. It will be analyzed in a 50Ω environment, so the source impedance and load impedance is 50Ω. The transfer functions then can be analyzed in terms of insertion loss (S₂₁).

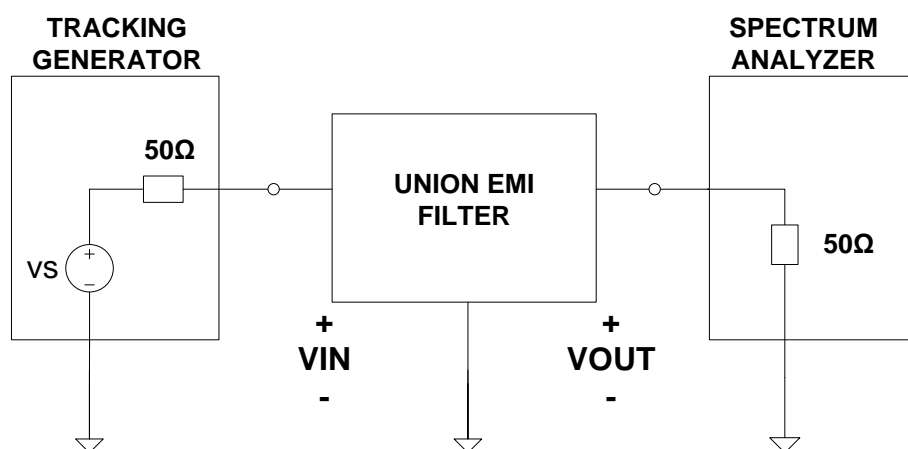

**Figure 1. Test Conditions: Source Impedance=50Ω
Load Impedance=50Ω
Input Power=0dBm**

Cut Off Frequency

Cut off frequency is the frequency at which the signal strength is 3.0dB less than that of its Pass Band, 3.0dB of attenuation equates to half the original signal power. The Pass Band is the range of frequencies that are allowed to “pass” through a filter with minimal attenuation. For our purposes it starts from DC and ends at the cut off frequency.

Device Connection

The UM8511 is comprised of identical circuits each consisting of a low pass filter for EMI suppression and dual TVS diodes for ESD protection. The device is in a 16-pin DFN package. Electrical connection is made to all the pins located at the bottom of the device. A center tab serves as the ground connection. The device has a flow through design for easy layout. All path lengths should be kept as short as possible to minimize the effects of parasitic inductance in the board traces.

Ground Connection Recommendation

Parasitic inductance (L) present in the board layout will affect the filtering performance of the device. As frequency (f) increases, the effect of the inductance becomes more dominant. This effect is given by Equation 1.

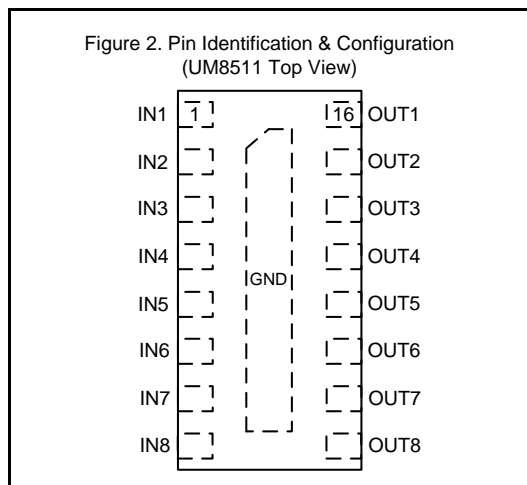

Pin	Identification
1-8	Input Lines
9-16	Output Lines
Center Tab	Ground

Equation 1: The Impedance of an Inductor at Frequency XLF

$$X_{LF}(L, f) = 2 \times \pi \times f \times L$$

Where:
 L= parasitic inductance in the PCB (H)
 f = frequency (Hz)

Package Information

UM8511: DFN16 3.3×1.3

Outline Drawing

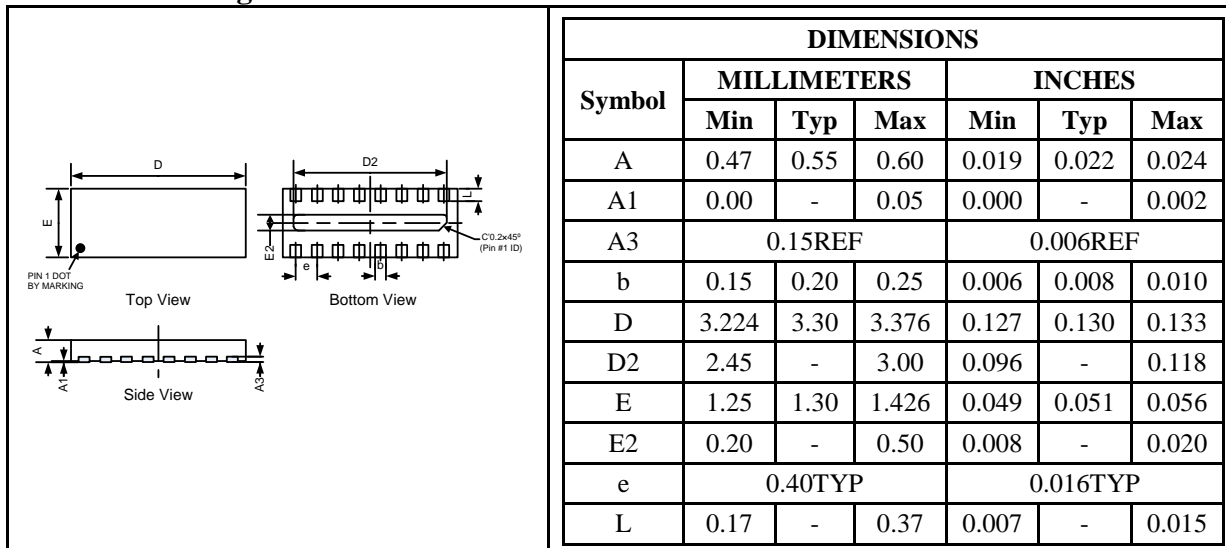

Land Pattern

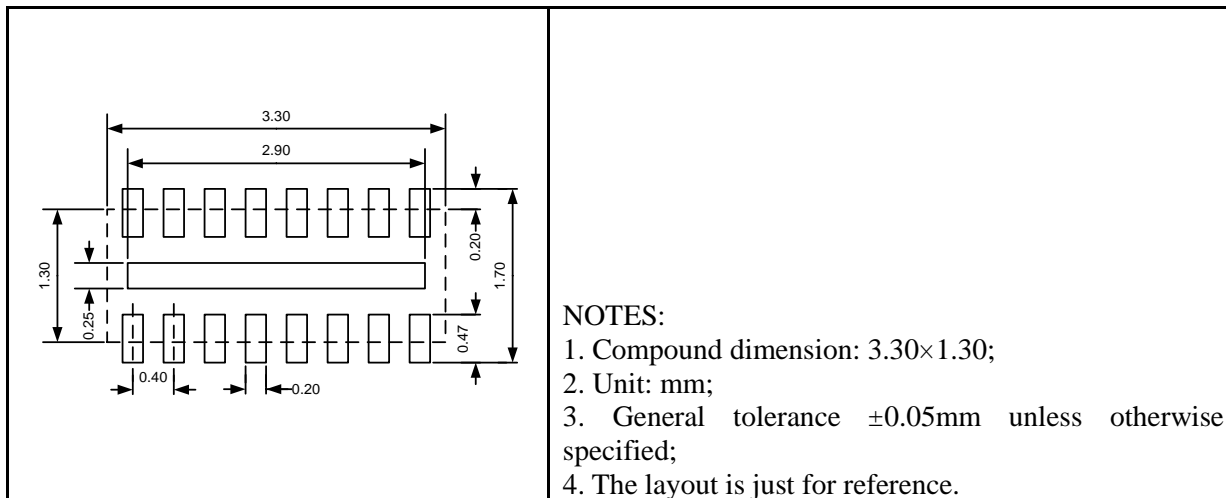

Tape and Reel Orientation



GREEN COMPLIANCE

Union Semiconductor is committed to environmental excellence in all aspects of its operations including meeting or exceeding regulatory requirements with respect to the use of hazardous substances. Numerous successful programs have been implemented to reduce the use of hazardous substances and/or emissions.

All Union components are compliant with the RoHS directive, which helps to support customers in their compliance with environmental directives. For more green compliance information, please visit:

http://www.union-ic.com/index.aspx?cat_code=RoHSDeclaration

IMPORTANT NOTICE

The information in this document has been carefully reviewed and is believed to be accurate. Nonetheless, this document is subject to change without notice. Union assumes no responsibility for any inaccuracies that may be contained in this document, and makes no commitment to update or to keep current the contained information, or to notify a person or organization of any update. Union reserves the right to make changes, at any time, in order to improve reliability, function or design and to attempt to supply the best product possible.



Union Semiconductor, Inc

Add: Unit 606, No.570 Shengxia Road, Shanghai 201210

Tel: 021-51093966

Fax: 021-51026018

Website: www.union-ic.com