8-Bit Dual-Supply Bus Transceiver With Configurable Voltage Translation and 3-State Outputs

UM74AVC8T245UO TSSOP24
UM74AVC8T245QB QFN24 3.5×5.5

1 Description

The UM74AVC8T245 is designed for asynchronous communication between two data buses. The device transmits data from the A bus to the B bus or from the B bus to the A bus, depending on the logic level of the direction-control input (DIR). The output-enable (\overline{OE}) input can be used to disable the outputs so the buses are effectively isolated. The UM74AVC8T245 is designed so that the control pins (DIR and \overline{OE}) are referenced to V_{CCA} voltage.

This device is fully specified for partial-power-down applications using I_{OFF} . The I_{OFF} circuitry disables the outputs, thus preventing damaging current backflow through the device when it is powered down. The V_{CC} isolation feature is designed so that if either V_{CC} input supply is below 100mV, all level shifter outputs are disabled and placed into a high impedance state. To put the device into the high-impedance state during power up or power down, tie \overline{OE} to V_{CC} through a pull-up resistor; the current-sinking capability of the driver determines the minimum value of the resistor.

The UM74AVC8T245 series are available in TSSOP24 and QFN24 3.5×5.5 packages.

2 Applications

- Enterprise and communications
- Industrial
- Personal electronics
- Wireless infrastructure
- Building automation
- Point of sale

3 Features

- Control inputs V_{IH}/V_{IL} levels are referenced to V_{CCA} voltage
- I_{OFF} supports partial power-down mode operation
- V_{CC} isolation feature – if either V_{CC} input is at GND, all are in the high-impedance state
- Fully configurable dual-rail design allows each port to operate over the full 1V to 3.6V power supply range
- Up to 400Mbps support when translating from 1.8V to 3.3V
- Latch-up performance exceeds 800 mA per JESD 78, Class II
- ESD protection exceeds JESD22
 - ±8kV Human body model (A114-A)
 - ±2kV Charged-device model

4 Logic Diagram

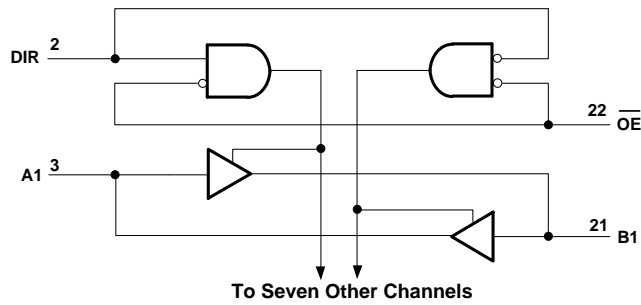

5 Ordering Information

Part Number	Mark Code	Package Type	Shipping Qty
UM74AVC8T245UO	8T245UO	TSSOP24	3000pcs/13Inch Tape & Reel
UM74AVC8T245QB	AVC8T245	QFN24 3.5×5.5	3000pcs/13Inch Tape & Reel

6 Pin Configuration and Function





	 <p style="text-align: center;">XX: Week Code UM74AVC8T245UO TSSOP24</p>
	 <p style="text-align: center;">XX: Week Code UM74AVC8T245QB QFN24 3.5×5.5</p>

Table 6-1. Pin Functions

Pin No.	Pin Name	Function
1	VCCA	A-port supply voltage. $1V \leq V_{CCA} \leq 3.6V$.
2	DIR	Direction-control signal. Referenced to V_{CCA} .
3	A1	Input/output A1. Referenced to V_{CCA} .
4	A2	Input/output A2. Referenced to V_{CCA} .
5	A3	Input/output A3. Referenced to V_{CCA} .
6	A4	Input/output A4. Referenced to V_{CCA} .
7	A5	Input/output A5. Referenced to V_{CCA} .
8	A6	Input/output A6. Referenced to V_{CCA} .
9	A7	Input/output A7. Referenced to V_{CCA} .
10	A8	Input/output A8. Referenced to V_{CCA} .
11-13	GND	Ground.
14	B8	Input/output B8. Referenced to V_{CCB} .
15	B7	Input/output B7. Referenced to V_{CCB} .
16	B6	Input/output B6. Referenced to V_{CCB} .
17	B5	Input/output B5. Referenced to V_{CCB} .
18	B4	Input/output B4. Referenced to V_{CCB} .
19	B3	Input/output B3. Referenced to V_{CCB} .
20	B2	Input/output B2. Referenced to V_{CCB} .
21	B1	Input/output B1. Referenced to V_{CCB} .
22	\overline{OE}	Output Enable. Pull to GND to enable all outputs. Pull to V_{CCA} to place all outputs in high-impedance mode. Referenced to V_{CCA} .
23-24	VCCB	B-port supply voltage. $1V \leq V_{CCB} \leq 3.6V$.

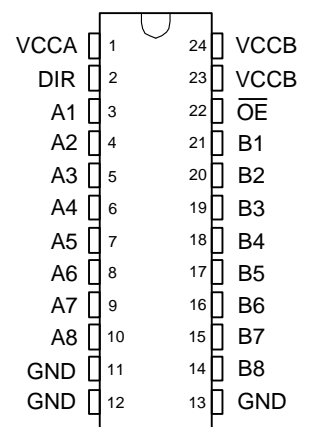
7 Specifications

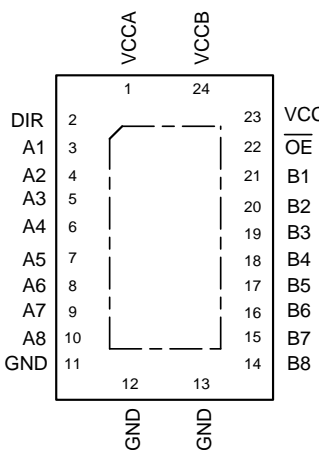
7.1 Absolute Maximum Ratings (Note 1)

Symbol	Parameter		Value	Unit
V _{CCA}	Supply Voltage		-0.5 to +4.6	V
V _{CCB}	Supply Voltage		-0.5 to +4.6	V
V _I	Input Voltage (Note 2)	A ports	-0.5 to +4.6	V
		B ports	-0.5 to +4.6	
		Control inputs	-0.5 to +4.6	
V _O	Voltage applied to any output in the high-impedance or Power-Off State (Note 2)	A ports	-0.5 to +4.6	V
		B ports	-0.5 to +4.6	
V _O	Voltage Range Applied to Any Output in the High or Low State (Note 2, 3)	A ports	-0.5 to (V _{CCA} +0.5)	V
		B ports	-0.5 to (V _{CCB} +0.5)	
V _{ESD}	Human body model (HBM)	All pins	±8	kV
	Charged device model (CDM)	All pins	±2	kV
I _{IK}	Input clamp current	V _I <0	-50	mA
I _{OK}	Output clamp current	V _O <0	-50	mA
I _O	Continuous Output Current		±50	mA
	Continuous Current through V _{CCA} , V _{CCB} , or GND		±100	mA
T _J	Operating Junction Temperature		-40 to +150	°C
T _{STG}	Storage Temperature		-65 to +150	°C

Note 1: Stresses beyond those listed under "Absolute Maximum Ratings" may cause permanent damage to the device. These are stress ratings only, and functional operation of the device at these or any other conditions beyond those indicated under "Recommended Operating Conditions" is not implied. Exposure to absolute-maximum-rated conditions for extended periods may affect device reliability.

Note 2: The input and output negative-voltage ratings may be exceeded if the input and output current ratings are observed.

Note 3: The output positive-voltage rating may be exceeded up to 4.6 V maximum if the output current rating is observed.

7.2 Recommended Operating Conditions (Note 1, 2, 3)

Over recommended operating free-air temperature range (unless otherwise noted).

Symbol	Parameter		V _{CCI}	V _{CCO}	Min	Max	Unit
V _{CCA}	Supply voltage				1	3.6	V
V _{CCB}					1	3.6	
V _{IH}	High-level input voltage	Data inputs	1V		V _{CCI} ×0.7		V
			1.1 V to 1.95 V		V _{CCI} ×0.65		
			1.95 V to 2.7 V		1.6		
			2.7V to 3.6 V		2		
V _{IL}	Low-level input voltage	Data inputs	1V			V _{CCI} ×0.3	V
			1.1 V to 1.95 V			V _{CCI} ×0.35	
			1.95 V to 2.7 V			0.7	
			2.7V to 3.6 V			0.8	
V _{IH}	High-level input voltage	Control inputs (DIR, \overline{OE}) referenced to V _{CCA}	1V		V _{CCI} ×0.7		V
			1.1 V to 1.95 V		V _{CCI} ×0.65		
			1.95 V to 2.7 V		1.6		
			2.7V to 3.6 V		2		
V _{IL}	Low-level input voltage	Control inputs (DIR, \overline{OE}) referenced to V _{CCA}	1V			V _{CCI} ×0.3	V
			1.1 V to 1.95 V			V _{CCI} ×0.35	
			1.95 V to 2.7 V			0.7	
			2.7V to 3.6 V			0.8	
V _I	Input voltage			0	3.6	V	
V _O	Output voltage	Active state			0	V _{CCO}	V
		Three-State			0	3.6	
I _{OH}	High-level output current		1.1V to 1.3 V			-3	mA
			1.4 V to 1.6 V			-6	
			1.65 V to 1.95 V			-8	
			2.3 V to 2.7 V			-9	
			3 V to 3.6 V			-12	
I _{OL}	Low-level output current		1.1V to 1.3 V			3	mA
			1.4 V to 1.6 V			6	
			1.65 V to 1.95 V			8	
			2.3 V to 2.7 V			9	
			3 V to 3.6 V			12	
Δt/ΔV	Input transition rise or fall rate				10	ns/V	
T _A	Operating free-air temperature			-40	125	°C	

Note 1: V_{CCI} is the V_{CC} associated with the input port.

Note 2: V_{CCO} is the V_{CC} associated with the output port.

Note 3: All unused or driven (floating) data inputs (I/Os) of the device must be held at logic High or Low (preferably V_{CCI} or GND) to ensure proper device operation and minimize power.

7.3 Package Thermal Impedance

Symbol	Parameter		Value	Unit
R _{θJA}	Junction-to-ambient thermal resistance	TSSOP24	100.6	°C/W
		QFN24 3.5×5.5	48.3	
R _{θJC(TOP)}	Junction-to-case (top) thermal resistance	TSSOP24	44.7	°C/W
		QFN24 3.5×5.5	46.1	
R _{θJB}	Junction-to-board thermal resistance	TSSOP24	55.8	°C/W
		QFN24 3.5×5.5	26.1	

7.4 Electrical Characteristics (Note 1, 2)

Over recommended operating free-air temperature range (unless otherwise noted).

Parameter	Test Conditions	V _{CCA}	V _{CCB}	Min	Typ	Max	Unit	
V _{OH}	I _{OH} =-100μA I _{OH} =-3mA I _{OH} =-6mA I _{OH} =-8mA I _{OH} =-9mA I _{OH} =-12mA	V _I =V _{IH}	1V to 3.6V	1V to 3.6V	V _{CCO} -0.2			V
			1.1V	1.1V	0.85	0.98		
			1.4V	1.4V	1			
			1.65V	1.65V	1.2			
			2.3V	2.3V	1.8			
			3V	3V	2.4			
V _{OL}	I _{OL} =100μA I _{OL} =3mA I _{OL} =6mA I _{OL} =8mA I _{OL} =9mA I _{OL} =12mA	V _I =V _{IL}	1V to 3.6V	1V to 3.6V			0.2	V
			1.1V	1.1V		0.1	0.25	
			1.4V	1.4V			0.35	
			1.65V	1.65V			0.45	
			2.3V	2.3V			0.55	
			3V	3V			0.7	
I _I Control inputs	V _I = V _{CCA} or GND	1V to 3.6V	1V to 3.6V	-1	0.1	1	μA	
I _{OZ} A or B Port	V _O = V _{CCO} or GND, V _I = V _{CCI} or GND, OE = V _{IH}	3.6V	3.6V	-5	0.1	5	μA	
I _{OFF} A or B Port	V _I or V _O = 0 to 3.6V	0V	0V to 3.6V	-5	0.1	5	μA	
		0V to 3.6V	0V	-5	0.1	5		
I _{CCA}	V _I =V _{CCI} or GND I _O =0	1V to 3.6V	1V to 3.6V			8	μA	
		0V	3.6V	-2				
		3.6V	0V			8		
I _{CCB}	V _I =V _{CCB} or GND I _O =0	1V to 3.6V	1V to 3.6V			8	μA	
		0V	3.6V			8		
		3.6V	0V	-2				
I _{CCA} +I _{CCB}	V _I =V _{CCI} or GND I _O =0	1V to 3.6V	1V to 3.6V			16	μA	
C _I Control inputs	V _I = 3.3V or GND	3.3V	3.3V			7.5	pF	
C _{IO} A or B Port	V _O = 3.3V or GND	3.3V	3.3V			8.5	pF	

Note 1: V_{CCI} is the V_{CC} associated with the input port.

Note 2: V_{CCO} is the V_{CC} associated with the output port.

7.5 Switching Characteristics

Over recommended operating free-air temperature range, $V_{CCA} = 1V$.

Parameter	From (Input)	To (Output)	V_{CCB}	Min	Typ	Max	Unit
t_{PLH}, t_{PHL}	A	B	$V_{CCB}=1V$	0.5		30	ns
			$V_{CCB}=1.2V \pm 0.1V$	0.5		20	
			$V_{CCB}=1.5V \pm 0.1V$	0.5		17	
			$V_{CCB}=1.8V \pm 0.15V$	0.5		15	
			$V_{CCB}=2.5V \pm 0.2V$	0.5		15	
			$V_{CCB}=3.3V \pm 0.3V$	0.5		17	
t_{PLH}, t_{PHL}	B	A	$V_{CCB}=1V$	0.5		30	ns
			$V_{CCB}=1.2V \pm 0.1V$	0.5		20	
			$V_{CCB}=1.5V \pm 0.1V$	0.5		17	
			$V_{CCB}=1.8V \pm 0.15V$	0.5		15	
			$V_{CCB}=2.5V \pm 0.2V$	0.5		17	
			$V_{CCB}=3.3V \pm 0.3V$	0.5		17	
t_{PZH}, t_{PZL}	\overline{OE}	A	$V_{CCB}=1V$	0.5		35	ns
			$V_{CCB}=1.2V \pm 0.1V$	0.5		35	
			$V_{CCB}=1.5V \pm 0.1V$	0.5		35	
			$V_{CCB}=1.8V \pm 0.15V$	0.5		35	
			$V_{CCB}=2.5V \pm 0.2V$	0.5		35	
			$V_{CCB}=3.3V \pm 0.3V$	0.5		35	
t_{PZH}, t_{PZL}	\overline{OE}	B	$V_{CCB}=1V$	0.5		40	ns
			$V_{CCB}=1.2V \pm 0.1V$	0.5		35	
			$V_{CCB}=1.5V \pm 0.1V$	0.5		35	
			$V_{CCB}=1.8V \pm 0.15V$	0.5		35	
			$V_{CCB}=2.5V \pm 0.2V$	0.5		35	
			$V_{CCB}=3.3V \pm 0.3V$	0.5		35	
t_{PHZ}, t_{PLZ}	\overline{OE}	A	$V_{CCB}=1V$	0.5		35	ns
			$V_{CCB}=1.2V \pm 0.1V$	0.5		35	
			$V_{CCB}=1.5V \pm 0.1V$	0.5		35	
			$V_{CCB}=1.8V \pm 0.15V$	0.5		35	
			$V_{CCB}=2.5V \pm 0.2V$	0.5		35	
			$V_{CCB}=3.3V \pm 0.3V$	0.5		35	
t_{PHZ}, t_{PLZ}	\overline{OE}	B	$V_{CCB}=1V$	0.5		40	ns
			$V_{CCB}=1.2V \pm 0.1V$	0.5		35	
			$V_{CCB}=1.5V \pm 0.1V$	0.5		35	
			$V_{CCB}=1.8V \pm 0.15V$	0.5		35	
			$V_{CCB}=2.5V \pm 0.2V$	0.5		35	
			$V_{CCB}=3.3V \pm 0.3V$	0.5		35	

7.5 Switching Characteristics (continued)

Over recommended operating free-air temperature range, $V_{CCA} = 1.2V \pm 0.1V$.

Parameter	From (Input)	To (Output)	V_{CCB}	Min	Typ	Max	Unit
t_{PLH}, t_{PHL}	A	B	$V_{CCB}=1V$	0.5		23	ns
			$V_{CCB}=1.2V \pm 0.1V$	0.5		15	
			$V_{CCB}=1.5V \pm 0.1V$	0.5		10	
			$V_{CCB}=1.8V \pm 0.15V$	0.5		9	
			$V_{CCB}=2.5V \pm 0.2V$	0.5		7	
			$V_{CCB}=3.3V \pm 0.3V$	0.5		7.5	
t_{PLH}, t_{PHL}	B	A	$V_{CCB}=1V$	0.5		23	ns
			$V_{CCB}=1.2V \pm 0.1V$	0.5		15	
			$V_{CCB}=1.5V \pm 0.1V$	0.5		13	
			$V_{CCB}=1.8V \pm 0.15V$	0.5		11	
			$V_{CCB}=2.5V \pm 0.2V$	0.5		8	
			$V_{CCB}=3.3V \pm 0.3V$	0.5		7	
t_{PZH}, t_{PZL}	\overline{OE}	A	$V_{CCB}=1V$	0.5		30	ns
			$V_{CCB}=1.2V \pm 0.1V$	0.5		30	
			$V_{CCB}=1.5V \pm 0.1V$	0.5		30	
			$V_{CCB}=1.8V \pm 0.15V$	0.5		30	
			$V_{CCB}=2.5V \pm 0.2V$	0.5		30	
			$V_{CCB}=3.3V \pm 0.3V$	0.5		30	
t_{PZH}, t_{PZL}	\overline{OE}	B	$V_{CCB}=1V$	0.5		30	ns
			$V_{CCB}=1.2V \pm 0.1V$	0.5		25	
			$V_{CCB}=1.5V \pm 0.1V$	0.5		22	
			$V_{CCB}=1.8V \pm 0.15V$	0.5		19	
			$V_{CCB}=2.5V \pm 0.2V$	0.5		17	
			$V_{CCB}=3.3V \pm 0.3V$	0.5		17	
t_{PHZ}, t_{PLZ}	\overline{OE}	A	$V_{CCB}=1V$	0.5		35	ns
			$V_{CCB}=1.2V \pm 0.1V$	0.5		30	
			$V_{CCB}=1.5V \pm 0.1V$	0.5		30	
			$V_{CCB}=1.8V \pm 0.15V$	0.5		30	
			$V_{CCB}=2.5V \pm 0.2V$	0.5		30	
			$V_{CCB}=3.3V \pm 0.3V$	0.5		30	
t_{PHZ}, t_{PLZ}	\overline{OE}	B	$V_{CCB}=1V$	0.5		35	ns
			$V_{CCB}=1.2V \pm 0.1V$	0.5		30	
			$V_{CCB}=1.5V \pm 0.1V$	0.5		30	
			$V_{CCB}=1.8V \pm 0.15V$	0.5		30	
			$V_{CCB}=2.5V \pm 0.2V$	0.5		30	
			$V_{CCB}=3.3V \pm 0.3V$	0.5		30	

7.5 Switching Characteristics (continued)

 Over recommended operating free-air temperature range, $V_{CCA} = 1.5V \pm 0.1V$.

Parameter	From (Input)	To (Output)	V_{CCB}	Min	Typ	Max	Unit
t_{PLH}, t_{PHL}	A	B	$V_{CCB}=1V$	0.5		18	ns
			$V_{CCB}=1.2V \pm 0.1V$	0.5		13	
			$V_{CCB}=1.5V \pm 0.1V$	0.5		9	
			$V_{CCB}=1.8V \pm 0.15V$	0.5		7	
			$V_{CCB}=2.5V \pm 0.2V$	0.5		6	
			$V_{CCB}=3.3V \pm 0.3V$	0.5		5.5	
t_{PLH}, t_{PHL}	B	A	$V_{CCB}=1V$	0.5		17	ns
			$V_{CCB}=1.2V \pm 0.1V$	0.5		11	
			$V_{CCB}=1.5V \pm 0.1V$	0.5		9	
			$V_{CCB}=1.8V \pm 0.15V$	0.5		7.5	
			$V_{CCB}=2.5V \pm 0.2V$	0.5		6	
			$V_{CCB}=3.3V \pm 0.3V$	0.5		5	
t_{PZH}, t_{PZL}	\overline{OE}	A	$V_{CCB}=1V$	0.5		23	ns
			$V_{CCB}=1.2V \pm 0.1V$	0.5		23	
			$V_{CCB}=1.5V \pm 0.1V$	0.5		23	
			$V_{CCB}=1.8V \pm 0.15V$	0.5		23	
			$V_{CCB}=2.5V \pm 0.2V$	0.5		23	
			$V_{CCB}=3.3V \pm 0.3V$	0.5		23	
t_{PZH}, t_{PZL}	\overline{OE}	B	$V_{CCB}=1V$	0.5		27	ns
			$V_{CCB}=1.2V \pm 0.1V$	0.5		24	
			$V_{CCB}=1.5V \pm 0.1V$	0.5		17	
			$V_{CCB}=1.8V \pm 0.15V$	0.5		15	
			$V_{CCB}=2.5V \pm 0.2V$	0.5		12	
			$V_{CCB}=3.3V \pm 0.3V$	0.5		11	
t_{PHZ}, t_{PLZ}	\overline{OE}	A	$V_{CCB}=1V$	0.5		34	ns
			$V_{CCB}=1.2V \pm 0.1V$	0.5		34	
			$V_{CCB}=1.5V \pm 0.1V$	0.5		34	
			$V_{CCB}=1.8V \pm 0.15V$	0.5		34	
			$V_{CCB}=2.5V \pm 0.2V$	0.5		34	
			$V_{CCB}=3.3V \pm 0.3V$	0.5		34	
t_{PHZ}, t_{PLZ}	\overline{OE}	B	$V_{CCB}=1V$	0.5		45	ns
			$V_{CCB}=1.2V \pm 0.1V$	0.5		40	
			$V_{CCB}=1.5V \pm 0.1V$	0.5		35	
			$V_{CCB}=1.8V \pm 0.15V$	0.5		31	
			$V_{CCB}=2.5V \pm 0.2V$	0.5		28	
			$V_{CCB}=3.3V \pm 0.3V$	0.5		25	

7.5 Switching Characteristics (continued)

Over recommended operating free-air temperature range, $V_{CCA} = 1.8V \pm 0.15V$.

Parameter	From (Input)	To (Output)	V_{CCB}	Min	Typ	Max	Unit
t_{PLH}, t_{PHL}	A	B	$V_{CCB}=1V$	0.5		16	ns
			$V_{CCB}=1.2V \pm 0.1V$	0.5		11	
			$V_{CCB}=1.5V \pm 0.1V$	0.5		8	
			$V_{CCB}=1.8V \pm 0.15V$	0.5		7	
			$V_{CCB}=2.5V \pm 0.2V$	0.5		6	
			$V_{CCB}=3.3V \pm 0.3V$	0.5		5	
t_{PLH}, t_{PHL}	B	A	$V_{CCB}=1V$	0.5		16	ns
			$V_{CCB}=1.2V \pm 0.1V$	0.5		10	
			$V_{CCB}=1.5V \pm 0.1V$	0.5		7	
			$V_{CCB}=1.8V \pm 0.15V$	0.5		7	
			$V_{CCB}=2.5V \pm 0.2V$	0.5		5	
			$V_{CCB}=3.3V \pm 0.3V$	0.5		4	
t_{pZH}, t_{pZL}	\overline{OE}	A	$V_{CCB}=1V$	0.5		17	ns
			$V_{CCB}=1.2V \pm 0.1V$	0.5		17	
			$V_{CCB}=1.5V \pm 0.1V$	0.5		17	
			$V_{CCB}=1.8V \pm 0.15V$	0.5		17	
			$V_{CCB}=2.5V \pm 0.2V$	0.5		17	
			$V_{CCB}=3.3V \pm 0.3V$	0.5		17	
t_{pZH}, t_{pZL}	\overline{OE}	B	$V_{CCB}=1V$	0.5		23	ns
			$V_{CCB}=1.2V \pm 0.1V$	0.5		23	
			$V_{CCB}=1.5V \pm 0.1V$	0.5		15	
			$V_{CCB}=1.8V \pm 0.15V$	0.5		13	
			$V_{CCB}=2.5V \pm 0.2V$	0.5		10	
			$V_{CCB}=3.3V \pm 0.3V$	0.5		9	
t_{pHZ}, t_{pLZ}	\overline{OE}	A	$V_{CCB}=1V$	0.5		30	ns
			$V_{CCB}=1.2V \pm 0.1V$	0.5		30	
			$V_{CCB}=1.5V \pm 0.1V$	0.5		30	
			$V_{CCB}=1.8V \pm 0.15V$	0.5		30	
			$V_{CCB}=2.5V \pm 0.2V$	0.5		30	
			$V_{CCB}=3.3V \pm 0.3V$	0.5		30	
t_{pHZ}, t_{pLZ}	\overline{OE}	B	$V_{CCB}=1V$	0.5		30	ns
			$V_{CCB}=1.2V \pm 0.1V$	0.5		30	
			$V_{CCB}=1.5V \pm 0.1V$	0.5		30	
			$V_{CCB}=1.8V \pm 0.15V$	0.5		30	
			$V_{CCB}=2.5V \pm 0.2V$	0.5		30	
			$V_{CCB}=3.3V \pm 0.3V$	0.5		30	

7.5 Switching Characteristics (continued)

 Over recommended operating free-air temperature range, $V_{CCA} = 2.5V \pm 0.2V$.

Parameter	From (Input)	To (Output)	V_{CCB}	Min	Typ	Max	Unit
t_{PLH}, t_{PHL}	A	B	$V_{CCB}=1V$	0.5		15	ns
			$V_{CCB}=1.2V \pm 0.1V$	0.5		8	
			$V_{CCB}=1.5V \pm 0.1V$	0.5		6	
			$V_{CCB}=1.8V \pm 0.15V$	0.5		5.5	
			$V_{CCB}=2.5V \pm 0.2V$	0.5		5	
			$V_{CCB}=3.3V \pm 0.3V$	0.5		4	
t_{PLH}, t_{PHL}	B	A	$V_{CCB}=1V$	0.5		15	ns
			$V_{CCB}=1.2V \pm 0.1V$	0.5		7.5	
			$V_{CCB}=1.5V \pm 0.1V$	0.5		6	
			$V_{CCB}=1.8V \pm 0.15V$	0.5		5.5	
			$V_{CCB}=2.5V \pm 0.2V$	0.5		5	
			$V_{CCB}=3.3V \pm 0.3V$	0.5		4	
t_{PZH}, t_{PZL}	\overline{OE}	A	$V_{CCB}=1V$	0.5		16	ns
			$V_{CCB}=1.2V \pm 0.1V$	0.5		12	
			$V_{CCB}=1.5V \pm 0.1V$	0.5		12	
			$V_{CCB}=1.8V \pm 0.15V$	0.5		12	
			$V_{CCB}=2.5V \pm 0.2V$	0.5		12	
			$V_{CCB}=3.3V \pm 0.3V$	0.5		12	
t_{PZH}, t_{PZL}	\overline{OE}	B	$V_{CCB}=1V$	0.5		21	ns
			$V_{CCB}=1.2V \pm 0.1V$	0.5		18	
			$V_{CCB}=1.5V \pm 0.1V$	0.5		14	
			$V_{CCB}=1.8V \pm 0.15V$	0.5		12	
			$V_{CCB}=2.5V \pm 0.2V$	0.5		9	
			$V_{CCB}=3.3V \pm 0.3V$	0.5		8	
t_{PHZ}, t_{PLZ}	\overline{OE}	A	$V_{CCB}=1V$	0.5		25	ns
			$V_{CCB}=1.2V \pm 0.1V$	0.5		25	
			$V_{CCB}=1.5V \pm 0.1V$	0.5		25	
			$V_{CCB}=1.8V \pm 0.15V$	0.5		25	
			$V_{CCB}=2.5V \pm 0.2V$	0.5		25	
			$V_{CCB}=3.3V \pm 0.3V$	0.5		25	
t_{PHZ}, t_{PLZ}	\overline{OE}	B	$V_{CCB}=1V$	0.5		35	ns
			$V_{CCB}=1.2V \pm 0.1V$	0.5		32	
			$V_{CCB}=1.5V \pm 0.1V$	0.5		30	
			$V_{CCB}=1.8V \pm 0.15V$	0.5		28	
			$V_{CCB}=2.5V \pm 0.2V$	0.5		25	
			$V_{CCB}=3.3V \pm 0.3V$	0.5		23	

7.5 Switching Characteristics (continued)

 Over recommended operating free-air temperature range, $V_{CCA} = 3.3V \pm 0.3V$.

Parameter	From (Input)	To (Output)	V_{CCB}	Min	Typ	Max	Unit
t_{PLH}, t_{PHL}	A	B	$V_{CCB}=1V$	0.5		16	ns
			$V_{CCB}=1.2V \pm 0.1V$	0.5		7	
			$V_{CCB}=1.5V \pm 0.1V$	0.5		5	
			$V_{CCB}=1.8V \pm 0.15V$	0.5		4	
			$V_{CCB}=2.5V \pm 0.2V$	0.5		4	
			$V_{CCB}=3.3V \pm 0.3V$	0.5		4	
t_{PLH}, t_{PHL}	B	A	$V_{CCB}=1V$	0.5		16	ns
			$V_{CCB}=1.2V \pm 0.1V$	0.5		7	
			$V_{CCB}=1.5V \pm 0.1V$	0.5		6	
			$V_{CCB}=1.8V \pm 0.15V$	0.5		5	
			$V_{CCB}=2.5V \pm 0.2V$	0.5		4	
			$V_{CCB}=3.3V \pm 0.3V$	0.5		4	
t_{PZH}, t_{PZL}	\overline{OE}	A	$V_{CCB}=1V$	0.5		15.5	ns
			$V_{CCB}=1.2V \pm 0.1V$	0.5		11.5	
			$V_{CCB}=1.5V \pm 0.1V$	0.5		10	
			$V_{CCB}=1.8V \pm 0.15V$	0.5		10	
			$V_{CCB}=2.5V \pm 0.2V$	0.5		10	
			$V_{CCB}=3.3V \pm 0.3V$	0.5		10	
t_{PZH}, t_{PZL}	\overline{OE}	B	$V_{CCB}=1V$	0.5		50	ns
			$V_{CCB}=1.2V \pm 0.1V$	0.5		20	
			$V_{CCB}=1.5V \pm 0.1V$	0.5		14	
			$V_{CCB}=1.8V \pm 0.15V$	0.5		11	
			$V_{CCB}=2.5V \pm 0.2V$	0.5		8	
			$V_{CCB}=3.3V \pm 0.3V$	0.5		7	
t_{PHZ}, t_{PLZ}	\overline{OE}	A	$V_{CCB}=1V$	0.5		22	ns
			$V_{CCB}=1.2V \pm 0.1V$	0.5		22	
			$V_{CCB}=1.5V \pm 0.1V$	0.5		22	
			$V_{CCB}=1.8V \pm 0.15V$	0.5		22	
			$V_{CCB}=2.5V \pm 0.2V$	0.5		22	
			$V_{CCB}=3.3V \pm 0.3V$	0.5		22	
t_{PHZ}, t_{PLZ}	\overline{OE}	B	$V_{CCB}=1V$	0.5		36	ns
			$V_{CCB}=1.2V \pm 0.1V$	0.5		33	
			$V_{CCB}=1.5V \pm 0.1V$	0.5		30	
			$V_{CCB}=1.8V \pm 0.15V$	0.5		27	
			$V_{CCB}=2.5V \pm 0.2V$	0.5		25	
			$V_{CCB}=3.3V \pm 0.3V$	0.5		23	

7.6 Operating Characteristics (Note 1)

$T_A=25^{\circ}\text{C}$.

Parameter			Test Conditions	$V_{CCA} =$ $V_{CCB} =$ 1V	$V_{CCA} =$ $V_{CCB} =$ 1.2V	$V_{CCA} =$ $V_{CCB} =$ 1.5V	$V_{CCA} =$ $V_{CCB} =$ 1.8V	$V_{CCA} =$ $V_{CCB} =$ 2.5V	$V_{CCA} =$ $V_{CCB} =$ 3.3V	Unit
				Typ	Typ	Typ	Typ	Typ	Typ	
C_{PDA}	A to B	Outputs enabled	$C_L = 0,$ $f=10\text{MHz},$ $t_R = t_F = 1\text{ns}$	2	2.2	2.3	2.5	2.7	3.5	pF
		Outputs disabled		1	1	1	1	1	1	
	B to A	Outputs enabled		12	12	12	12	13	13.5	
		Outputs disabled		1	1	1	1	1	1	
C_{PDB}	A to B	Outputs enabled		12	12	12	12	13	13.5	
		Outputs disabled		1	1	1	1	1	1	
	B to A	Outputs enabled		2	2.2	2.3	2.5	2.7	3.5	
		Outputs disabled		1	1	1	1	1	1	

Note 1: C_{PDA} and C_{PDB} are power dissipation capacitance per transceiver.

8 Parameter Measurement Information

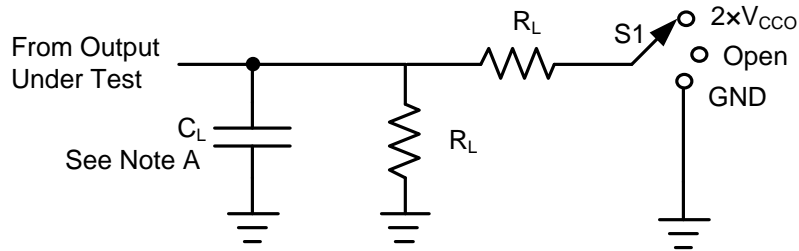

Figure 8-1. Load Circuit

Parameter	V _{CCO}	C _L	R _L	S1	V _{TP}
t _{PD}	1V to 3.6V	15pF	2kΩ	Open	N/A
t _{PLZ} , t _{PZL}	1V to 1.6V	15pF	2kΩ	2 × V _{CCO}	0.1V
	1.65V to 2.7V	15pF	2kΩ	2 × V _{CCO}	0.15V
	3V to 3.6V	15pF	2kΩ	2 × V _{CCO}	0.3V
t _{PHZ} , t _{PZH}	1V to 1.6V	15pF	2kΩ	GND	0.1V
	1.65V to 2.7V	15pF	2kΩ	GND	0.15V
	3V to 3.6V	15pF	2kΩ	GND	0.3V

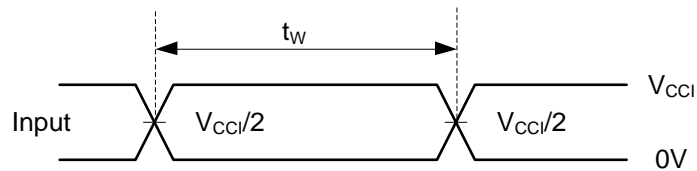

Figure 8-2. Voltage Waveforms Pulse Duration

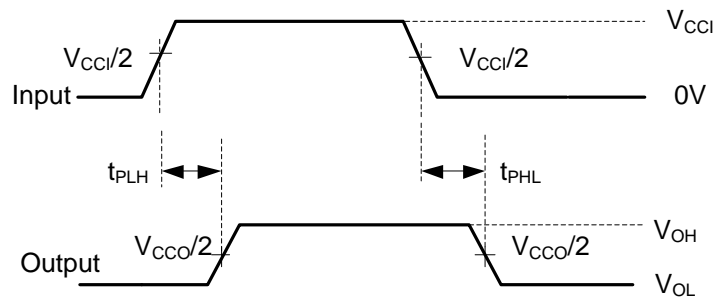

Figure 8-3. Voltage Waveforms Propagation Delay Times

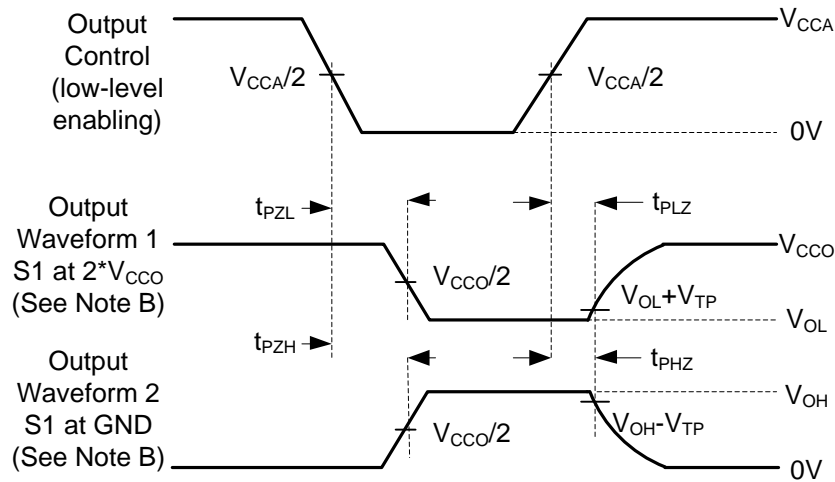

Figure 8-4. Voltage Waveforms Enable and Disable Times

Notes:

- A. C_L includes probe and jig capacitance.
- B. Waveform 1 is for an output with internal conditions such that the output is low, except when disabled by the output control. Waveform 2 is for an output with internal conditions such that the output is high, except when disabled by the output control.
- C. All input pulses are supplied by generators having the following characteristics: $PRR \leq 10$ MHz, $Z_0 = 50\Omega$, $dv/dt \geq 1V/ns$.
- D. The outputs are measured one at a time, with one transition per measurement.
- E. t_{PLZ} and t_{PHZ} are the same as t_{DIS} .
- F. t_{PZL} and t_{PZH} are the same as t_{EN} .
- G. t_{PLH} and t_{PHL} are the same as t_{PD} .
- H. V_{CCI} is the V_{CC} associated with the input port.
- I. V_{CCO} is the V_{CC} associated with the output port.

9 Detailed Description

9.1 Overview

The UM74AVC8T245 device is an 8-bit, dual-supply non-inverting transceiver with bidirectional voltage level translation. The I/O pins labeled with A and the control pins (DIR and \overline{OE}) are supported by V_{CCA} , and the I/O pins labeled with B are supported by V_{CCB} . The A port and the B port are able to accept I/O voltages ranging from 1 V to 3.6 V.

9.2 Functional Block Diagram

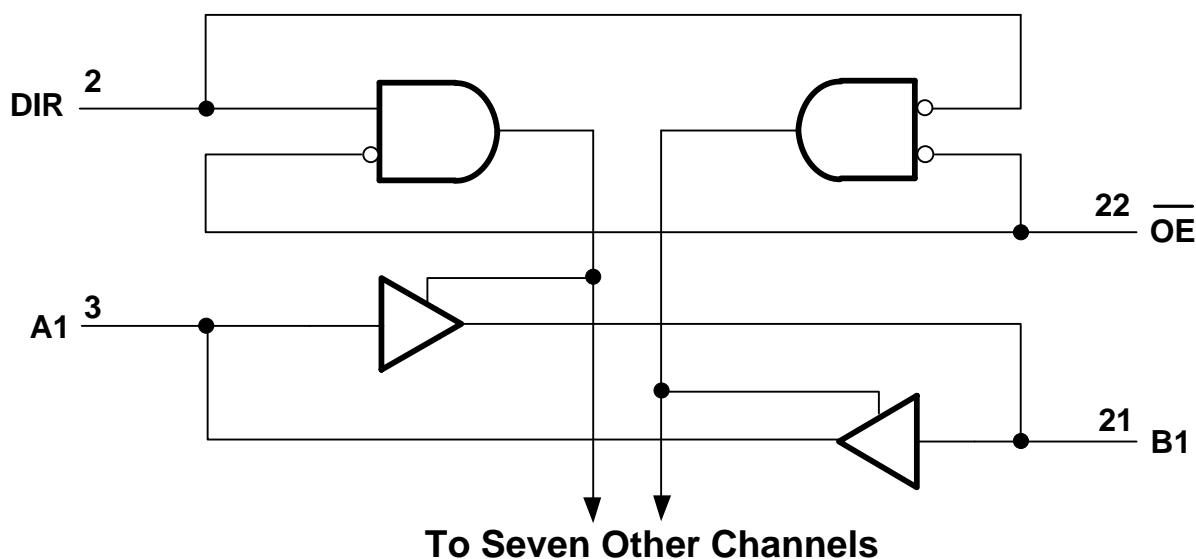

Figure 9-1. UM74AVC8T245 Block Diagram

10 Feature Description

10.1 Fully Configurable Dual-Rail Design

The fully configurable dual-rail design allows each port to operate over the full 1 V to 3.6 V power-supply range. Both V_{CCA} and V_{CCB} can be supplied at any voltage between 1 V and 3.6 V making the device an excellent choice for translating between any of the low voltage nodes (1 V, 1.2 V, 1.8 V, 2.5 V and 3.3 V).

10.2 I_{OFF} Supports Partial-Power-Down Mode Operation

I_{OFF} prevents backflow current by disabling I/O output circuits when device is in partial power-down mode. The inputs and outputs for this device enter a high-impedance state when the device is powered down, inhibiting current backflow into the device. The maximum leakage into or out of any input or output pin on the device is specified by I_{OFF} in the Electrical Characteristics.

10.3 V_{CC} Isolation

The I/Os of both ports will enter a high-impedance state when one of the supplies are at GND, while the other supply is still connected to the device (I_{OZ} shown in Electrical Characteristics).

10.4 Device Functional Modes

All control inputs are referenced to V_{CCA} and must be driven to a valid Logic High or Logic Low (that is, not floating) to assure proper device operation and to prevent excessive power consumption. Table 10-1 summarizes the possible modes of device operation based on the configuration of the control inputs.

Table 10-1. Function Table

Control Inputs		Output Circuits		Operation
\overline{OE}	DIR	A port	B port	
L	L	Enabled	Hi-Z	B data to A bus
L	H	Hi-Z	Enabled	A data to B bus
H	X	Hi-Z	Hi-Z	Isolation

11 Application Information

11.1 Application Information

The UM74AVC8T245 device can be used in level-translation applications for interfacing devices or systems operating at different voltage nodes. Typical Application Circuit depicts an application in which the UM74AVC8T245 device is up-translating a 1.8V input to a 3.3V output to interface between a system controller and a peripheral device.

11.2 Typical Application

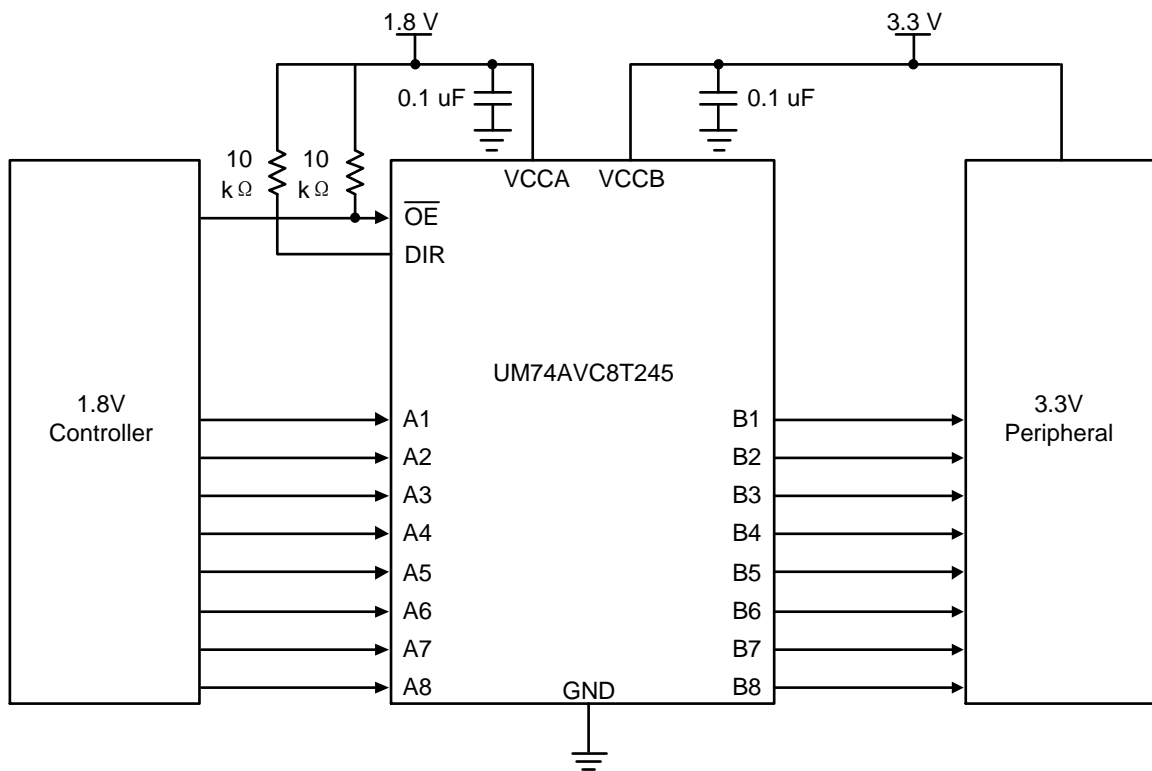
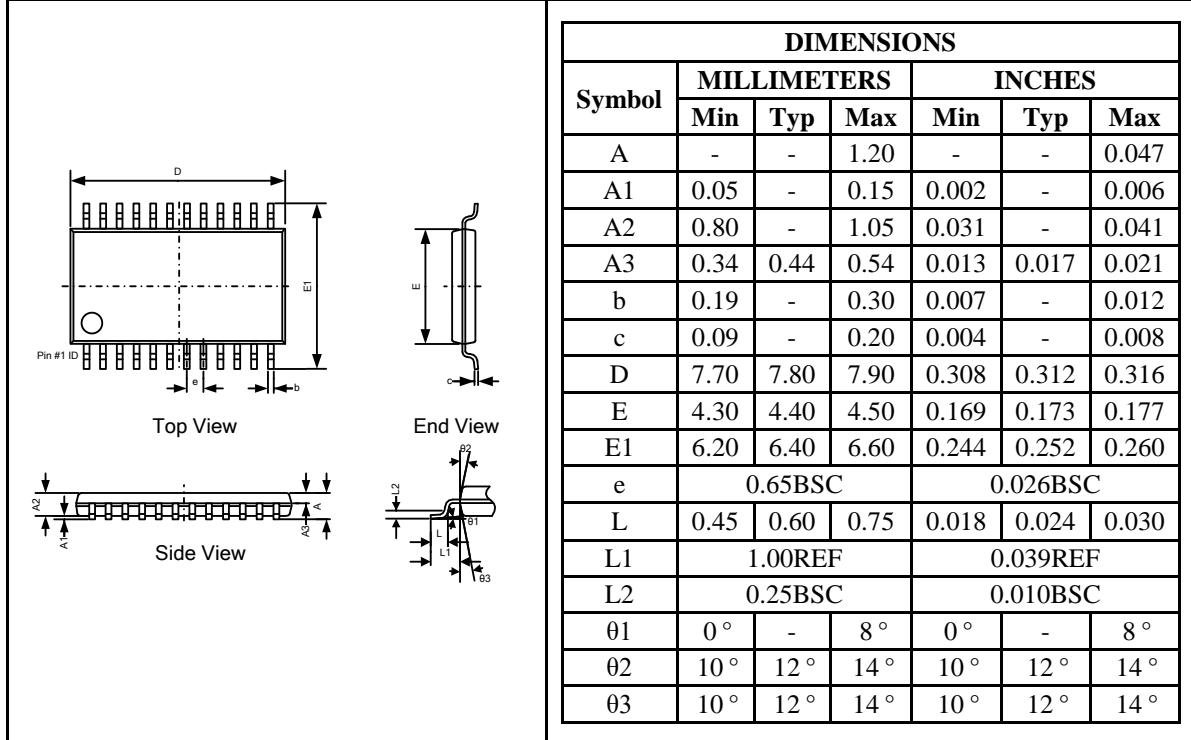

Figure 11-1. UM74AVC8T245 Typical Application

Package Information

TSSOP24

Outline Drawing



Land Pattern

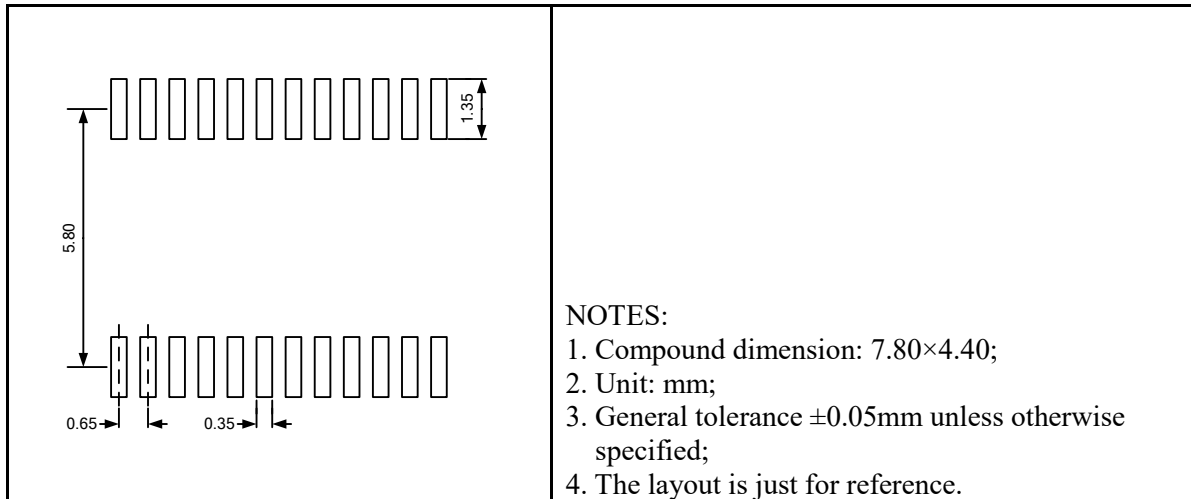

QFN24 3.5×5.5

Outline Drawing

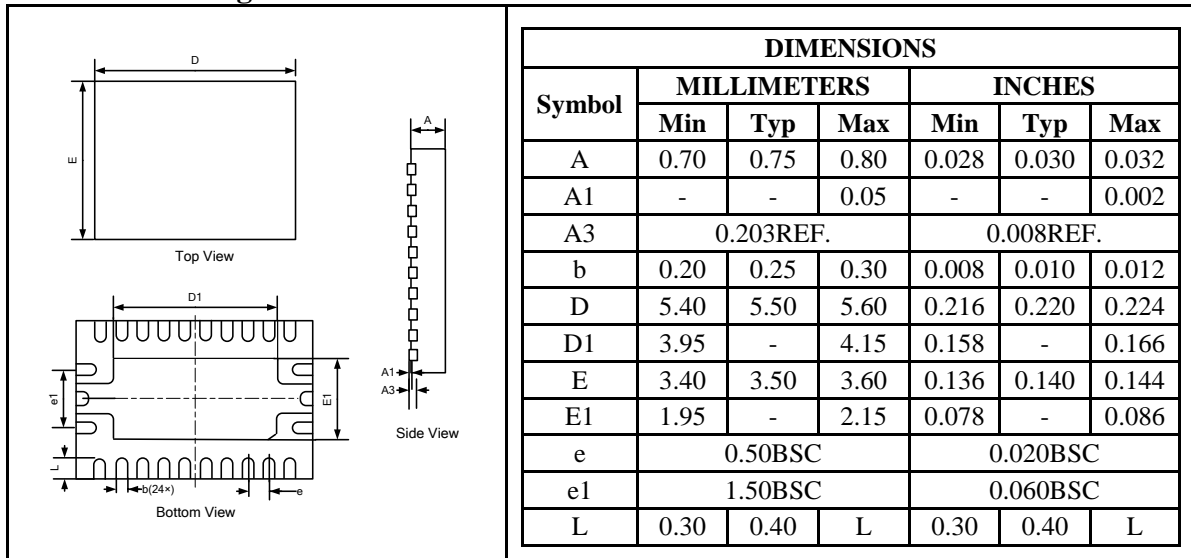

Land Pattern

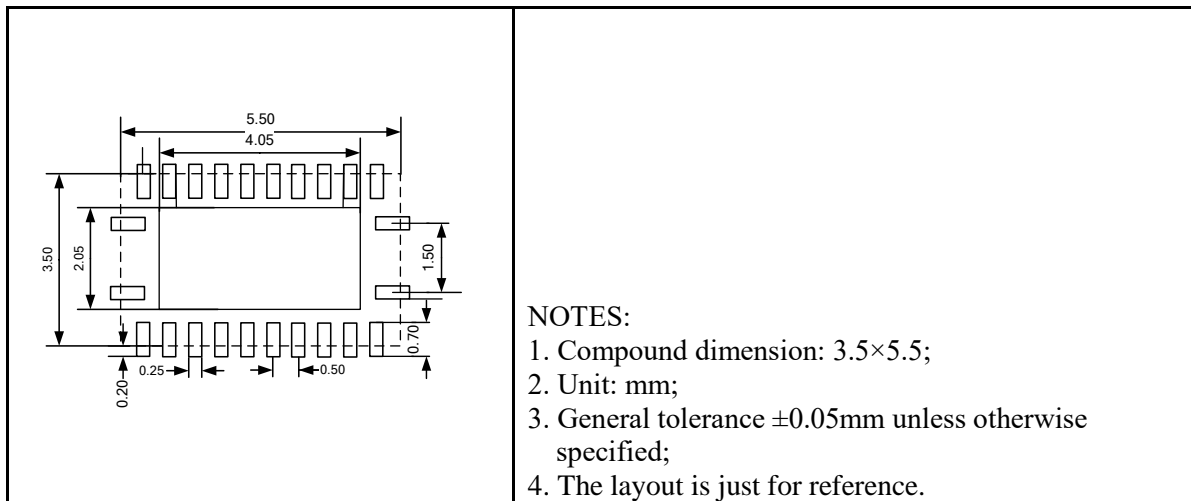

Packing Information

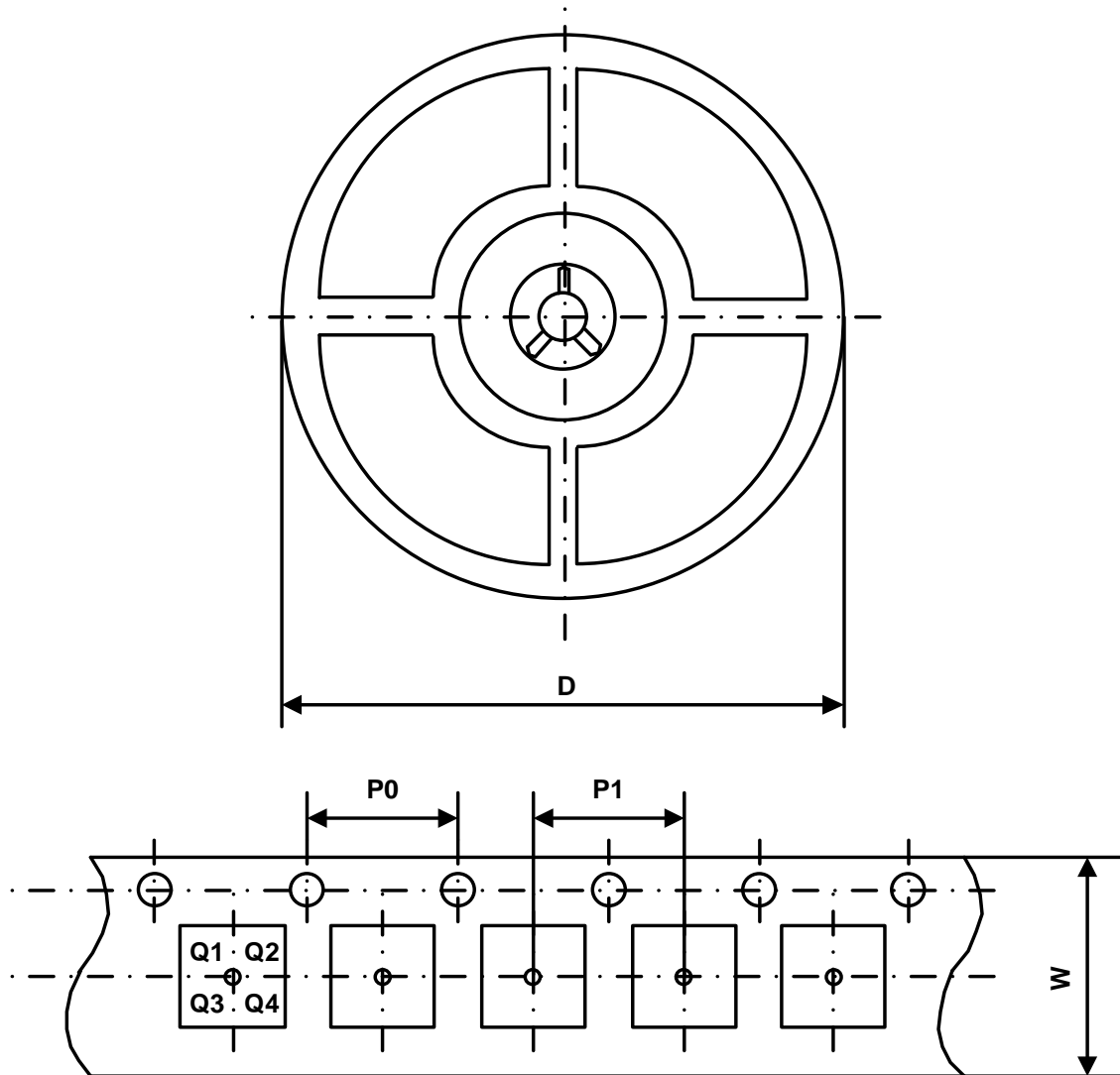

Part Number	Package Type	Carrier Width (W)	Pitch (P0)	Pitch (P1)	Reel Size (D)	PIN 1 Quadrant
UM74AVC8T245UO	TSSOP24	16 mm	4 mm	8 mm	330 mm	Q1
UM74AVC8T245QB	QFN24 3.5×5.5	12 mm	4 mm	8 mm	330 mm	Q1

GREEN COMPLIANCE

Union Semiconductor is committed to environmental excellence in all aspects of its operations including meeting or exceeding regulatory requirements with respect to the use of hazardous substances. Numerous successful programs have been implemented to reduce the use of hazardous substances and/or emissions.

All Union components are compliant with the RoHS directive, which helps to support customers in their compliance with environmental directives. For more green compliance information, please visit:

http://www.union-ic.com/index.aspx?cat_code=RoHSDeclaration

IMPORTANT NOTICE

The information in this document has been carefully reviewed and is believed to be accurate. Nonetheless, this document is subject to change without notice. Union assumes no responsibility for any inaccuracies that may be contained in this document, and makes no commitment to update or to keep current the contained information, or to notify a person or organization of any update. Union reserves the right to make changes, at any time, in order to improve reliability, function or design and to attempt to supply the best product possible.