

***Supply Voltage Supervisor w/Watchdog Input and Manual Reset*****UM706xS SOP8****UM706xM8 MSOP8****UM708xS SOP8****UM813xS SOP8****General Description**

The UM706xS/UM706xM8/UM708xS/UM813xS series are cost effective system power supply supervisory circuits designed to monitor the power supplies in digital systems.

The UM706xS/UM706xM8 provides power-supply monitoring circuitry that generates a reset output during power-up, power-down, and brownout conditions. The reset output remains operational with  $V_{CC}$  as low as 1V. Independent watchdog monitoring circuitry is also provided. This is activated if the watchdog input has not been toggled within 1.6 seconds. In addition, there is a 1.25V threshold detector for power-fail warning, low battery detection, or to monitor an additional power supply. An active low debounced manual reset input is also included.

The UM708xS is the same as the UM706xS, except an active-high reset is substituted for the watchdog timer. The UM813xS is the same as the UM706xS, except RESET is provided instead of  $\overline{\text{RESET}}$ .

The UM706xS, UM708xS, UM813xS are available in a small outline SOP8 package. The UM706xM8 is available in MSOP8 package.

**Applications**

- Applications Using DSPs, Microcontrollers or Microprocessors
- Programmable Controls
- Computers
- Embedded Systems
- Industrial Equipments
- Intelligent Instruments
- Wireless Communications Systems

**Features**

- Wide Operation Voltage Range of 1V to 5.5V
- Correct Logic Output Guaranteed to  $V_{CC}=1.0V$
- Precision Supply-Voltage Monitor: 2.63V, 2.93V, 3.08V, 4.38V, 4.63V
- 200ms Reset Pulse Width
- Independent Watchdog Timer-1.6s Timeout (UM706xS, UM706xM8, UM813xS)
- Active-High Reset Output (UM708xS, UM813xS)
- Voltage Monitor for Power-Fail or Low-Battery Warning
- Temperature Range: -40 °C to +85 °C
- Supply Current of 80 $\mu$ A (Typ)

## Pin Configurations

## Top View

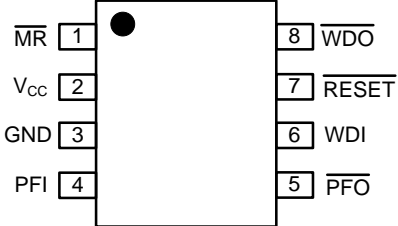
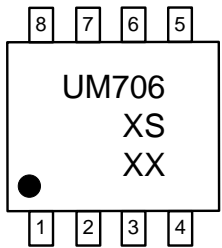
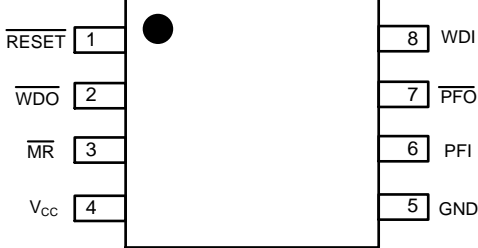
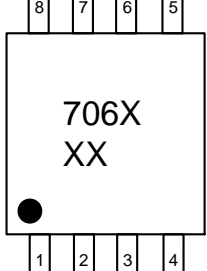
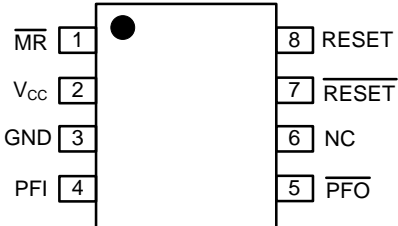
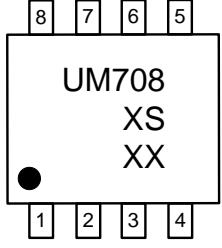
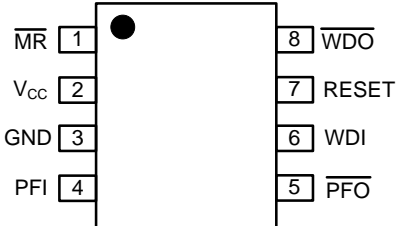
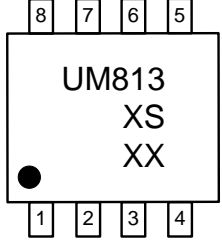
 <p>MR 1</p> <p>V<sub>cc</sub> 2</p> <p>GND 3</p> <p>PFI 4</p> <p>8 WDO</p> <p>7 RESET</p> <p>6 WDI</p> <p>5 PFO</p> <p><b>UM706xS</b></p>	 <p>8 7 6 5</p> <p>UM706 XS XX</p> <p>1 2 3 4</p> <p>XX: Week Code <b>UM706xS SOP8</b></p>
 <p>RESET 1</p> <p>WDO 2</p> <p>MR 3</p> <p>V<sub>cc</sub> 4</p> <p>8 WDI</p> <p>7 PFO</p> <p>6 PFI</p> <p>5 GND</p> <p><b>UM706xM8</b></p>	 <p>8 7 6 5</p> <p>706X XX</p> <p>1 2 3 4</p> <p>XX: Week Code <b>UM706xM8 MSOP8</b></p>
 <p>MR 1</p> <p>V<sub>cc</sub> 2</p> <p>GND 3</p> <p>PFI 4</p> <p>8 RESET</p> <p>7 RESET</p> <p>6 NC</p> <p>5 PFO</p> <p><b>UM708xS</b></p>	 <p>8 7 6 5</p> <p>UM708 XS XX</p> <p>1 2 3 4</p> <p>XX: Week Code <b>UM708xS SOP8</b></p>
 <p>MR 1</p> <p>V<sub>cc</sub> 2</p> <p>GND 3</p> <p>PFI 4</p> <p>8 WDO</p> <p>7 RESET</p> <p>6 WDI</p> <p>5 PFO</p> <p><b>UM813xS</b></p>	 <p>8 7 6 5</p> <p>UM813 XS XX</p> <p>1 2 3 4</p> <p>XX: Week Code <b>UM813xS SOP8</b></p>

**Ordering Information**

Part Number	Top Marking	RESET Threshold (V)	Timeout Period (ms)	Package Type	Shipping Qty
UM706LS	UM706LS	4.63	240	SOP8	3000pcs/13 Inch Tape and Reel
UM706MS	UM706MS	4.38	240		
UM706TS	UM706TS	3.08	240		
UM706SS	UM706SS	2.93	240		
UM706RS	UM706RS	2.63	240		
UM708LS	UM708LS	4.63	240		
UM708MS	UM708MS	4.38	240		
UM708TS	UM708TS	3.08	240		
UM708SS	UM708SS	2.93	240		
UM708RS	UM708RS	2.63	240		
UM813LS	UM813LS	4.63	240		
UM813MS	UM813MS	4.38	240		
UM813TS	UM813TS	3.08	240		
UM813SS	UM813SS	2.93	240		
UM813RS	UM813RS	2.63	240		
UM706LM8	706L	4.63	240	MSOP8	4000pcs/13Inch Tape & Reel
UM706MM8	706M	4.38	240		
UM706TM8	706T	3.08	240		
UM706SM8	706S	2.93	240		
UM706RM8	706R	2.63	240		

Typical Application Circuits

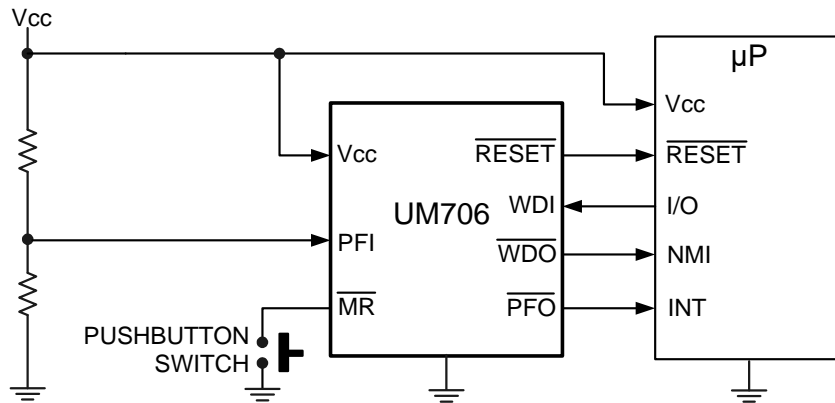

Figure 1. UM706xS/UM706xM8 Application Circuit

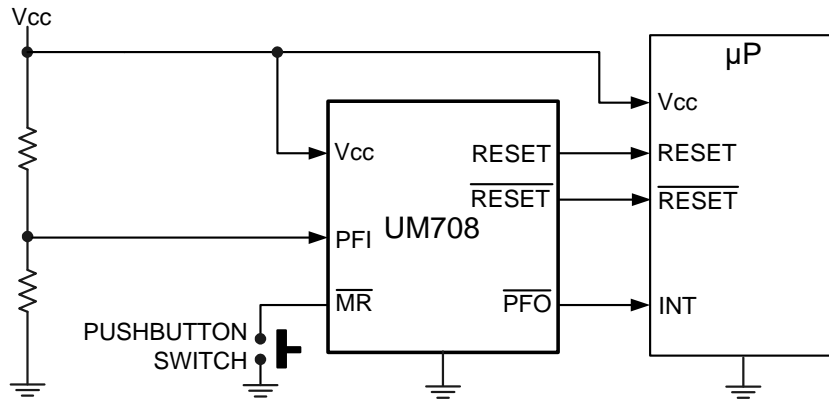

Figure 2. UM708xS Application Circuit

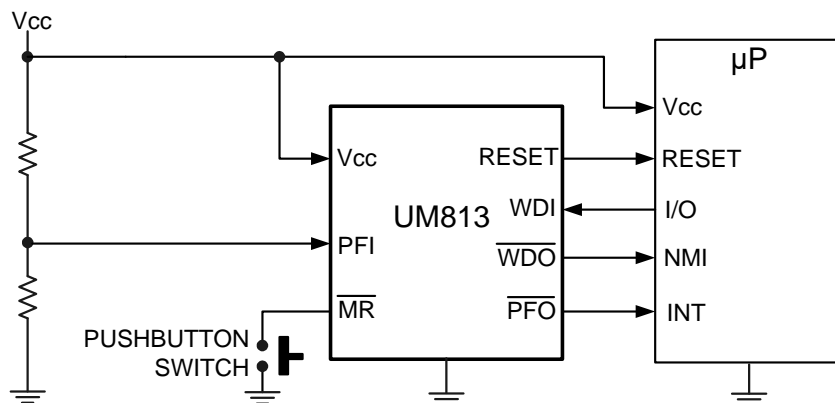

Figure 3. UM813xS Application Circuit

**Pin Description**

Pin Name	Function
$\overline{\text{MR}}$	Manual-Reset Input triggers a reset pulse when pulled below 0.8V. This active-low input has an internal 250 $\mu$ A pull-up current. It can be driven from a TTL or CMOS logic line as well as shorted to ground with a switch.
$V_{\text{CC}}$	Supply Input.
GND	Ground Reference for all signals.
PFI	Power-Fail Voltage Monitor Input. When PFI is less than 1.25V, $\overline{\text{PFO}}$ goes low. Connect PFI to GND or $V_{\text{CC}}$ when not used.
$\overline{\text{PFO}}$	Power-Fail Output goes low and sinks current when PFI is less than 1.25V; otherwise $\overline{\text{PFO}}$ stays high.
WDI	Watchdog Input. If WDI remains either high or low for 1.6sec, the internal watchdog timer runs out and the $\overline{\text{WDO}}$ goes low. Floating WDI or connecting WDI to a high-impedance three-state buffer disables the watchdog feature. The internal watchdog timer clears whenever reset is asserted, WDI is three-stated, or WDI sees a rising or falling edge.
NC	Not Connected.
$\overline{\text{RESET}}$	Active-Low Reset Output pulses low for 200ms when triggered, and stays low whenever $V_{\text{CC}}$ is below the reset threshold. It remains low for 200ms after $V_{\text{CC}}$ rises above the reset threshold or $\overline{\text{MR}}$ goes from Low to High.
RESET	Active-High Reset Output is the inverse of $\overline{\text{RESET}}$ . Whenever RESET is high, $\overline{\text{RESET}}$ is low, and vice versa.
$\overline{\text{WDO}}$	Watchdog Output pulls low when the internal watchdog timer finishes its 1.6sec count and does not go high again until the watchdog is cleared. $\overline{\text{WDO}}$ also goes low during low-line conditions. Whenever $V_{\text{CC}}$ is below the reset threshold, $\overline{\text{WDO}}$ stays low; however, unlike $\overline{\text{RESET}}$ , $\overline{\text{WDO}}$ does not have a minimum pulse width. As soon as $V_{\text{CC}}$ rises above the reset threshold, $\overline{\text{WDO}}$ goes high with no delay.
RESET	Active-High Reset Output is the inverse of $\overline{\text{RESET}}$ . Whenever RESET is high, $\overline{\text{RESET}}$ is low, and vice versa.

**Absolute Maximum Ratings (Note 1)**

Symbol	Parameter	Value	Unit
V <sub>CC</sub>	Supply Voltage	-0.3 to +6.0	V
	RESET, $\overline{\text{RESET}}$ (Push-Pull)	-0.3 to V <sub>CC</sub> +0.3	V
I <sub>CC</sub>	Input Current, V <sub>CC</sub>	20	mA
I <sub>O</sub>	Output Current, RESET, $\overline{\text{RESET}}$	20	mA
	Rate of Rise, V <sub>CC</sub>	100	V/μs
P <sub>D</sub>	Continuous Power Dissipation	471	mW
T <sub>J</sub>	Operating Junction Temperature	-40 to +105	°C
T <sub>STG</sub>	Storage Temperature Range	-65 to +150	°C
	Lead Temperature (Soldering, 10s)	300	°C

Note 1: Stresses beyond those listed under “Absolute maximum Ratings” may cause permanent damage to the device.

**Electrical Characteristics**

V<sub>CC</sub>=full range, T<sub>A</sub>=-40 °C to +85 °C, unless otherwise noted. Typical values are at T<sub>A</sub>=+25 °C, V<sub>CC</sub>=5V for L/M versions, V<sub>CC</sub>=3.3V for T/S versions and V<sub>CC</sub>=3V for R version. (Note 2)

Symbol	Parameter	Conditions	Min	Typ	Max	Unit			
V <sub>CC</sub>	V <sub>CC</sub> Range	T <sub>A</sub> =0 °C to +70 °C	1.0		5.5	V			
		T <sub>A</sub> =-40 °C to +85 °C	1.2		5.5				
I <sub>CC</sub>	Supply Current	T <sub>A</sub> =-40 °C to +85 °C		80	150	μA			
V <sub>TH</sub>	Reset Threshold	UM706LS/UM706LM8 UM708LS/UM813LS	T <sub>A</sub> =+25 °C	4.53	4.63	4.73	V		
			T <sub>A</sub> =-40 °C to +85 °C	4.50		4.75			
		UM706MS/UM706MM8 UM708MS/UM813MS	T <sub>A</sub> =+25 °C	4.29	4.38	4.47			
			T <sub>A</sub> =-40 °C to +85 °C	4.25		4.50			
		UM706TS/UM706TM8 UM708TS/UM813TS	T <sub>A</sub> =+25 °C	3.01	3.08	3.15			
			T <sub>A</sub> =-40 °C to +85 °C	3.00		3.16			
		UM706SS/UM706SM8 UM708SS/UM813SS	T <sub>A</sub> =+25 °C	2.87	2.93	2.99			
			T <sub>A</sub> =-40 °C to +85 °C	2.85		3.00			
		UM706RS/UM706RM8 UM708RS/UM813RS	T <sub>A</sub> =+25 °C	2.57	2.63	2.69			
			T <sub>A</sub> =-40 °C to +85 °C	2.55		2.70			
			Reset Threshold Hysteresis		40				mV
		t <sub>RS</sub>	Reset Pulse Width		140	200		280	ms

Note 2: Production testing done at T<sub>A</sub>=+25 °C; limits over temperature guaranteed by design only.

**Electrical Characteristics (Continued)**

$V_{CC}$ =full range,  $T_A$ =-40 °C to +85 °C, unless otherwise noted. Typical values are at  $T_A$ =+25 °C,  $V_{CC}$ =5V for L/M versions,  $V_{CC}$ =3.3V for T/S versions and  $V_{CC}$ =3V for R version. (Note 2)

Symbol	Parameter	Conditions	Min	Typ	Max	Unit
$V_{OL}$	RESET/RESET Output Voltage Low	$I_{SINK}=1.2mA$ (for R/S/T versions)			0.3	V
		$I_{SINK}=3.2mA$ (for L/M versions)			0.4	
		$V_{CC}=1.2V$ , $I_{SINK}=100\mu A$			0.3	
$V_{OH}$	RESET/RESET Output Voltage High	$I_{SOURCE}=800\mu A$	$0.7V_{CC}$			V
	MR Pull-Up Current	MR=0V			600	$\mu A$
$t_{MR}$	MR Pulse Width		150			ns
	MR Input Threshold, Low				0.8	V
	MR Input Threshold, High		2.0			V
$t_{MD}$	MR to Reset Out Delay				250	ns
	PFI Input Threshold	$V_{CC}=5V$	1.20	1.25	1.30	V
	PFI Input Current		-25	0.01	+25	nA
	PFO Output Voltage	$I_{SOURCE}=800\mu A$	$0.7V_{CC}$			V
		$I_{SINK}=3.2mA$			0.4	
<b>Watchdog Function for UM706/UM813</b>						
$t_{WD}$	Watchdog Timeout Period		1.0	1.6	2.25	s
$t_{WP}$	WDI Pulse Width	$V_{IL}=0.4V$ , $V_{IH}=0.8V_{CC}$	50			ns
	WDI Input Threshold Low	$V_{CC}=5V$			0.8	V
	WDI Input Threshold High	$V_{CC}=5V$	3.5			V
	WDI Input Current	WDI= $V_{CC}$			10	$\mu A$
		WDI=0V	-10			
	WDO Output Voltage High	$I_{SOURCE}=800\mu A$	$0.7V_{CC}$			V
	WDO Output Voltage Low	$I_{SINK}=1.2mA$			0.4	V

Note 2: Production testing done at  $T_A$ =+25 °C; limits over temperature guaranteed by design only.

Block Diagram

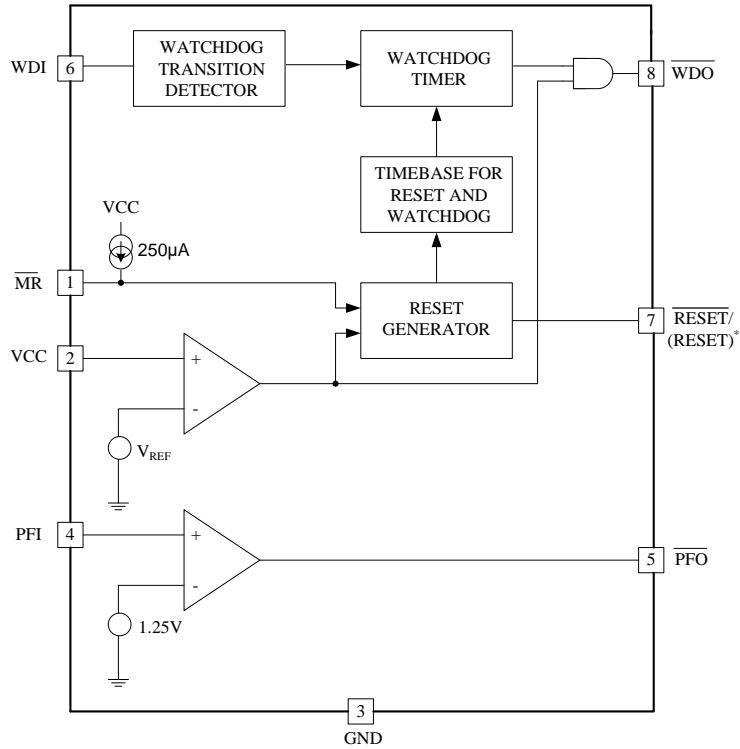

Figure 4. UM706xS/UM813xS Block Diagram (RESET)\* for UM813xS

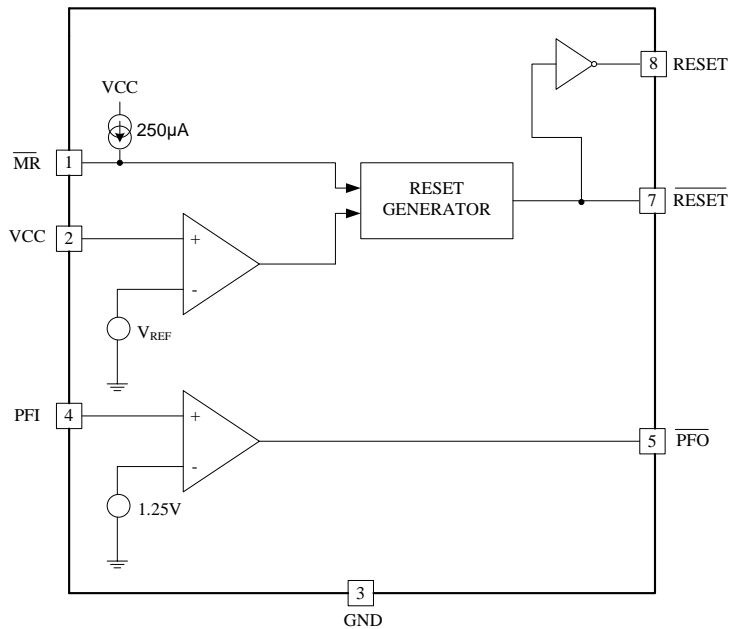
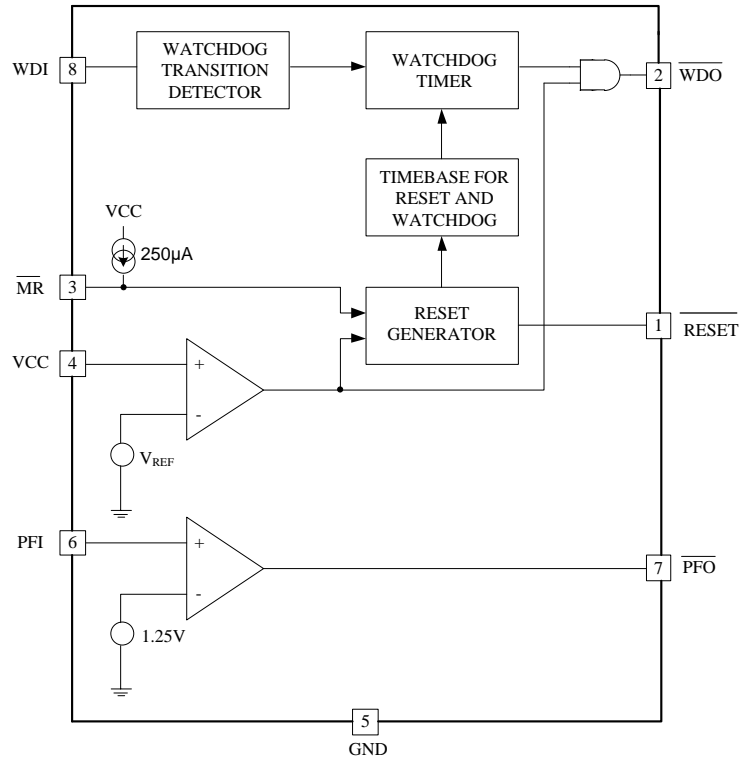

Figure 5. UM708xS Block Diagram

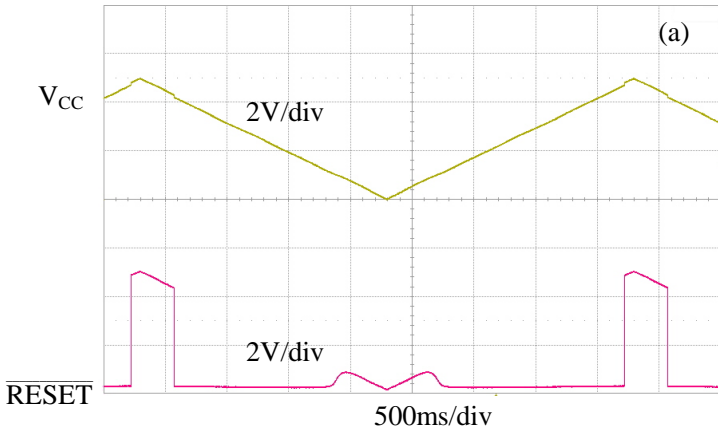



**Figure 6. UM706xM8 Block Diagram**

Typical Operating Characteristics

**RESET Output Voltage vs. Supply Voltage**



**RESET Response Time**

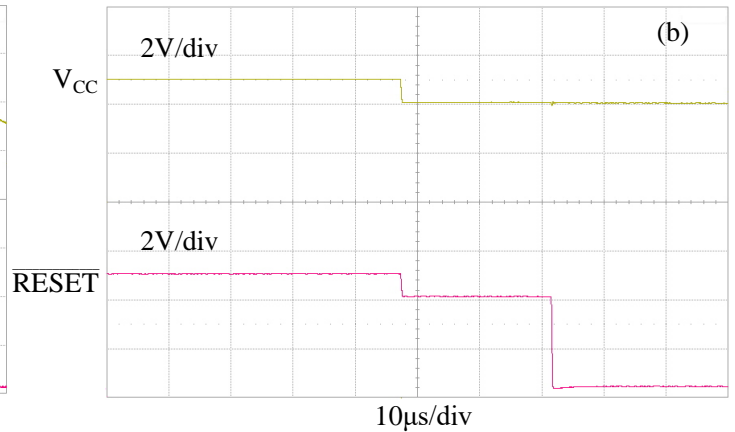

**Power-Fail Comparator Assertion Response Time**

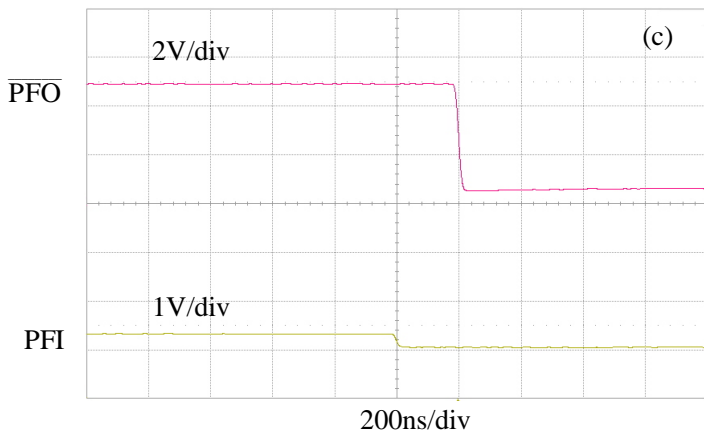

**Power-Fail Comparator De-assertion Response Time**

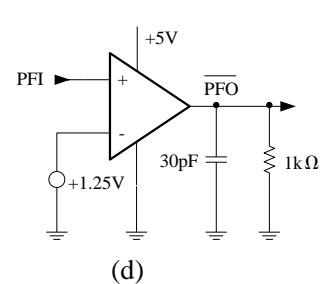
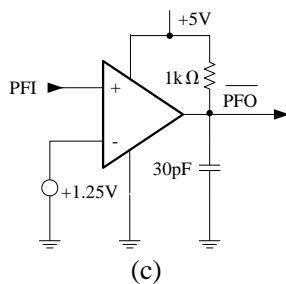
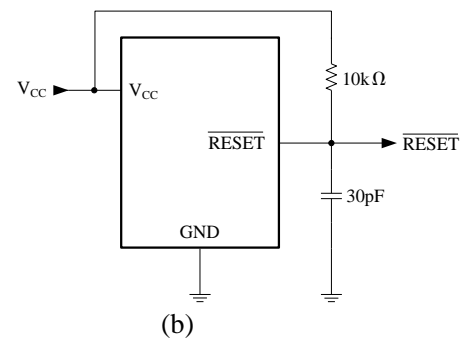
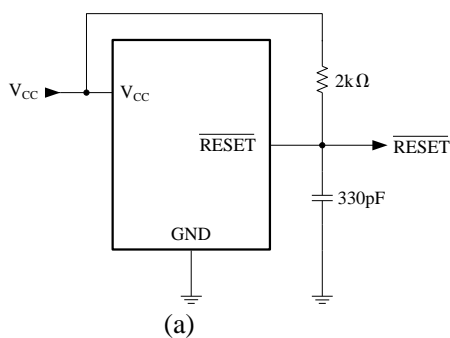
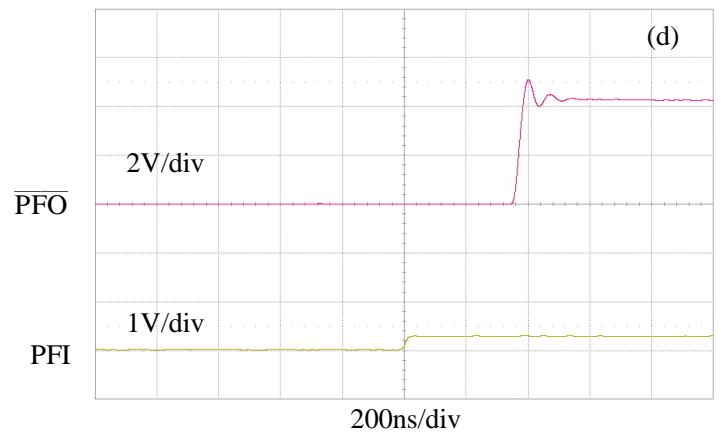

Typical Operating Characteristics (Continued)

RESET Output Voltage vs. Supply Voltage

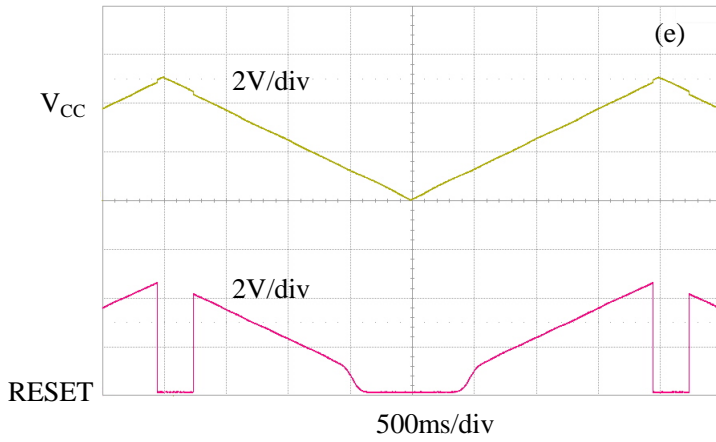

RESET Response Time

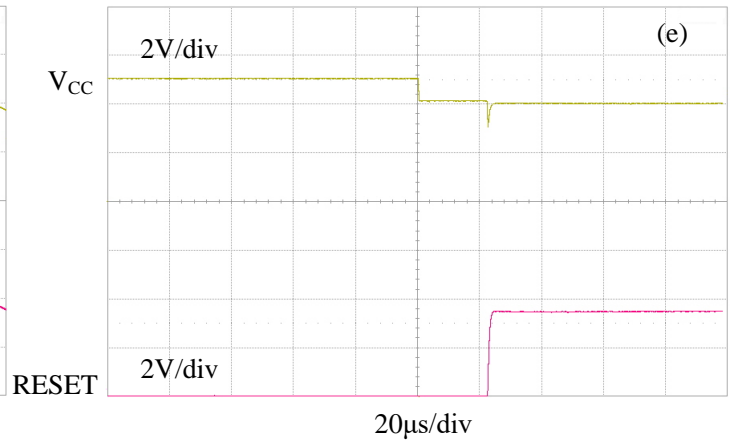

RESET,  $\overline{\text{RESET}}$  Assertion

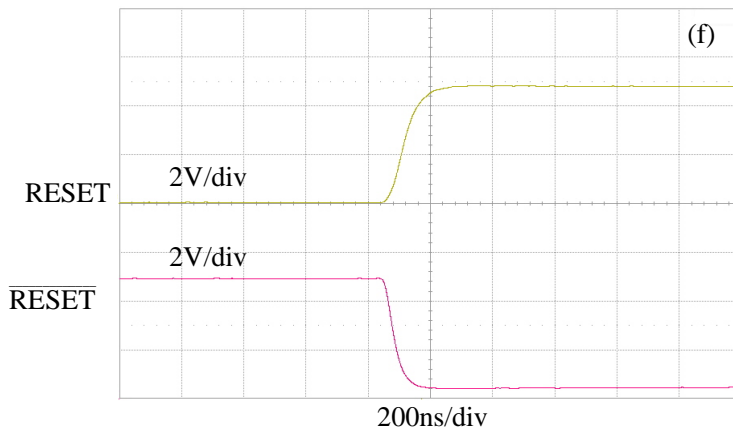

RESET,  $\overline{\text{RESET}}$  De-assertion

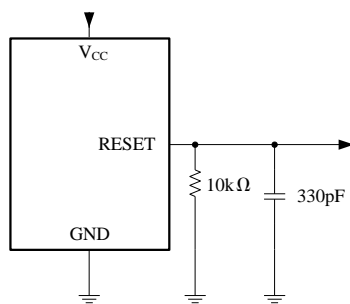
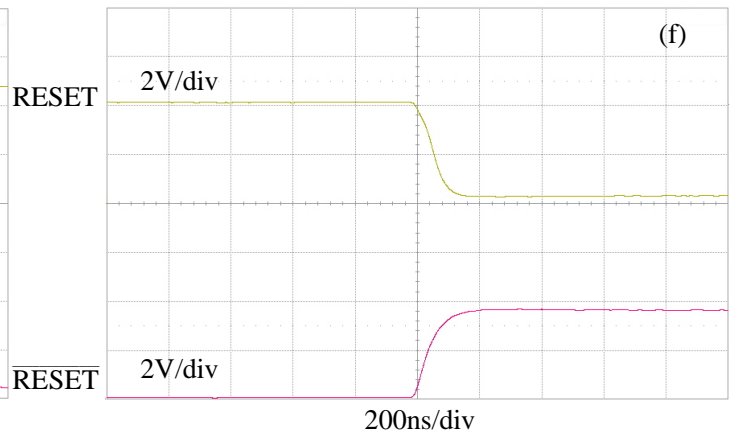

(e)

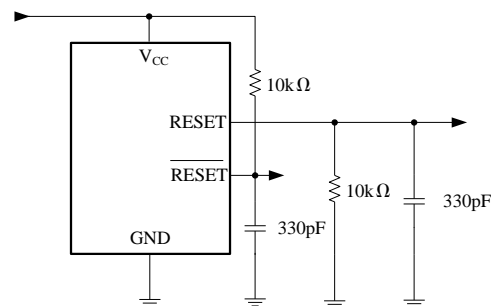

(f)

## Detailed Description

### Power-Fail Reset

The reset output provides a reset signal to the microprocessor whenever the  $V_{CC}$  input is below the threshold. An internal timer holds the reset output active for 200ms after the voltage on  $V_{CC}$  rises above the threshold. This is intended as a power-on reset signal for the microprocessor. It allows time for both the power supply and the microprocessor to stabilize after power-up. If a power supply brownout or interruption occurs, the reset line is similarly activated and remains active for 200ms after the supply recovers. If another interruption occurs during an active reset period, the reset timeout period continues for an additional 200ms.

The reset output is guaranteed to remain valid with  $V_{CC}$  as low as 1V. This ensures that the microprocessor is held in a stable shutdown condition as the power supply starts up.

The UM706xS/UM706xM8 provides an active low  $\overline{\text{RESET}}$  signal while the UM813xS provides an active high RESET signal. The UM708xS has both an active high RESET output and an active low  $\overline{\text{RESET}}$  output.

### Power-Fail Comparator

The power-fail comparator can be used for various purposes because its output and non-inverting input are not internally connected. The inverting input is internally connected to a 1.25V reference.

To build an early-warning circuit for power failure, connect the PFI pin to a voltage divider, choose the voltage divider ratio so that the voltage at PFI falls below 1.25V just before the regulator drops out. Use  $\overline{\text{PFO}}$  to interrupt the  $\mu\text{P}$  so it can prepare for an orderly power-down.

### Manual Reset

The Manual-Reset input ( $\overline{\text{MR}}$ ) allows reset to be triggered by a pushbutton switch. The switch is effectively debounced by the 140ms minimum reset pulse width.  $\overline{\text{MR}}$  is TTL/CMOS logic compatible, so it can be driven by an external logic line. If unused,  $\overline{\text{MR}}$  input can be tied high or left floating.

### Watchdog Timer

The UM706xS/UM706xM8/UM813xS watchdog circuit monitors the  $\mu\text{P}$ 's activity. If the  $\mu\text{P}$  does not toggle the watchdog input (WDI) within 1.6sec and WDI is not three-stated,  $\overline{\text{WDO}}$  goes low. As long as  $\overline{\text{RESET}}$  is asserted or the WDI input is three-stated, the watchdog timer will stay cleared and will not count. As soon as reset is released and WDI is driven high or low, the timer will start counting. Pulses as short as 50ns can be detected.

Typically,  $\overline{\text{WDO}}$  will be connected to the non-maskable interrupt input (NMI) of a  $\mu\text{P}$ . When  $V_{CC}$  drops below the reset threshold,  $\overline{\text{WDO}}$  will go low whether or not the watchdog timer has timed out yet. Normally this would trigger an NMI interrupt, but  $\overline{\text{RESET}}$  goes low simultaneously, and thus overrides the NMI interrupt.

If WDI is left unconnected,  $\overline{\text{WDO}}$  can be used as a low-line output. Since floating WDI disables the internal timer,  $\overline{\text{WDO}}$  goes low only when  $V_{CC}$  falls below the reset threshold, thus functioning as a low-line output.

The UM706xS/UM706xM8 has a watchdog timer and a  $\overline{\text{RESET}}$  output. The UM708xS has both active-high and active-low reset outputs. The UM813xS has both an active-high reset output and a watchdog timer.

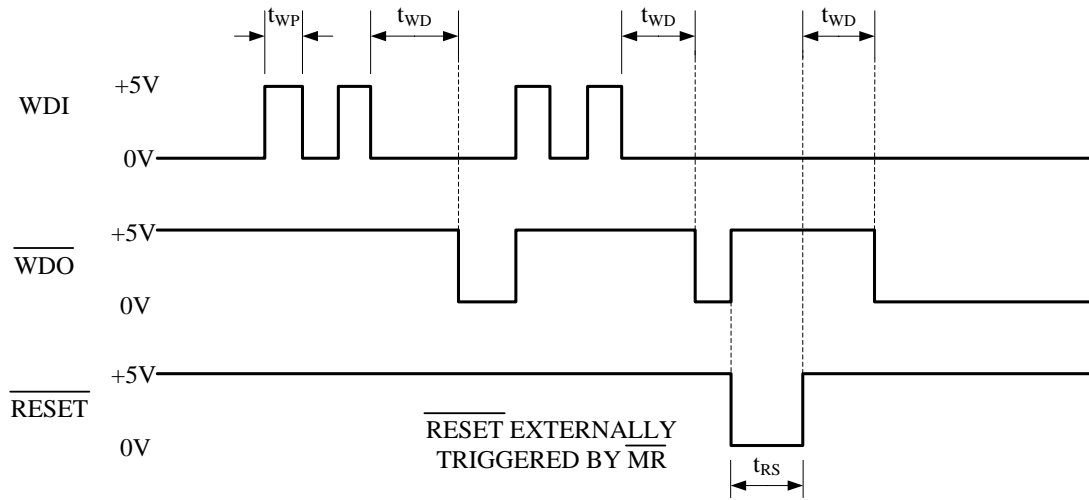

Figure 7. Watchdog and Reset Timing

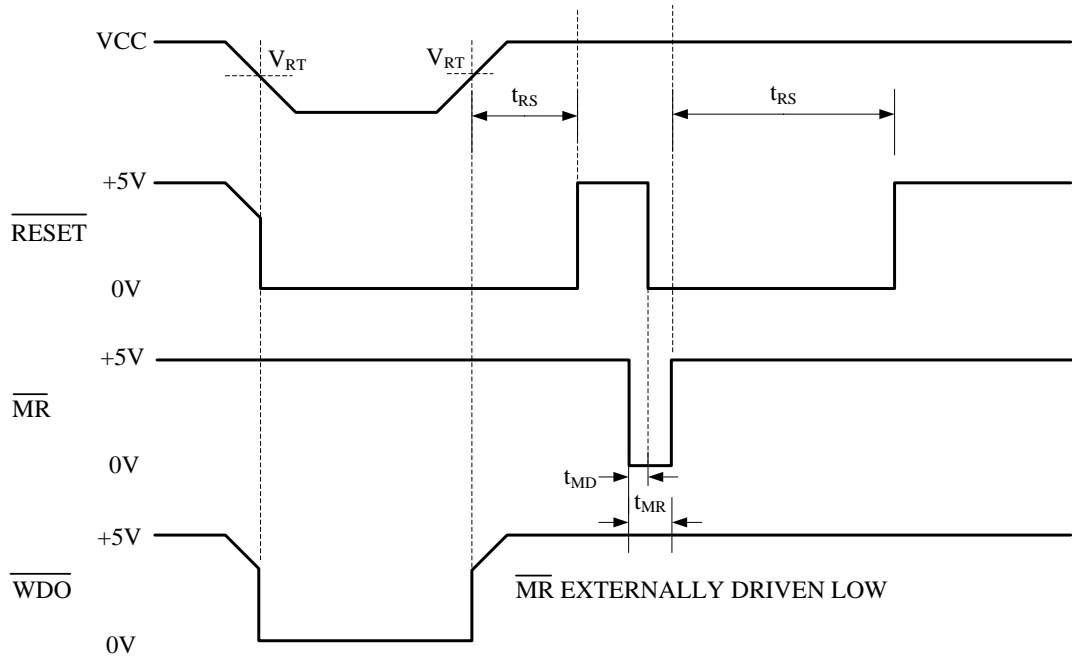

Figure 8. Reset, Manual Reset and Watchdog Timing

## Applications Information

### Valid $\overline{\text{RESET}}$ below 1V $V_{CC}$

The UM706xS/UM706xM8/UM708xS/UM813xS are guaranteed to provide a valid reset level with  $V_{CC}$  as low as 1V. When  $V_{CC}$  falls below 1V, the internal transistor does not have sufficient drive to hold it on so the voltage on  $\overline{\text{RESET}}$  is no longer held at 0V. If a pull-down resistor is added to the  $\overline{\text{RESET}}$  pin as shown in Figure 9, any stray charge or leakage current will be drained to ground, holding  $\overline{\text{RESET}}$  low. Resistor value (R1) is not critical. It should be about 100k $\Omega$ , large enough not to load  $\overline{\text{RESET}}$  and small enough to pull  $\overline{\text{RESET}}$  to ground.

### Monitoring Additional Supply Levels

It is possible to use the power-fail comparator to monitor a second supply as shown in Figure 10. The two sensing resistors, R1 and R2, are selected such that the voltage on PFI drops below 1.25V at the minimum acceptable input supply. The  $\overline{\text{PFO}}$  output can be connected to the  $\overline{\text{MR}}$  input so that a reset is generated when the supply drops out of tolerance. In this case, if either supply drops out of tolerance, a reset is generated.

### Monitoring a Negative Voltage

The power-fail comparator can also monitor a negative supply rail (Figure 11). When the negative rail is good (a negative voltage of large magnitude),  $\overline{\text{PFO}}$  is low, and when the negative rail is degraded (a negative voltage of lesser magnitude),  $\overline{\text{PFO}}$  is high. By adding the resistors and transistor as shown, a high  $\overline{\text{PFO}}$  triggers reset. As long as  $\overline{\text{PFO}}$  remains high, the UM706xS/UM706xM8/UM708xS/UM813xS will keep reset asserted ( $\overline{\text{RESET}}$  =low, RESET=high). Note that this circuit's accuracy depends on the PFI threshold tolerance, the  $V_{CC}$  line, and the resistors.

### Microprocessor with Bidirectional Reset

To prevent contention for microprocessors with a bidirectional reset line, a current limiting resistor is to be inserted between the  $\overline{\text{RESET}}$  output pin and the microprocessor reset pin. This limits the current to a safe level if there are conflicting output reset levels. A suitable resistor value is 4.7k $\Omega$ . If the reset output is required for other uses, it should be buffered as shown in Figure 12.

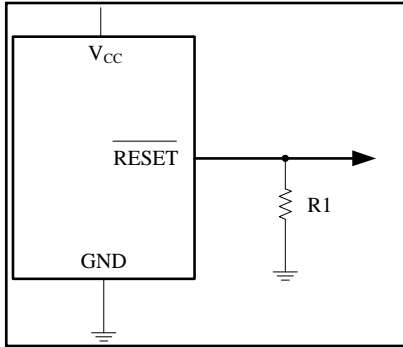

Figure 9. Reset Valid to Ground Circuit  $V_x$

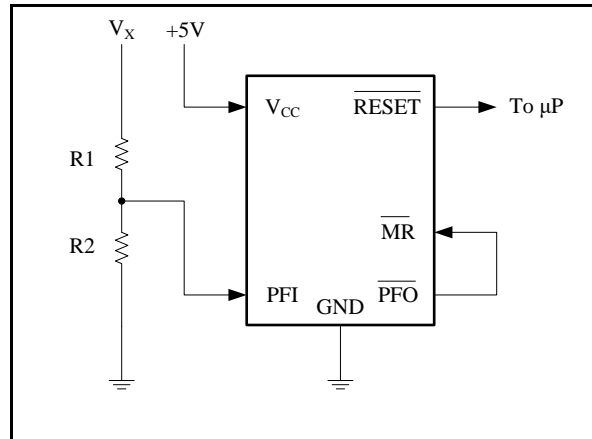

Figure 10. Monitoring an Additional Supply  $V_x$

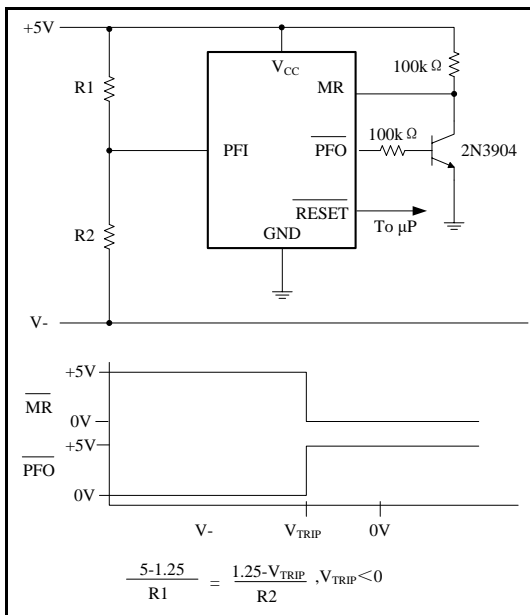

Figure 11. Monitoring a Negative Voltage

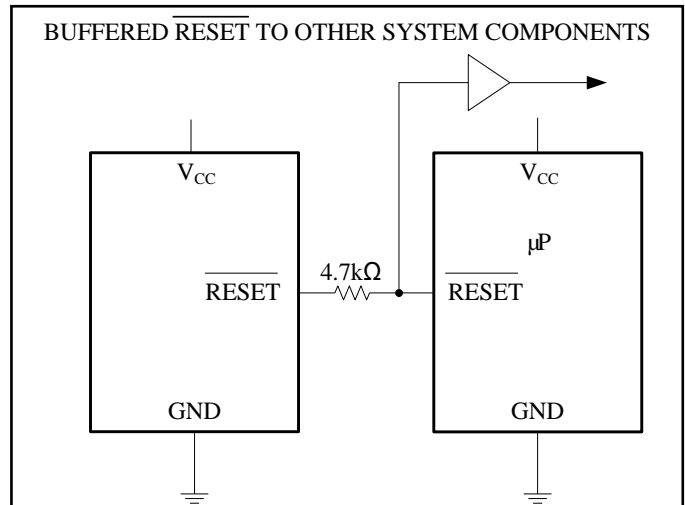
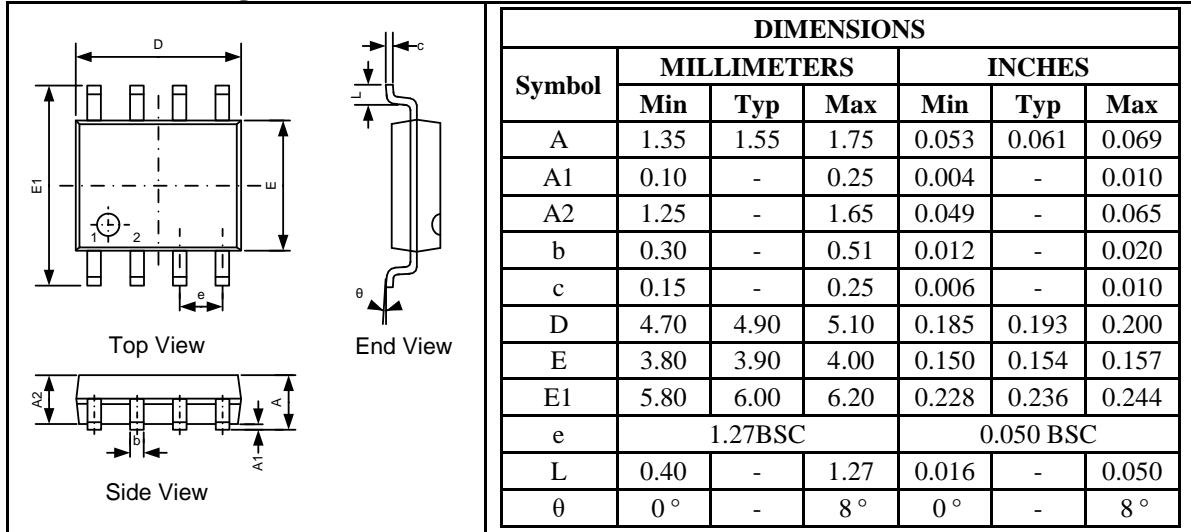

Figure 12. Bidirectional Reset I/O

**Package Information**

**UM706xS SOP8**

**Outline Drawing**



**Land Pattern**

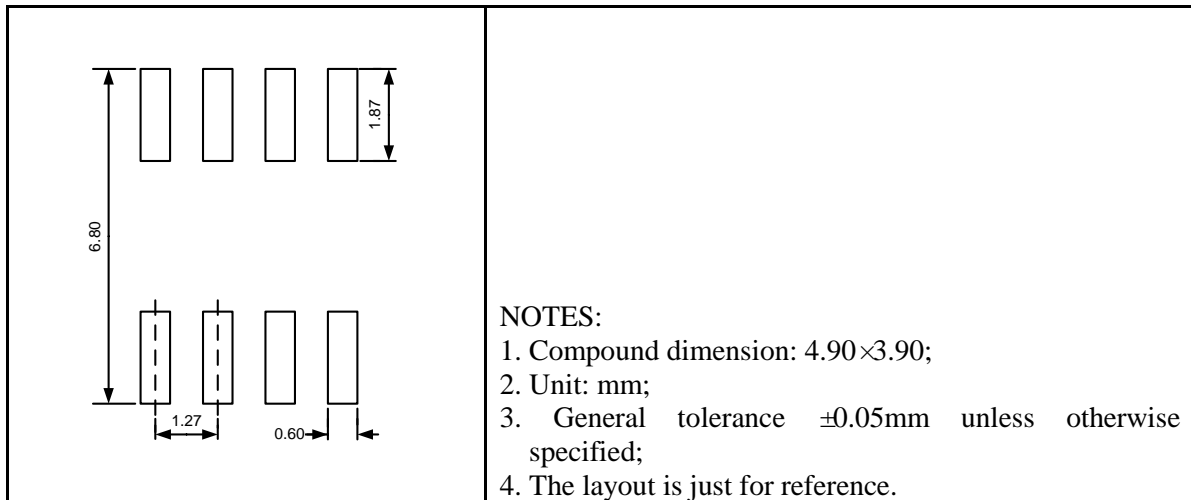

**Tape and Reel Orientation**

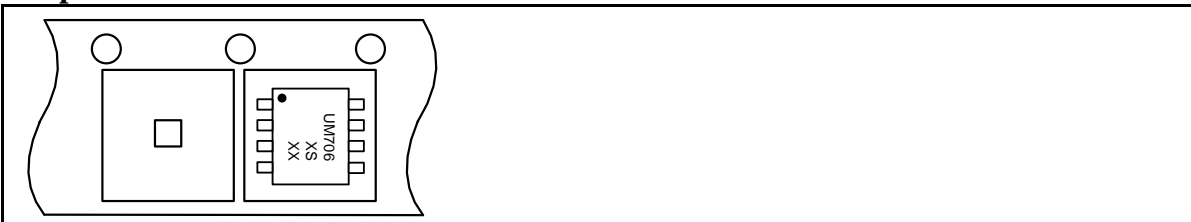



UM706xM8 MSOP8

Outline Drawing

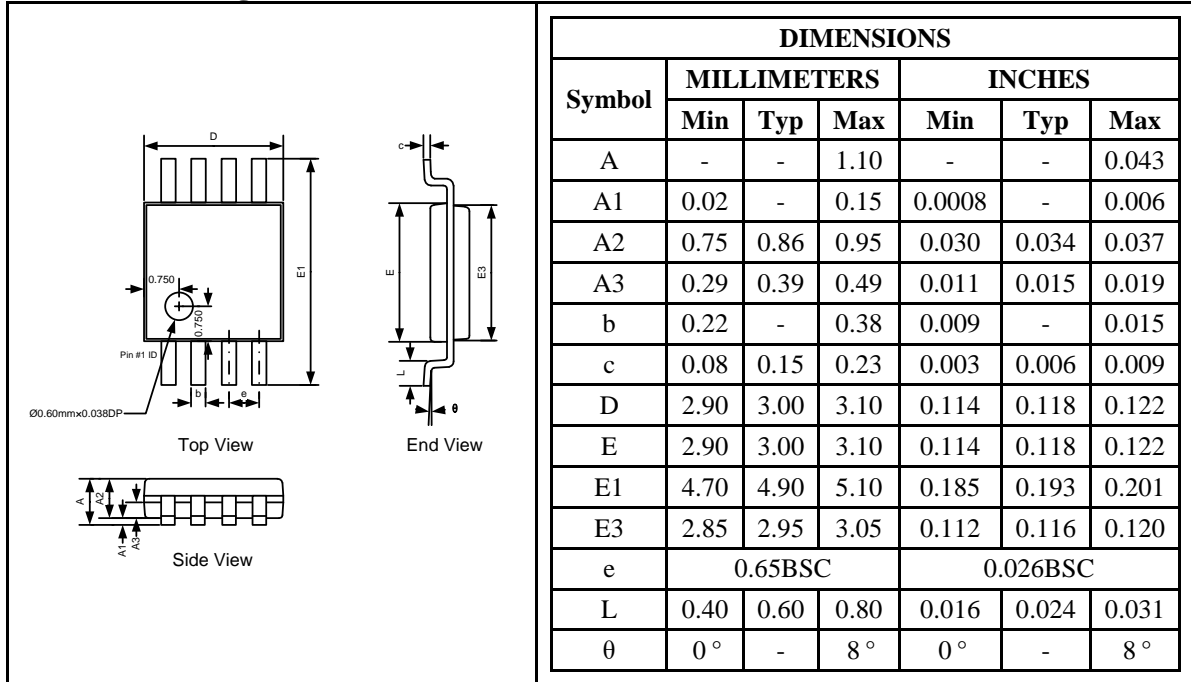

Land Pattern

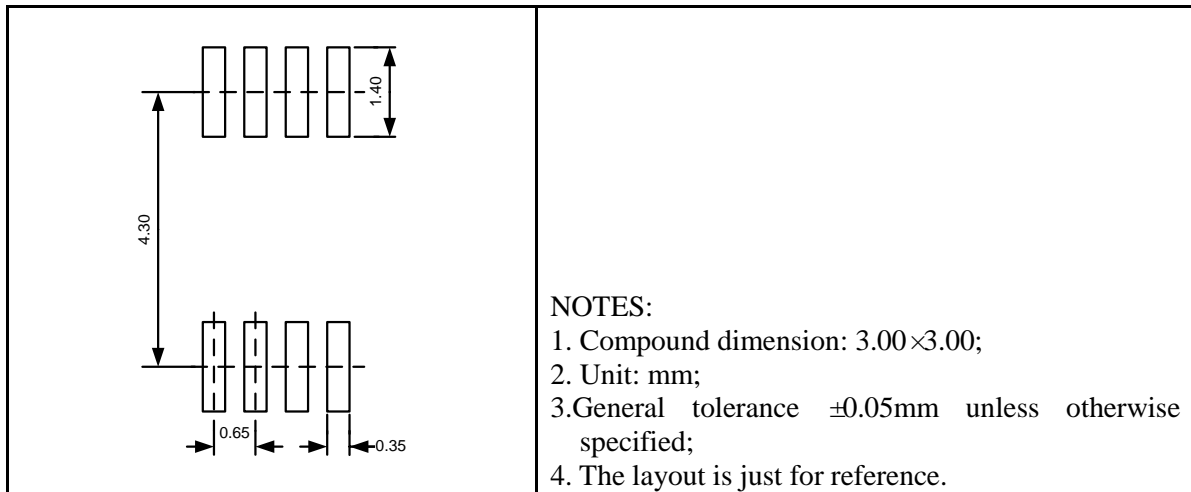

Tape and Reel Orientation

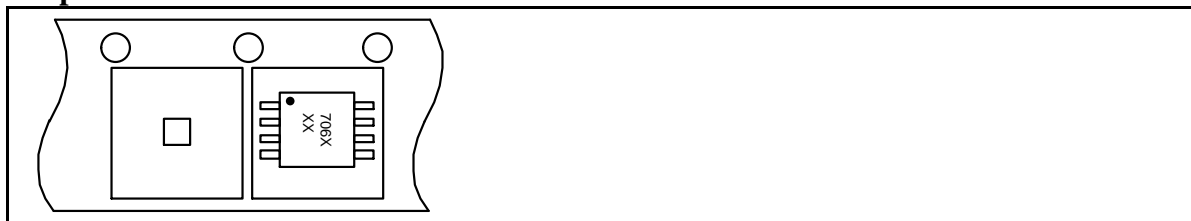

UM708xS SOP8

Outline Drawing

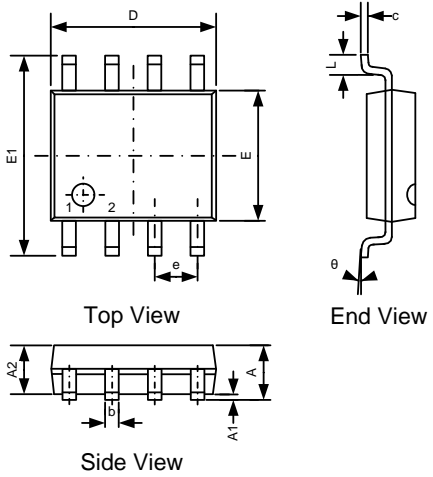

DIMENSIONS						
Symbol	MILLIMETERS			INCHES		
	Min	Typ	Max	Min	Typ	Max
A	1.35	1.55	1.75	0.053	0.061	0.069
A1	0.10	-	0.25	0.004	-	0.010
A2	1.25	-	1.65	0.049	-	0.065
b	0.30	-	0.51	0.012	-	0.020
c	0.15	-	0.25	0.006	-	0.010
D	4.70	4.90	5.10	0.185	0.193	0.200
E	3.80	3.90	4.00	0.150	0.154	0.157
E1	5.80	6.00	6.20	0.228	0.236	0.244
e	1.27BSC			0.050 BSC		
L	0.40	-	1.27	0.016	-	0.050
$\theta$	0°	-	8°	0°	-	8°

Land Pattern

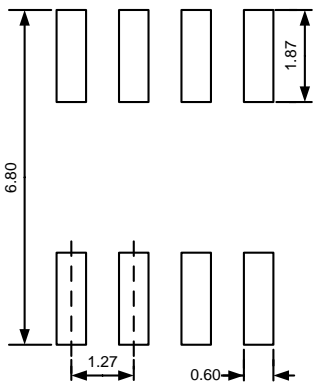

NOTES:

1. Compound dimension: 4.90×3.90;
2. Unit: mm;
3. General tolerance  $\pm 0.05\text{mm}$  unless otherwise specified;
4. The layout is just for reference.

Tape and Reel Orientation

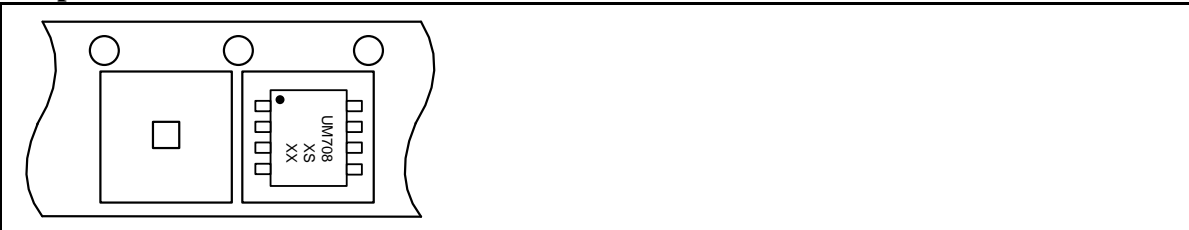

**UM813xS SOP8**

**Outline Drawing**

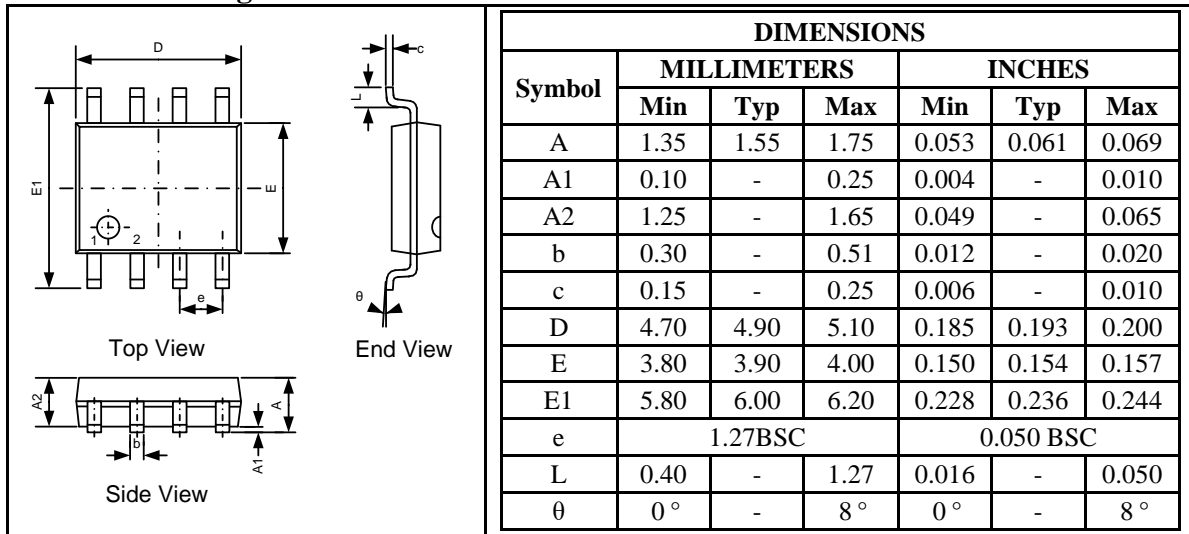

**Land Pattern**

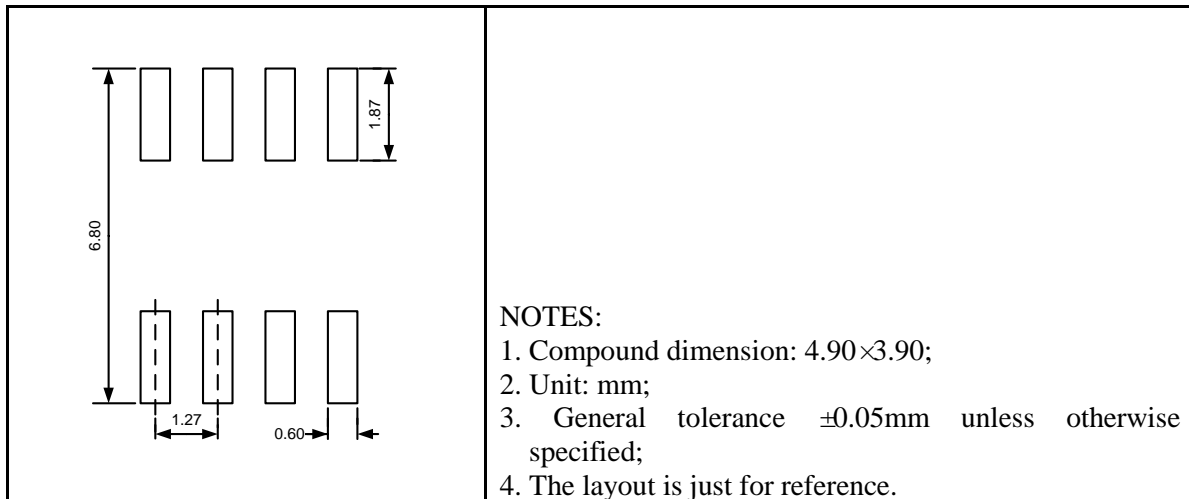

**Tape and Reel Orientation**

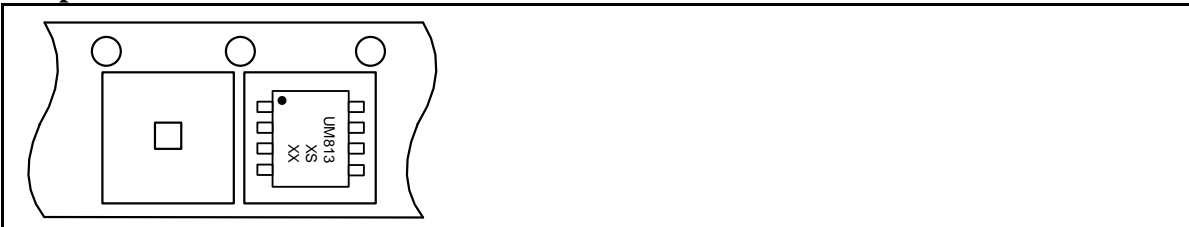

**Packing Information**

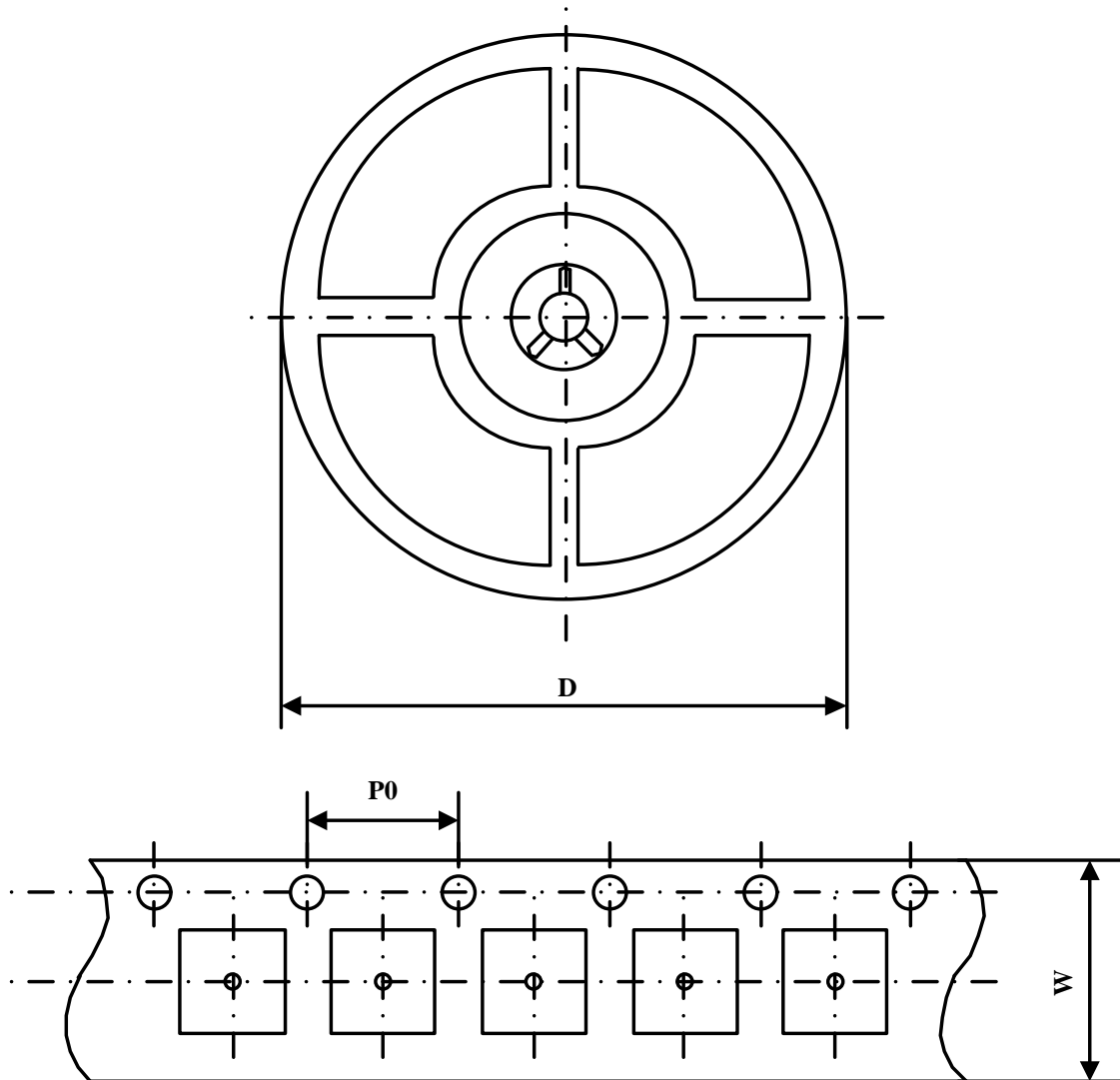

Part Number	Package Type	Carrier Width(W)	Pitch(P0)	Reel Size(D)
UM706xS	SOP8	12 mm	4 mm	330 mm
UM706xM8	MSOP8	12 mm	4 mm	330 mm
UM708xS	SOP8	12 mm	4 mm	330 mm
UM813xS	SOP8	12 mm	4 mm	330 mm

## **GREEN COMPLIANCE**

Union Semiconductor is committed to environmental excellence in all aspects of its operations including meeting or exceeding regulatory requirements with respect to the use of hazardous substances. Numerous successful programs have been implemented to reduce the use of hazardous substances and/or emissions.

All Union components are compliant with the RoHS directive, which helps to support customers in their compliance with environmental directives. For more green compliance information, please visit:

[http://www.union-ic.com/index.aspx?cat\\_code=RoHSDeclaration](http://www.union-ic.com/index.aspx?cat_code=RoHSDeclaration)

## **IMPORTANT NOTICE**

The information in this document has been carefully reviewed and is believed to be accurate. Nonetheless, this document is subject to change without notice. Union assumes no responsibility for any inaccuracies that may be contained in this document, and makes no commitment to update or to keep current the contained information, or to notify a person or organization of any update. Union reserves the right to make changes, at any time, in order to improve reliability, function or design and to attempt to supply the best product possible.