

5V, Fail-Safe, RS-422 Transceivers

UM13087S8 SOP8

General Description

The UM13087S8 is $\pm 15\text{kV}$ electrostatic discharge (ESD)-protected, high-speed transceivers for RS-422 communication that contain one driver and one receiver. The device features fail-safe circuitry, which guarantees a logic-high receiver output when the receiver inputs are open or shorted. This means that the receiver output will be a logic high if all transmitters on a terminated bus are disabled (high impedance). The UM13087S8 allows transmit speeds up to 10Mbps. The device features enhanced ESD protection. All transmitter outputs and receiver inputs are protected to $\pm 15\text{kV}$ using the Human Body Model.

The device has a 1/8-unit-load receiver input impedance that allows up to 256 transceivers on the bus. The UM13087S8 is intended for full-duplex communications.

Applications

- RS-422 Communications
- Level Translators
- Transceivers for EMI-Sensitive Applications
- Industrial-Control Local Area Networks

Features

- ESD Protection for RS-422 I/O Pins $\pm 15\text{kV}$, Human Body Model
- True Fail-Safe Receiver while Maintaining EIA/TIA-422 Compatibility
- Maximum Data Rate up to 10Mbps
- Error-Free Data Transmission
- Allow up to 256 Transceivers on the Bus

Selector Guide

Part Number	Half/Full Duplex	Data Rate (Mbps)	Slew-Rate Limited	Low-Power Shutdown	Receiver/Driver Enable	Transceivers On Bus	Pin Count
UM13087S8	full	10	No	No	No	256	8

Ordering Information

Part Number	Temperature Range	Packaging Type	Shipping Qty
UM13087S8	-40 °C to +85 °C	SOP8	3000pcs/13 Inch Tape & Reel

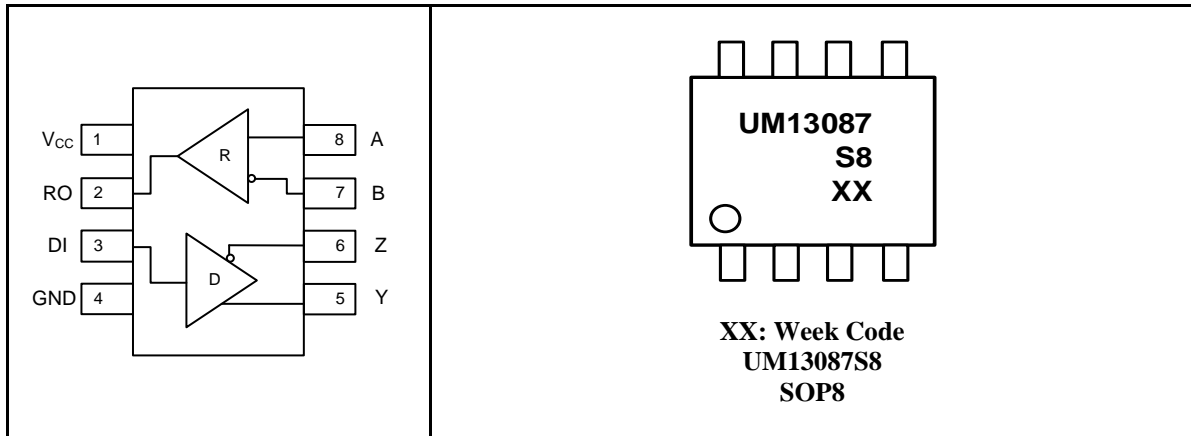
Pin Configurations
Top View

Absolute Maximum Ratings

Symbol	Parameter	Value	Unit
V _{CC}	Supply Voltage	6	V
	Driver Input Voltage (DI)	-0.3V to (VCC + 0.3V)	V
	Driver Output Voltage (Y, Z)	-7.5 to +12.5	V
	Receiver Input Voltage (A, B)	-7.5 to +12.5	V
	Receiver Output Voltage (RO)	-0.3V to (VCC + 0.3V)	V
P _D	8-Pin SO (derate 9.09mW/ °C above +70 °C)	520	mW
T _A	Ambient Temperature	-40 to +85	°C
T _J	Junction Temperature	-40 to +150	°C
T _{STG}	Storage Temperature Range	-65 to +150	°C
T _L	Lead Temperature for Soldering 10 seconds	+300	°C

Thermal Information

Symbol	Thermal Metric		Value	UNIT
R _{θJA}	Junction to Ambient Thermal Resistance	SOP8	110	°C/W
R _{θJC}	Junction to Case Thermal Resistance	SOP8	54	

DC Electrical Characteristics

($V_{CC} = 5V \pm 5\%$, $T_A = T_{MIN}$ to T_{MAX} , unless otherwise noted. Typical values are at $V_{CC} = 5V$ and $T_A = +25\text{ }^\circ\text{C}$.) (Note 1)

Parameter	Symbol	Test Conditions	Min	Typ	Max	Unit
DRIVER						
Differential Driver Output	V_{OD1}	Figure 3, No Load			V_{CC}	V
Differential Driver Output	V_{OD2}	Figure 3, $R = 50\Omega$	2.0		V_{CC}	V
Differential Driver Output	V_{OD3}	Figure 3, $R = 27\Omega$	1.5		V_{CC}	V
Change-in-Magnitude of Differential Output Voltage (Note 2)	ΔV_{OD}	Figure 3, $R = 50\Omega$			0.2	V
Driver Common-Mode Output Voltage	V_{OC}	Figure 3, $R = 50\Omega$			3.0	V
Input High Voltage	V_{IH}	DI	2.0			V
Input Low Voltage	V_{IL}	DI			0.8	V
DI Input Hysteresis	V_{HYS}			100		mV
Driver Short-Circuit Output Current (Note 3)	V_{OD1}	$-7V \leq V_{OUT} \leq 12V$	-550		550	mA
RECEIVER						
Input Current (A and B)	I_{IN}	$V_{IN} = 12V$			125	μA
		$V_{IN} = -7V$			-75	
Receiver Differential Threshold Voltage	V_{TH}	$-7V \leq V_{CM} \leq 12V$	-200	-125	-50	mV
Receiver Input Hysteresis	ΔV_{TH}			25		mV
Receiver Output High Voltage	V_{OH}	$I_O = -4\text{mA}$, $V_{ID} = -50\text{mV}$	4			V
Receiver Output Low Voltage	V_{OL}	$I_O = 4\text{mA}$, $V_{ID} = -200\text{mV}$			0.4	V
Receiver Input Resistance	R_{IN}	$-7V \leq V_{CM} \leq 12V$	96			$\text{k}\Omega$
Receiver Output Short Circuit Current	I_{OSR}	$0V \leq V_{RO} \leq V_{CC}$	7		95	mA
SUPPLY CURRENT						
Supply Current	I_{CC}	No load, DI=GND or V_{CC}		600	900	μA
ESD Protection for Y, Z, A, B		Human Body Model		± 15		kV

Note 1: All currents into the device are positive; all currents out of the device are negative. All

voltages are referred to device ground unless otherwise noted.

Note 2: ΔV_{OD} and ΔV_{OC} are the changes in V_{OD} and V_{OC} , respectively, when the DI input changes state.

Note 3: Maximum current level applies to peak current just prior to foldback-current limiting; minimum current level applies during current limiting.

Switching Characteristics

($V_{CC} = 5V \pm 5\%$, $T_A = T_{MIN}$ to T_{MAX} , unless otherwise noted. Typical values are at $V_{CC} = 5V$ and $T_A = +25\text{ }^\circ\text{C}$.)

Parameter	Symbol	Test Conditions	Min	Typ	Max	Unit
Driver Input-to-Output	t_{DPLH}	Figures 4 and 5, $R_{DIFF} = 54\Omega$, $C_{L1} = C_{L2} = 100\text{pF}$		25	60	ns
	t_{DPHL}			25	60	
Driver Output Skew $ t_{DPLH} - t_{DPHL} $	t_{DSKEW}	Figures 4 and 5, $R_{DIFF} = 54\Omega$, $C_{L1} = C_{L2} = 100\text{pF}$		5	20	ns
Driver Rise or Fall Time	t_{DR}, t_{DF}	Figures 4 and 5, $R_{DIFF} = 54\Omega$, $C_{L1} = C_{L2} = 100\text{pF}$		10	20	ns
Maximum Data Rate	f_{MAX}			10		Mbps
Receiver Input to Output	t_{RPLH} , t_{RPHL}	Figures 6 and 7; $ V_{ID} \geq 2.0V$; rise and fall time of $V_{ID} \leq 15\text{ns}$	20	100	180	ns
$ t_{RPLH} - t_{RPHL} $ Differential Receiver Skew	t_{RSKD}	Figures 6 and 7; $ V_{ID} \geq 2.0V$; rise and fall time of $V_{ID} \leq 15\text{ns}$		10	30	ns

Pin Description

Pin Number	Symbol	Function
1	VCC	Power Supply
2	RO	Receiver Output. if $A - B \geq -50\text{mV}$, RO will be high; if $A - B \leq -200\text{mV}$, RO will be low
3	DI	Driver Input, a low on DI forces Y low and Z high. Similarly, a high on DI forces Y high and Z low
4	GND	Ground
5	Y	Non-inverting Driver Output
6	Z	Inverting Driver Output
7	B	Inverting Receiver Input
8	A	Non-inverting Receiver Input

Typical Operating Circuit

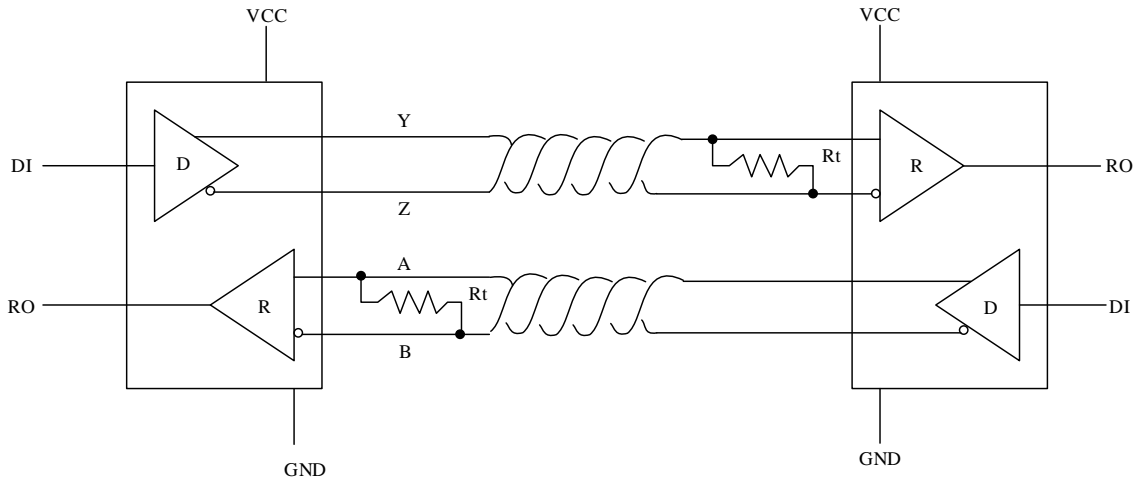

Figure 1: UM13087S8 pin configuration and typical full-duplex operating circuit

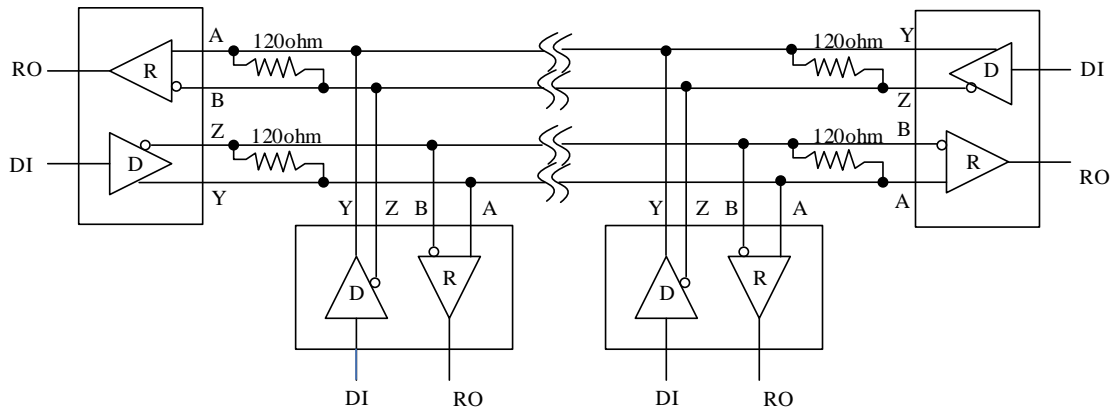

Figure 2: Typical Full-Duplex RS-422 Network

Detailed Description

The UM13087S8 high-speed transceivers for RS-422 communication contain one driver and one receiver. The device features fail-safe circuitry, which guarantees a logic-high receiver output when the receiver inputs are open or shorted, or when they are connected to a terminated transmission line with all drivers disabled.

The UM13087S8 is full-duplex transceiver. It operates from a single 5V supply. Drivers are output short-circuit current limited. Thermal shutdown circuitry protects drivers against excessive power dissipation. When activated, the thermal shutdown circuitry places the driver outputs into a high-impedance state.

Receiver Input Filtering

The receivers of the UM13087S8 incorporate input filtering in addition to input hysteresis. This filtering enhances noise immunity with differential signals that have very slow rise and fall times. Receiver propagation delay increases by 20% due to this filtering.

Fail-Safe

The UM13087S8 guarantees a logic-high receiver output when the receiver inputs are shorted or open, or when they are connected to a terminated transmission line with all drivers disabled. This is done by setting the receiver threshold between -50mV and -200mV. If the differential receiver input voltage (A-B) is greater than or equal to -50mV, RO is logic high. If A-B is less than or equal to -200mV, RO is logic low. In the case of a terminated bus with all transmitters disabled, the receiver's differential input voltage is pulled to 0V by the termination. With the receiver thresholds of the UM13087S8, this results in a logic high with a 50mV minimum noise margin. Unlike previous fail-safe devices, the -50mV to -200mV threshold complies with the $\pm 200\text{mV}$ EIA/TIA-422 standard.

 $\pm 15\text{kV}$ ESD Protection

As with all Union devices, ESD-protection structures are incorporated on all pins to protect against electrostatic discharges encountered during handling and assembly. The driver outputs and receiver inputs of the UM13087S8 have extra protection against static electricity. Union's engineers have developed state-of-the-art structures to protect these pins against ESD of $\pm 15\text{kV}$ without damage.

The ESD-protected pins are tested with reference to the ground pin in a powered-down condition. They are tested to $\pm 15\text{kV}$ using the Human Body Model.

Test Circuit

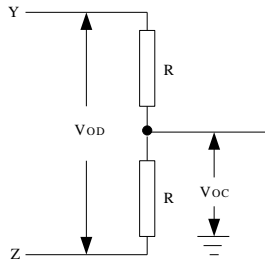

Figure 3. Driver DC Test Load

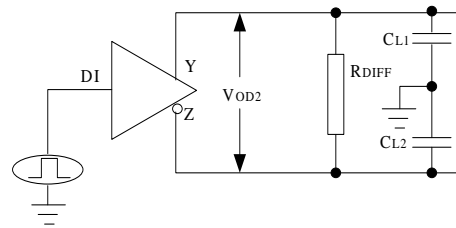

Figure 4. Driver Timing Test Circuit

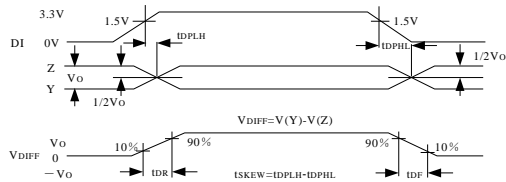

Figure 5. Driver Propagation Delays

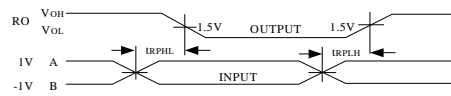

Figure 6. Receiver Propagation Delays

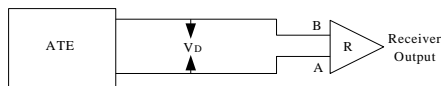

Figure 7. Receiver Propagation Delay Test Circuit

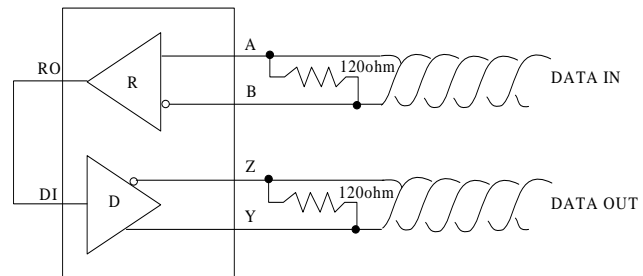

Figure 8: Line Repeater

Applications Information

256 Transceivers on the Bus

The standard RS-422 receiver input impedance is 12kΩ (one-unit load), and the standard driver can drive up to 32 unit loads. The UM13087S8 has a 1/8-unit-load receiver input impedance (96kΩ), allowing up to 256 transceivers to be connected in parallel on one communication line. Any combination of these devices and/or other RS-422 transceivers with a total of 32 unit loads or less can be connected to the line.

Driver Output Protection

Two mechanisms prevent excessive output current and power dissipation caused by faults or by bus contention. The first, a foldback current limit on the output stage, provides immediate protection against short circuits over the whole common-mode voltage range. The second, a thermal shutdown circuit, forces the driver outputs into a high-impedance state if the die temperature becomes excessive.

Line Length vs. Data Rate

The RS-422 standard covers line lengths up to 4000 feet. For line lengths greater than 4000 feet, use the repeater application shown in Figure 8.

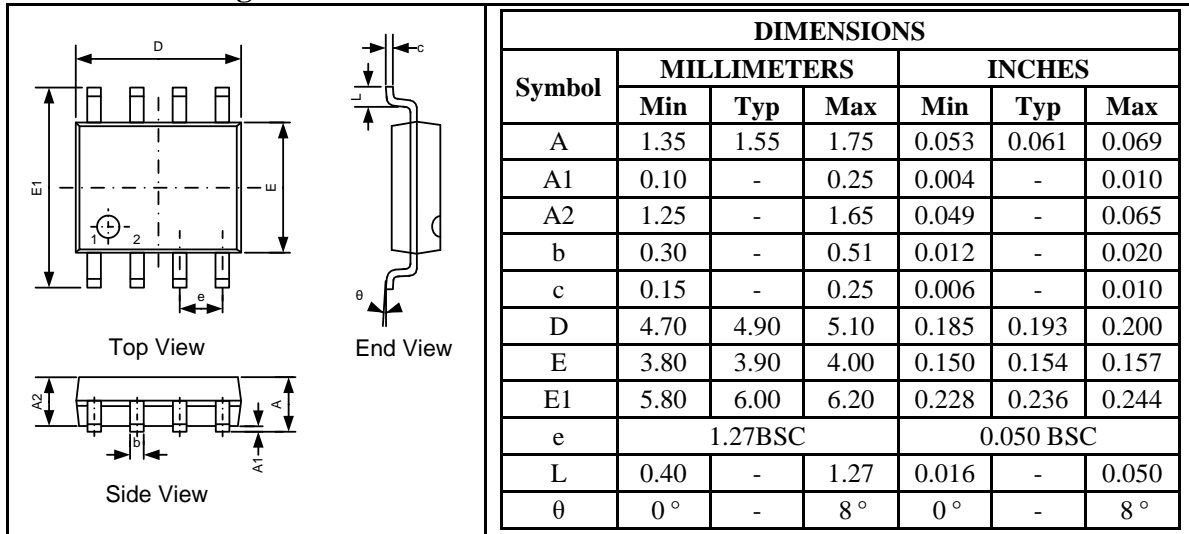
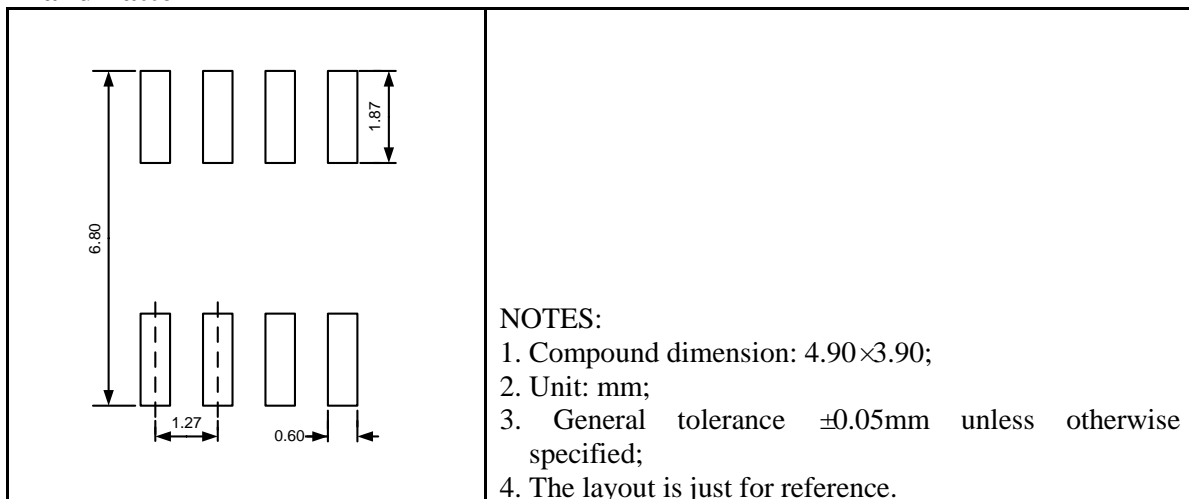
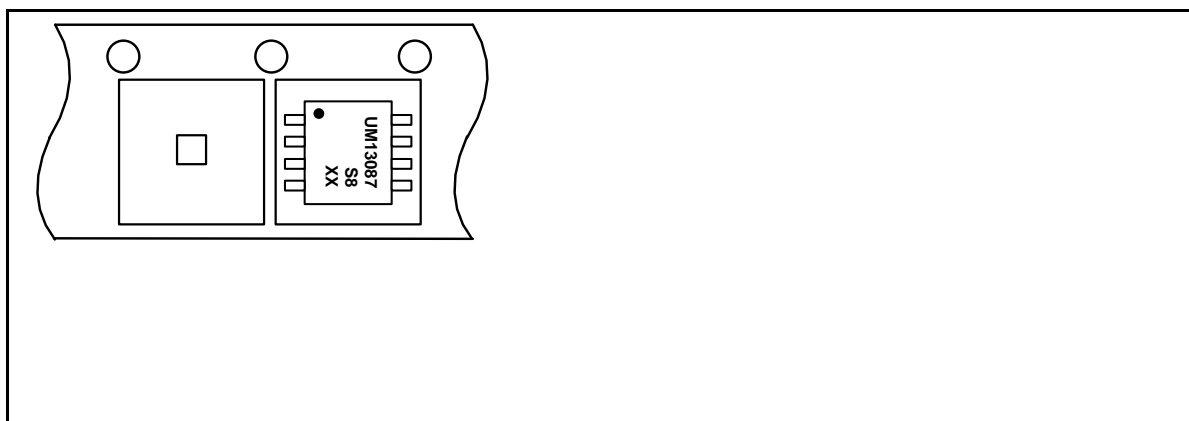
Package Information
UM13087S8 SOP8
Outline Drawing

Land Pattern

Tape and Reel Orientation

GREEN COMPLIANCE

Union Semiconductor is committed to environmental excellence in all aspects of its operations including meeting or exceeding regulatory requirements with respect to the use of hazardous substances. Numerous successful programs have been implemented to reduce the use of hazardous substances and/or emissions.

All Union components are compliant with the RoHS directive, which helps to support customers in their compliance with environmental directives. For more green compliance information, please visit:

http://www.union-ic.com/index.aspx?cat_code=RoHSDeclaration

IMPORTANT NOTICE

The information in this document has been carefully reviewed and is believed to be accurate. Nonetheless, this document is subject to change without notice. Union assumes no responsibility for any inaccuracies that may be contained in this document, and makes no commitment to update or to keep current the contained information, or to notify a person or organization of any update. Union reserves the right to make changes, at any time, in order to improve reliability, function or design and to attempt to supply the best product possible.



Union Semiconductor, Inc

Add: Unit 606, No.570 Shengxia Road, Shanghai 201210

Tel: 021-51093966

Fax: 021-51026018

Website: www.union-ic.com