

## Low Capacitance Quad Line ESD Protection Diode Array

### SM05 SOT23-3

#### General Description

The SM05 of transient voltage suppressors (TVS) are designed to protect components which are connected to data and transmission lines from voltage surges caused by electrostatic discharge (ESD). TVS diodes are characterized by their high surge capability, low operating and clamping voltages, and fast response time. This makes them ideal for use as board level protection of sensitive semiconductor components. The dual-junction common-anode design allows the user to protect one bidirectional data line or two unidirectional lines. The low profile SOT23 package allows flexibility in the design of “crowded” circuit boards. The SM05 will meet the surge requirements of IEC 61000-4-2 (Formerly IEC801-2), Level 4, “Human Body Model” for air and contact discharge.

#### Applications

- Cellular Handsets and Accessories
- Portable Electronics
- Industrial Controls
- Set-Top Box
- Servers, Notebook and Desktop PC

#### Features

- Transient Protection for Data & Power Lines to IEC 61000-4-2 (ESD)  $\pm 15\text{kV}$  (Air),  $\pm 8\text{kV}$  (Contact)
- Protects One Bidirectional Line or Two Unidirectional Lines
- Working Voltages: 5V
- Low Clamping Voltage
- Solid-State Silicon Avalanche Technology

#### Pin Configurations

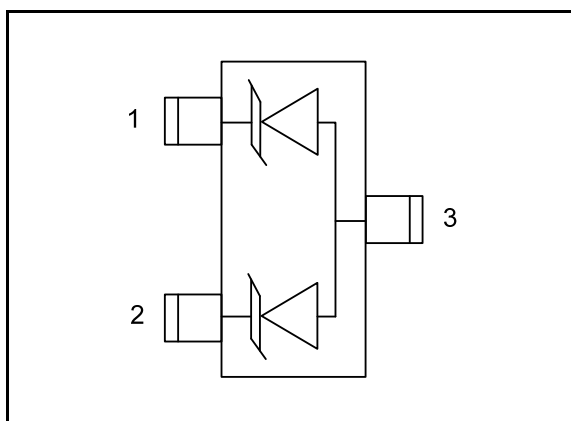

#### Top View

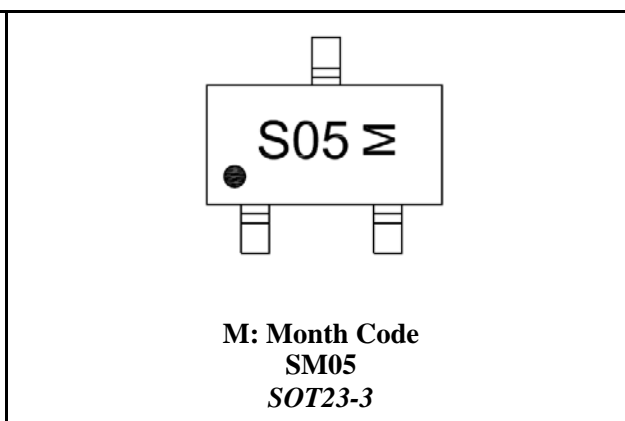

**Ordering Information**

Part Number	Working Voltage	Packaging Type	Channel	Marking Code	Shipping Qty
SM05	5.0V	SOT23-3	2	S05	3000pcs/7Inch Tape & Reel

**Absolute Maximum Ratings**

Rating	Symbol	Value	Unit
Peak Pulse Power ( $t_p=8/20\mu s$ )	$P_{PK}$	300	Watts
Thermal Resistance, Junction to Ambient	$\theta_{JA}$	325	$^{\circ}C/W$
Lead Soldering Temperature	$T_L$	260 (10 sec.)	$^{\circ}C$
Operating Temperature	$T_J$	-55 to +125	$^{\circ}C$
Storage Temperature	$T_{STG}$	-55 to +125	$^{\circ}C$

**Electrical Characteristics**

Parameter	Symbol	Conditions	Min	Typ	Max	Unit
Reverse Stand-Off Voltage	$V_{RWM}$				5	V
Reverse Breakdown Voltage	$V_{BR}$	$I_T=1mA$	6	6.8	7.2	V
Reverse Leakage Current	$I_R$	$V_{RWM}=5V, T=25^{\circ}C$			0.1	$\mu A$
Clamping Voltage	$V_C$	$I_{PP}=5A, t_p=8/20\mu s$			9.8	V
		$I_{PP}=17A, t_p=8/20\mu s$			17.6	
Peak Pulse Current	$I_{PP}$	$t_p=8/20\mu s$			17	A
Junction Capacitance	$C_J$	Pin 1 to 2 $V_R=0V,$ $f=1MHz$		25		pF
Junction Capacitance	$C_J$	Pin 1 to 3 and Pin 2 to 3 $V_R=0V, f=1MHz$		50		pF
Reverse Dynamic Resistance	$R_{dyn,rev}$	$I_{PP}>2A$		0.55		$\Omega$
Forward Dynamic Resistance	$R_{dyn,fwd}$			0.35		

## Typical Operating Characteristics

### Non-Repetitive Peak Pulse Power vs. Pulse Time

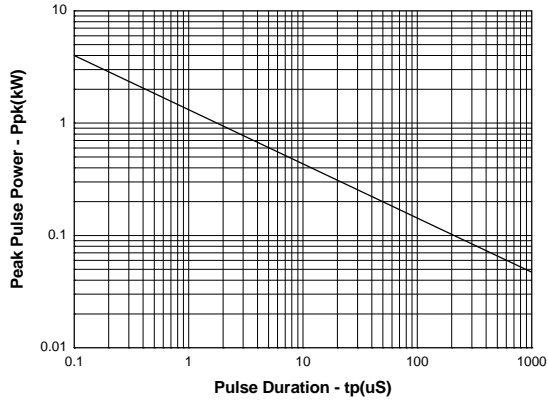

### Clamping Voltage vs. Peak Pulse Current

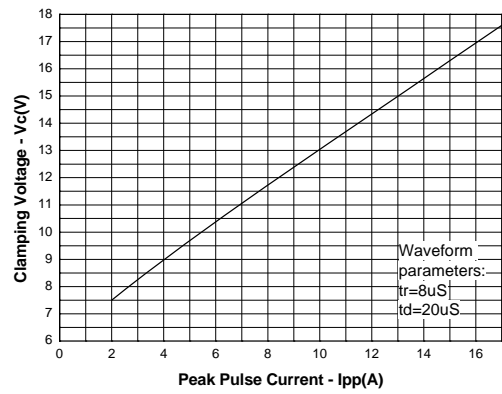

### ESD Pulse Waveform (Per IEC 61000-4-2)

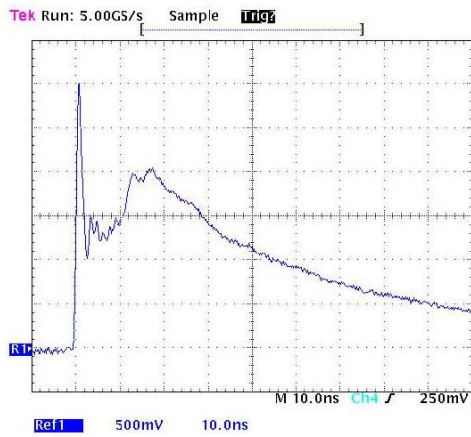

### IEC 61000-4-2 Discharge Parameters

Level	First Peak Current (A)	Peak Current at 30 ns (A)	Peak Current at 60 ns (A)	Test Voltage (Contact Discharge) (kV)	Test Voltage (Air Discharge) (kV)
1	7.5	4	8	2	2
2	15	8	4	4	4
3	22.5	12	6	6	8
4	30	16	8	8	15

## Typical Operating Circuits

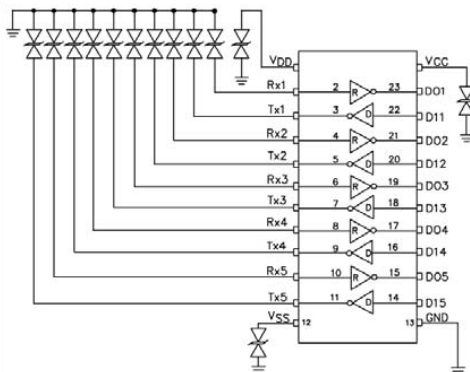

## Detailed Description

### Device Connection Options

The SM05 is designed to protect one bidirectional or two unidirectional data or I/O lines operating at 5 volts. Connection options are as follows: Bidirectional: Pin 1 is connected to the data line and pin 2 is connected to ground (Since the device is symmetrical, these connections may be reversed). The ground connection should be made directly to a ground plane. The path length should be kept as short as possible to minimize parasitic inductance. Pin 3 is not connected. Unidirectional: Data lines are connected to pin 1 and pin 2. Pin 3 is connected to ground. For best results, this pin should be connected directly to a ground plane on the board. The path length should be kept as short as possible to minimize parasitic inductance.

### Circuit Board Layout Recommendations for Suppression of ESD

Good circuit board layout is critical for the suppression of fast rise-time transients such as ESD. The following guidelines are recommended (Refer to application note SI99-01 for more detailed information): Place the TVS near the input terminals or connectors to restrict transient coupling. Minimize the path length between the TVS and the protected line. Minimize all conductive loops including power and ground loops. The ESD transient return path to ground should be kept as short as possible. Never run critical signals near board edges. Use ground planes whenever possible.

### Matte Tin Lead Finish

Matte tin has become the industry standard lead-free replacement for SnPb lead finishes. A matte tin finish is composed of 100% tin solder with large grains. Since the solder volume on the leads is small compared to the solder paste volume that is placed on the land pattern of the PCB, the reflow profile will be determined by the requirements of the solder paste. Therefore, these devices are compatible with both lead-free and SnPb assembly techniques. In addition, unlike other lead-free compositions, matte tin does not have any added alloys that can cause degradation of the solder joint.

## Package Information

### SM05: SOT23-3

#### Outline Drawing

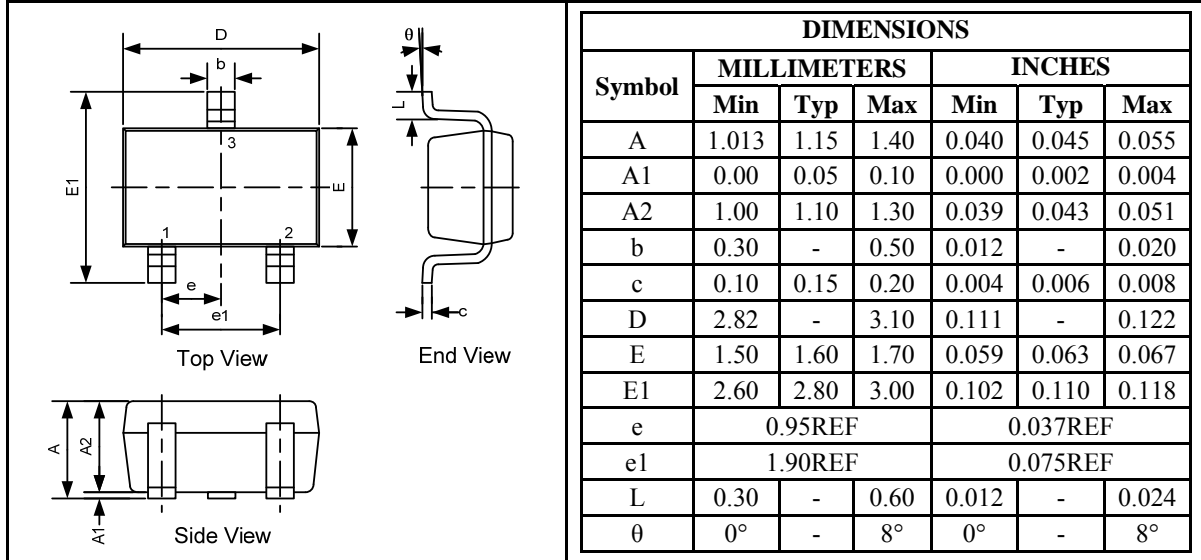

#### Land Pattern

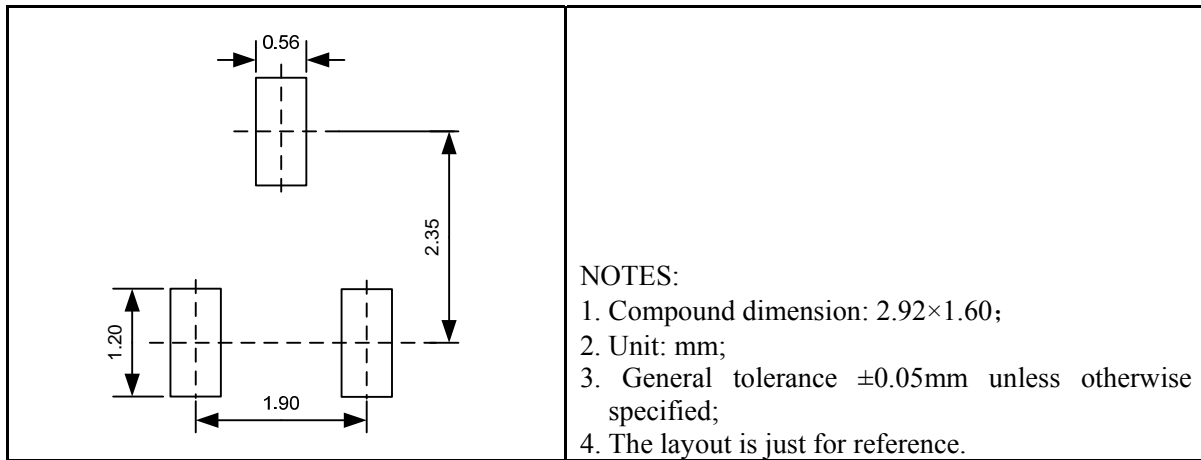

#### Tape and Reel Orientation

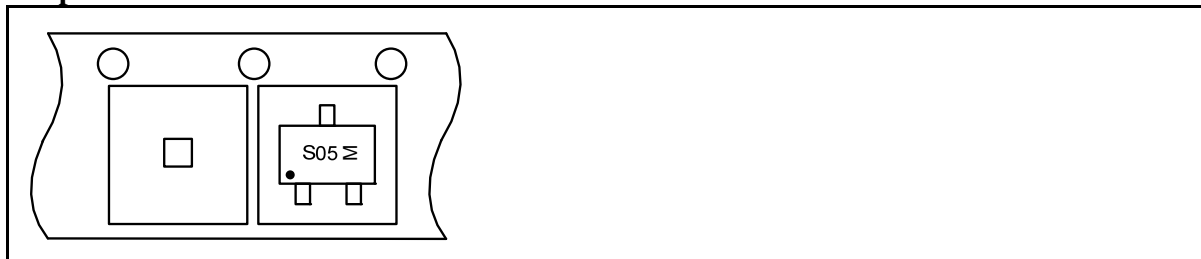

---

## **GREEN COMPLIANCE**

Union Semiconductor is committed to environmental excellence in all aspects of its operations including meeting or exceeding regulatory requirements with respect to the use of hazardous substances. Numerous successful programs have been implemented to reduce the use of hazardous substances and/or emissions.

All Union components are compliant with the RoHS directive, which helps to support customers in their compliance with environmental directives. For more green compliance information, please visit:

[http://www.union-ic.com/index.aspx?cat\\_code=RoHSDeclaration](http://www.union-ic.com/index.aspx?cat_code=RoHSDeclaration)

## **IMPORTANT NOTICE**

The information in this document has been carefully reviewed and is believed to be accurate. Nonetheless, this document is subject to change without notice. Union assumes no responsibility for any inaccuracies that may be contained in this document, and makes no commitment to update or to keep current the contained information, or to notify a person or organization of any update. Union reserves the right to make changes, at any time, in order to improve reliability, function or design and to attempt to supply the best product possible.



Union Semiconductor, Inc

Add: Unit 606, No.570 Shengxia Road, Shanghai 201210

Tel: 021-51093966

Fax: 021-51026018

Website: [www.union-ic.com](http://www.union-ic.com)